

Line **ITAP**



 **IMBIL**®

Pumping Solutions



INTRODUCTION

This catalog describes all pump models of the ITAP line manufactured by IMBIL and includes technical information on construction, applications, design, special features and attributes of the line, in addition to dimensional drawings and characteristic curves of each model.

ADDITIONAL INFORMATION

If you have any questions regarding our products and services, IMBIL and its representatives are always at your service to provide you with any further information and technical assistance. Use our consumer hotline DDG 0800 148500.

NOTES

We reserve the right to make any modifications that we deem necessary or required to our products at any time without entailing any obligations of any nature.

APPLICATIONS

Sugar mills, distilleries, chemical and petrochemical industries, pulp and paper plants, irrigation, basic sanitation, fire fighting systems, refrigeration, air conditioning, civil construction, farming, textile industries and a vast number of other industrial and agri-industrial applications.

APLICAÇÕES

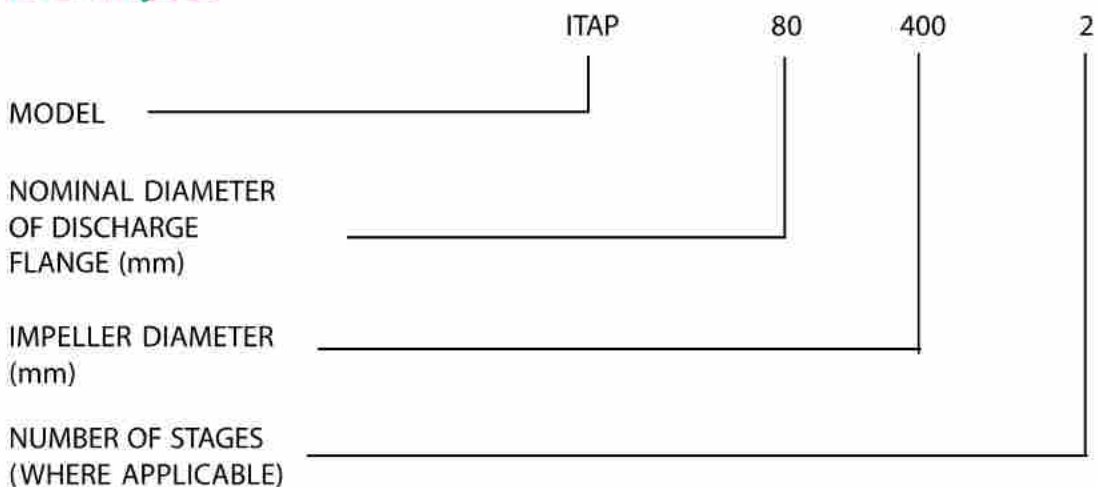



MAXIMUM PERIPHERAL SPEED

When specifying the product, the rotation of the pump and the impeller maximum peripheral speed must be observed, according to the construction material:

Material	Maximum Speed
Cast Iron GG20	40 [m/s]
Nodular Iron GGG40	60 [m/s]
Bronze SAE 40	60 [m/s]
Stainless Steel – CF8M (ASTM A 743)	80 [m/s]

DRIVER

Performed by means of elastic coupling, electric motor, turbine, internal combustion engine, speed reducer or by belt and pulley transmission.

POWER RESERVE

Power Required by Pump (HP)	Driver power reserve
Up to 2	20%
Up to 20	15%
Over 20	10%

SINGLE-STAGE PUMPS

Cross-section view, parts and components

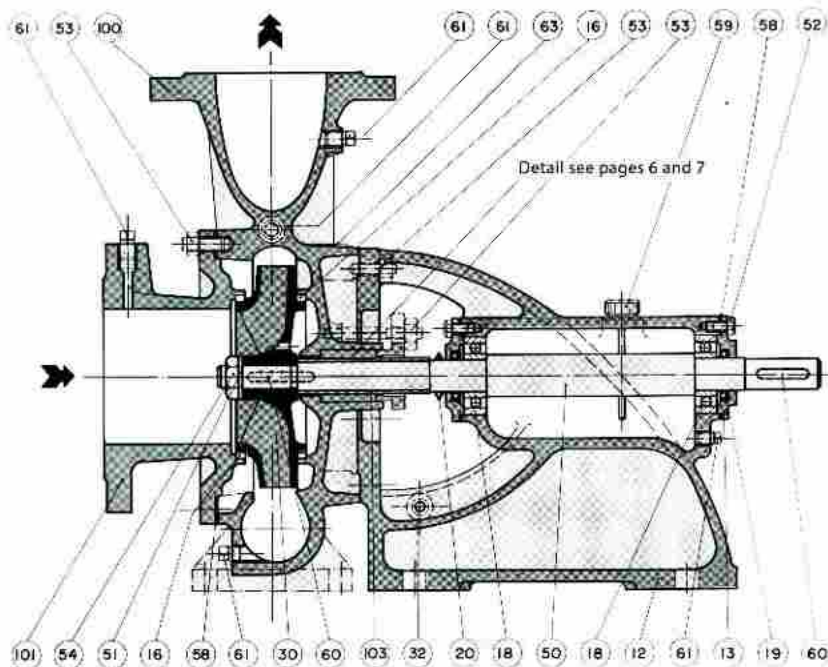

Component	Denomination	Material	Notes
12	Bearing housing	GG-20	
13	Bearing housing cover	GG-20	
16	Wear ring	GG-20	
20	Centrifuge ring	Nitrilic Rubber	
30	Impeller	GG-20	
32	Dripping outlet		
50	Shaft	SAE 4140	
51	Shaft end locking washer	SAE 1020	
52	Hex screw	SAE 1020	
53	Hex tap bolt and nuts	SAE 1020	
54	Impeller nut	SAE 1020	
58	Plain joints	K. oilit	
59	Oil level	Nylon	
60	Key	SAE 1045	
61	Plugs	F. maleável galv.	
63	Small plate	Alumínio	
100	Spiral Piece	GG-20	
101	Suction cover	GG-20	Not used for models 32.120, 32.160, 40.120 and 40.160.
103	Shaft sleeve	SAE 1020	For bearing housings n° 4 and 5.

Component 18 - Bearings

Bearing housing	1	2	3	4	5	*5	
Quantity	2	2	2	2	2	1+1	
Material	6.304/C3	6.305/C3	6.306/C3	6.409/C3	6.411/C3	6.411/C3-6.313/C3	*For models 250.290 and 300.350

Component 19 - Retainers (Material - Nitrilic rubber)

Bearing housing	1	2	3	4	5	*5
Quantity	2	2	2	2	2	2
Dimensions	20x35x7	25x42,9x9,5	30x50x12	45x62x10	55x80x13	55x80x13



TWO-STAGE PUMPS

Cross-section view, parts and components

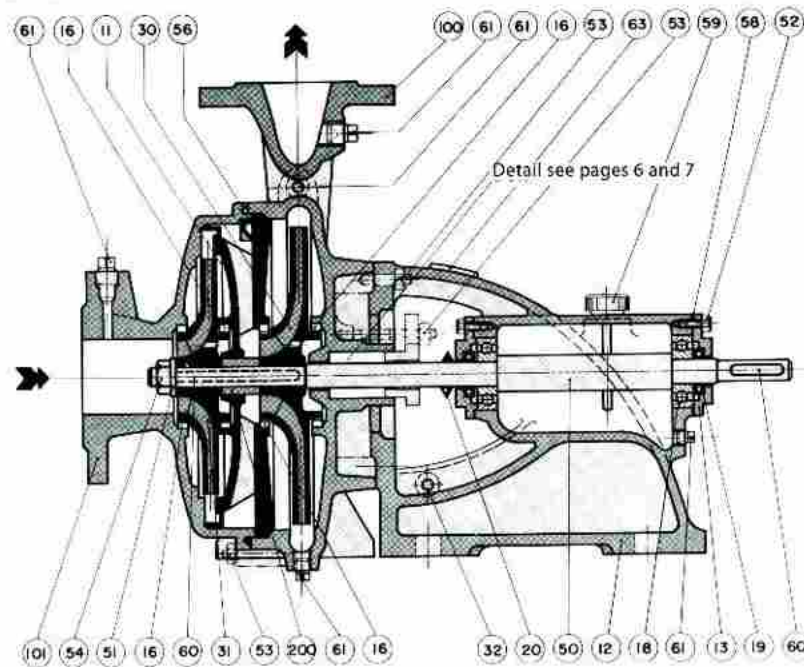

Component	Denomination	Material	Notes
11	Diffusers	GG-20	1 part
12	Bearing housing	GG-20	
13	Bearing housing cover	GG-20	
16	Wear ring	GG-20	
20	Centrifuge ring	Nitrilic Rubber	
30	Impeller	GG-20	
31	Impeller (stage)	GG-20	
32	Dripping outlet		
50	Shaft	SAE 4140	
51	Shaft end locking washer	SAE 1020	
52	Hex screw	SAE 1020	
53	Hex tap bolt and nuts	SAE 1020	
54	Impeller nut	SAE 1020	
56	O Ring	Nitrilic Rubber	
58	Plain joints	K.oilit	
59	Oil level	Nylon	
60	Key	SAE 1045	
61	Plugs	F. maleável galv.	
63	Small plate	Aluminio	
100	Spiral piece	GG-20	
101	Suction cover	GG-20	Not used for models: 32.120, 32.160, 40.120 and 40.160.
200	Separating sleeve	GG-20	For bearing housings n° 4 and 5

Component 18 - Bearings

Bearing Housing	1	2	3	4	5	*5
Quantity	2	2	2	2	2	1+1
Material	6.304/C3	6.305/C3	6.306/C3	6.409/C3	6.411/C3	6.411/C3-6.313/C3 *For models 250.290 and 300.350

Component 19 - Retainers (Material - Nitrilic Rubber)

Bearing Housing	1	2	3	4	5	*5
Quantity	2	2	2	2	2	2
Dimensions	20x35x7	25x42,9x9,5	30x50x12	45x62x12	55x80x13	55x80x13

THREE-STAGE PUMPS

Cross-section view, parts and components

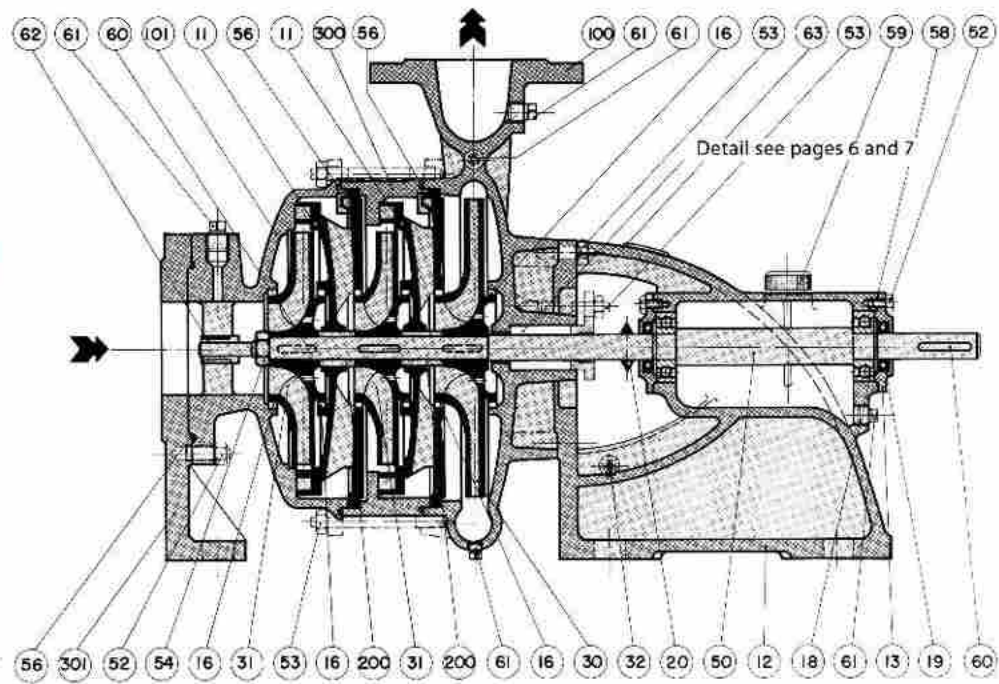

Component	Denomination	Material	Notes
11	Diffusers	GG-20	2 part
12	Bearing housing	GG-20	
13	Bearing housing cover	GG-20	
16	Wear ring	GG-20	
20	Centrifuge ring	Nitrilic Rubber	
30	Impeller	GG-20	
31	Impeller (stage)	GG-20	
32	Dripping outlet		
50	Shaft	SAE 4140	
52	Hex screw	SAE 1020	
53	Hex tap bolt and nuts	SAE 1020	
54	Impeller nut	SAE 1020	
56	O'Ring	Nitrilica Rubber	
58	Plain joints	K. oilit	
59	Oil level	Nylon	
60	Key	SAE 1045	
61	Plugs	F. maleável galv.	
62	Suction cover sleeve	SAE 40	For models 50.330/3, 65.330/3 and 80.400/3
63	Small plate	Aluminio	
100	Spiral piece	GG-20	
101	Suction cover	GG-20	Not used for models 32.120, 32.160, 32.200, 40.120 and 40.160.
200	Separating sleeve	GG-20	
300	Stage piece	GG-20	
301	Pump casing feet	GG-20	Only for model 80.400/3

Component 18 - Bearings

Bearing Housing	1	2	3	4	5	*5
Quantity	2	2	2	2	2	1+1
Material	6.304/C3	6.305/C3	6.306/C3	6.409/C3	6.411/C3	6.411/C3-6.313/C3

*For models 250.290 and 300.350

Component 19 - Retainers (Material - Nitrilic Rubber)

Bearing Housing	1	2	3	4	5	*5
Quantity	2	2	2	2	2	2
Dimensions	20x35x7	25x42,9x9,5	30x50x12	45x62x12	55x80x13	55x80x13



ROTATION, SEALING AND REFRIGERATION

Variation coefficient of pump rotation

		Required rotation - rpm											
		1500	1600	1800	1900	2000	2100	2200	2300	2400	2500	2600	3000
Basic curve rotations at 1750 rpm	Q (x)	0,86	0,91	1,03	1,09	1,14	1,20	1,26	1,31	1,37	1,43	1,48	1,71
	H (x)	0,73	0,83	1,06	1,18	1,30	1,44	1,58	1,73	1,88	2,04	2,20	2,94
	N (x)	0,63	0,76	1,09	1,28	1,49	1,73	1,98	2,27	2,58	2,91	3,28	5,04
Basic curve rotations at 3500 rpm	Q (x)	0,43	0,43	0,51	0,54	0,57	0,60	0,63	0,66	0,68	0,71	0,74	0,86
	H (x)	0,18	0,21	0,26	0,29	0,32	0,36	0,39	0,43	0,47	0,51	0,55	0,73
	N (x)	0,08	0,095	0,136	0,160	0,186	0,216	0,25	0,28	0,32	0,36	0,41	0,63

Q = volumetric flow (m³/h) H= Head (m) N = Power (CV)

SEALING AND REFRIGERATION SYSTEMS

Standard execution

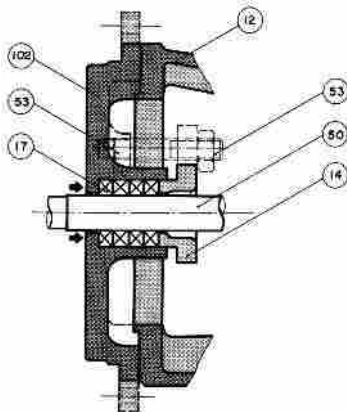

Bearing Housing 1

Execution with refrigeration

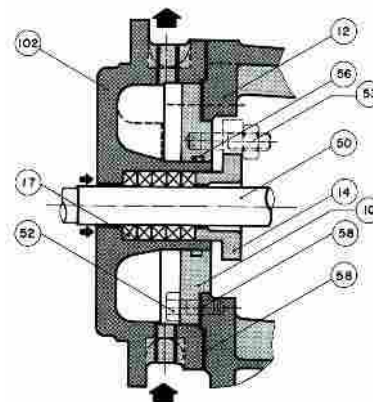

Pumps of Bearing Housing 1 mounted on Bearing Housing 2

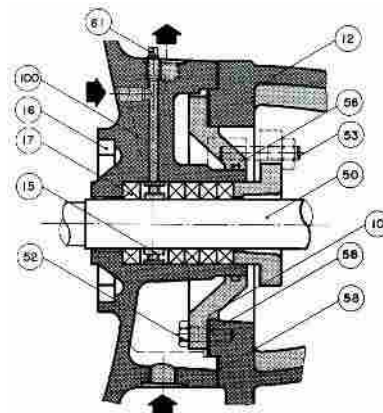
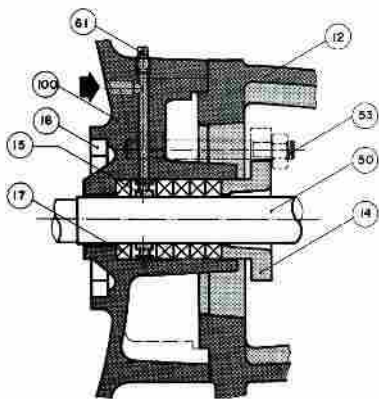

Bearing Housings 2, 3, 4 and 5: internal refrigeration by clear liquids and negative suction pressure

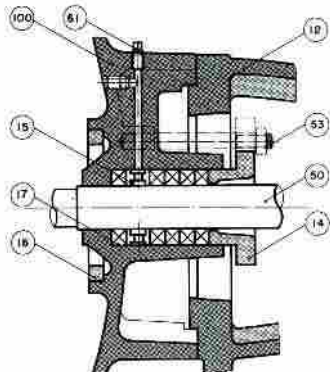

Bearing housings 2, 3, 4 and 5: external refrigeration with internal outflow.

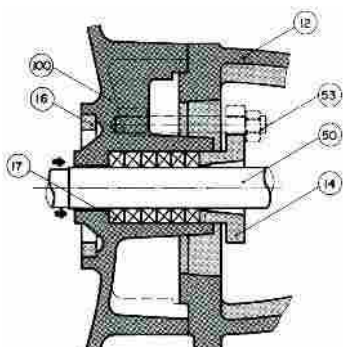

Bearing housings 2, 3, 4 and 5: clear liquids with positive suction pressure.

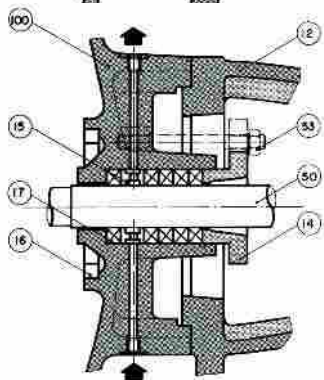

Bearing housings 2, 3, 4 and 5: external refrigeration with external outflow.

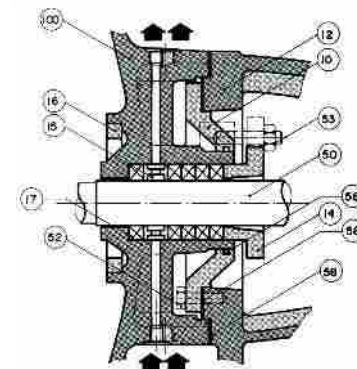
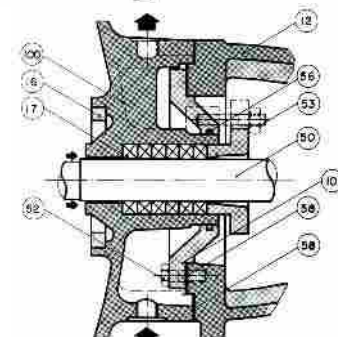
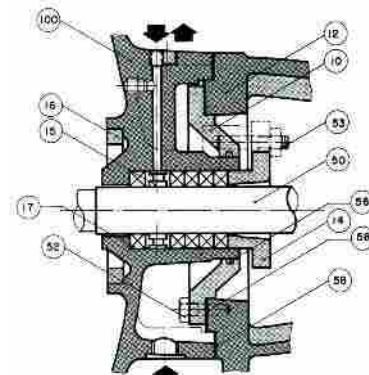

PARTS AND COMPONENTS OF THE SEALING AND REFRIGERATION SYSTEMS

Component	Denomination	Material	Notes
10	Refrigeration chamber cover	GG-40	For models with refrigeration
12	Bearing Housing	GG-20	
14	Stuffing box packing gland	GG-20	
15	Lantern ring	GG-20	
16	Wear ring	GG-20	
17	Packing	Amianto Graf.	
50	Shaft	SAE 4140	
52	Hex screw	SAE 1020	
53	Hex tap bolt and nuts	SAE 1020	
56	O'Ring	Nitrilic Rubber	
58	Plain joints	K. oilit	
61	Plugs	F. maleável galv.	
100	Spiral piece	GG-20	
102	Pressure cover	GG-20	For models 32.120, 32.160, 32.200, 40.120 and 40.160.



BEARING HOUSING 1

Basic Dimensions

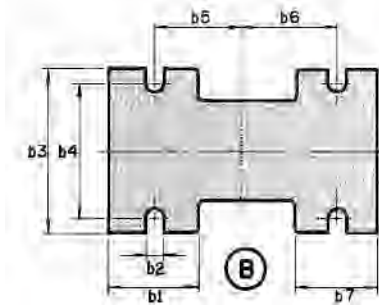
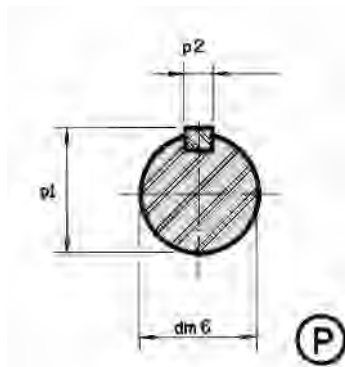
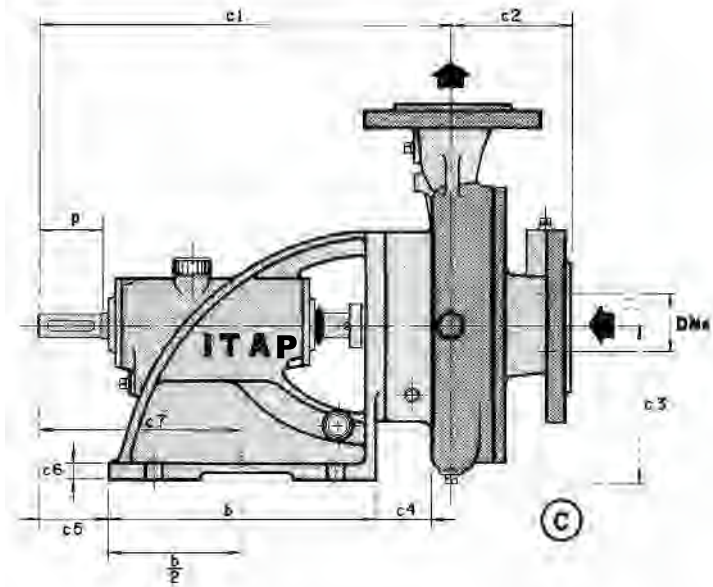
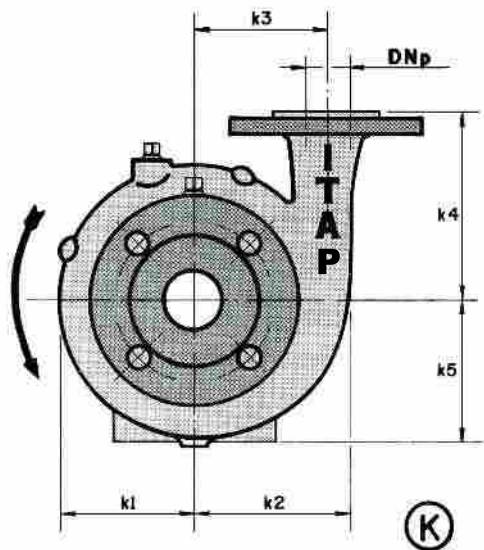

Pump Measurements in mm

Model	Housing	DN		B						C							K					P			∅ dm6					
		DNs	DNp	b	b ₁	b ₂	b ₃	b ₄	b ₅	b ₆	c ₁	c ₂	c ₃	c ₄	c ₅	c ₆	c ₇	k ₁	k ₂	k ₃	k ₄	k ₅	p	p ₁		p ₂				
32.120 32.160	1	40	32	190	55	14	115	90	67	69	321	75	87	52	60	12	155	81	96	80	116	97	113	97	135	100	40	20,2	6	18
40.120 40.160	1	50	40	190	55	14	115	90	67	69	315	75	107	44	60	12	155	88	108	85	120	105	110	94	130	100	40	20,2	6	18
50.120 50.160	1	65	50	190	55	14	115	90	67	69	320	100	117	44	60	12	155	96	123	95	130	115	130	105	150	100	40	20,2	6	18
65.120 65.160	1	80	65	190	55	14	115	90	67	69	320	110	143	38	60	12	155	121	142	105	140	124	148	117	160	100	40	20,2	6	18

BEARING HOUSINGS 2 and 3

Basic Dimensions

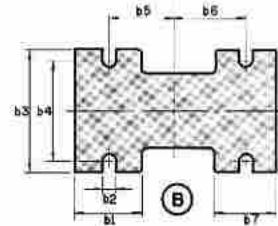
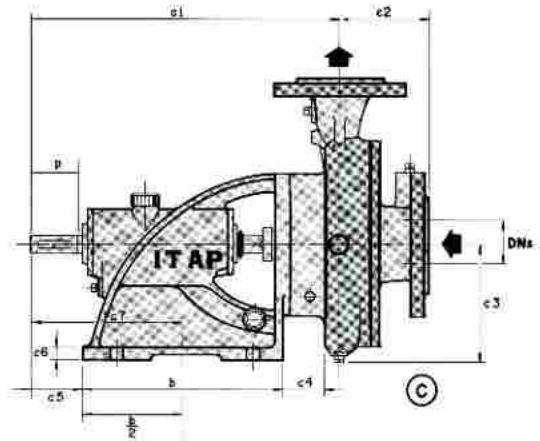
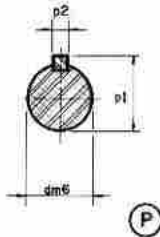
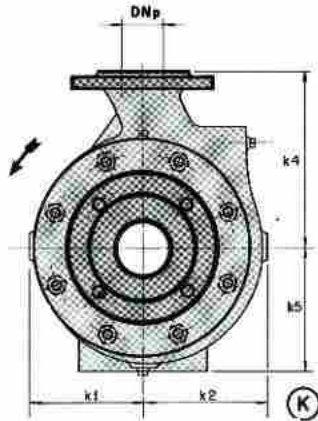

Pump Measurements in mm																										
Model	Housing	DN		B									C				K				P			dm6		
		DNs	DNp	b	b ₁	b ₂	b ₃	b ₄	b ₅	b ₆	b ₇	c ₁	c ₂	c ₃	c ₄	c ₅	c ₆	c ₇	k ₁	k ₂	k ₄	k ₅	p		p ₁	p ₂
32.200	2	40	32	280	95	19	170	140	90	100	85	445	90	138	25	76	18	216	140	140	175	160	72	26,9	8	24
40.200 40.260 40.330/2	2	50	40	280	95	19	170	140	90	100	85	425	110	147	53	76	18	216	135	138	200	160	65	26,9	8	24
50.200 50.260 50.330/2 50.330/3	2	65	50	280	95	19	170	140	90	100	85	425	110	156	47	76	18	216	138	150	225	160	65	26,9	8	24
65.200 65.260 65.330/2 65.330/3	2	80	65	280	95	19	170	140	90	100	85	430	125	162	49	76	18	216	142	160	225	160	65	26,9	8	24
80.160 80.200	2 2	100	80	280	95	19	170	140	90	100	85	435	130	145	43	76	18	216	135	165	225	160	65	26,9	8	24
80.260 80.330 80.400/2 80.400/3	3 3 3 3	100	80	335	100	23	205	175	118	122	95	479	125	190	45	69	20	237	180	203	300	200	65	30,9	8	28
100.160	2	125	100	280	95	19	170	140	90	100	85	435	130	170	34	76	18	216	154	195	275	160	65	26,9	8	24
100.200 100.260 100.330	3 3 3	125	100	335	100	23	205	175	118	122	95	484	155	178	39	69	20	237	163	200	275	200	65	30,9	8	28
125.200 125.260	3	150	125	335	100	23	205	175	118	122	95	489	150	202	33	69	20	237	183	227	300	200	65	30,9	8	28
150.200	3	150	150	335	100	23	205	175	118	122	95	482	191	232	15	69	20	237	194	262	350	200	65	30,9	8	28

Models with /2 = 2 stages and /3 = 3 stages



BEARING HOUSINGS 4 AND 5

Basic Dimensions

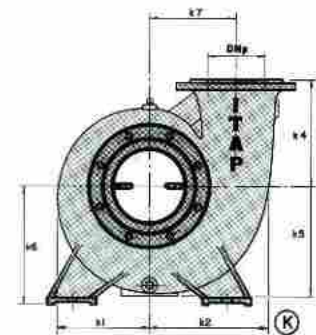
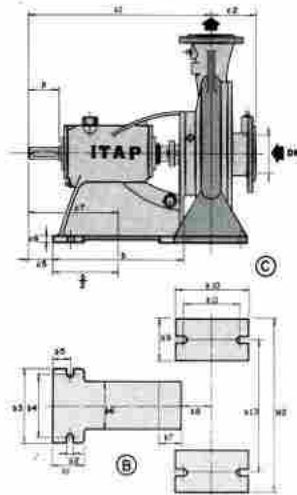
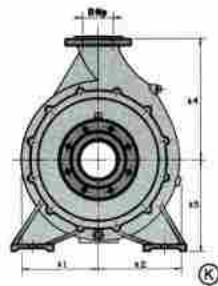

Volute case for models
200.230, 250.290 and 300.350

Pump Measurements in mm

Model	Housing	DN		B													dm6	
		DNs	DNp	b	b ₁	b ₂	b ₃	b ₄	b ₅	b ₆	b ₇	b ₈	b ₉	b ₁₀	b ₁₁	b ₁₂		b ₁₃
100.400 100.500/2	4	125	100	445	105	22	250	210	60	160	80	96	140	250	190	580	440	42
125.330 125.400 125.500/2	4	150	125	445	105	22	250	210	60	160	80	101 91 91	140	250	190	580	440	42
150.260 150.330 150.400 150.500	4 4 5 5	200 200	150 150	445 650	105 150	22 26	250 380	210 335	60 85	160 200	80 120	101 96 128 128	140	250	190	580 700	440 560	42 50
200.230 200.330 200.400	4 5 5	200 250	200 200	445 650	105 150	24 28	250 380	210 335	60 85	160 200	80 120	107 133 138	140	250	190	580 700	440 560	42 50
250.290 250.330 250.400	5	250 300 300	250	650	150	28	380	335	85	200	120	138 111 133	140 140	250	190	800 700 800	660 560 660	50
300.350	5	300	300	650	150	28	380	335	85	200	120	148	160	320	260	840	680	50

Model	Housing	DN		C					K					P			dm6	
		DNs	DNp	c ₁	c ₂	c ₃	c ₄	c ₅	k ₁	k ₂	k ₃	k ₄	k ₅	k ₆	k ₇	p		p ₁
100.400 100.500/2	4	125	100	624	155 230	83	22	306	255	275	400	300	300	-	105	45,1	12	42
125.330 125.400 125.500/2	4	150	125	629 619 619	150 160 247	83	22	306	230 267 267	266 298 298	375 475 475	300	300	-	105	45,1	12	42
150.260 150.330 150.400 150.500	4 4 5 5	200 200	150 150	629 624 870 870	170 170 160 170	83 83	22 25	306 417	222 245 285 323	283 300 325 363	400 425 425 525	300 300	300	-	105 135	45,1 53,5	12 14	42 50
200.230 200.330 200.400	4 5 5	200 250	200 200	635 875 880	250 175 180	83 92	22 25	306 417	264 277 308	335 353 372	300 475 525	300 400	330 400	244	105 135	45,1 53,5	12 14	42 50
250.290 250.330 250.400	5	250 300 300	250	880 853 875	220 245 180	92 92 92	25	417	340 295 330	435 398 410	350 525 600	400 400	292 -	-	135	53,5	14	50
300.350	5	300	300	890	300	92	25	417	405	520	450	400	520	352	135	53,5	14	50

Models with /2 = 2 stages



FLANGES

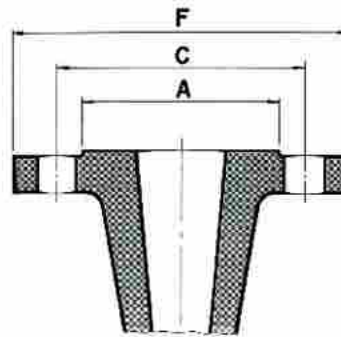

Models	Mounting	Suction flange (mm)						Pressure flange (mm)					
		EN 1092-2 Standard	DN	F ø flange	C ø center holes	A ø flange ring	Screws Number of holes	EN 1092-2 Standard	DNp	F ø flange	C ø center holes	A ø flange ring	Screws Number of holes
32.120 32.160	1	PN16	40	150	110	88	4 18	PN16	32	140	100	78	4 18
40.120 40.160	1	PN16	50	165	125	102	4 18	PN16	40	150	110	88	4 18
50.120 50.160	1	PN16	65	185	145	122	4 18	PN16	50	165	125	102	4 18
65.120 65.160	1	PN16	80	200	160	138	8 18	PN16	65	185	145	122	4 18
32.200	2	PN16	40	150	110	88	4 18	PN16	32	140	100	78	4 18
40.200 40.260 40.330	2	PN16	50	165	125	102	4 18	PN16	40	150	110	88	4 18
50.200 50.260 50.330/2	2	PN16	65	185	145	122	4 18	PN16	50	165	125	102	4 18
65.200 65.260 65.330/2	2	PN16	80	200	160	138	8 18	PN16	65	185	145	122	4 18
80.160 80.200 80.260 80.330 80.400/2	2 2 3 3 3	PN16	100	220	180	158	8 18	PN16	80	200	160	138	8 18
100.160 100.200 100.260 100.330	2 3 3 3	PN16	125	250	210	188	8 18	PN16	100	220	180	158	8 18
125.200 125.260	3	PN16	150	285	240	212	8 22	PN16	125	250	210	188	8 18
150.200	3	PN16	150	285	240	212	8 22	PN16	150	285	240	212	8 22
100.400 100.500/2	4	PN16	125	250	210	188	8 18	PN16	100	220	180	158	8 18
125.330 125.400 125.500/2	4	PN16	150	285	240	212	8 22	PN16	125	250	210	188	8 18
150.260 150.330 150.400 150.500	4 4 5 5	PN10	200	340	295	268	8 22	PN16	150	285	240	212	8 22
200.230 200.330 200.400	4 5 5	PN10	200	340	295	268	8 22	PN10	200	340	295	268	8 22
250.290 250.330 250.400	5	PN10	250	395	350	320	12 22	PN10	250	395	350	320	12 22
300.350	5	PN10	300	445	400	370	12 22	PN10	300	445	400	370	12 22