

SERIES

INI



 **IMBIL**[®]
Pumping Solutions

INTRODUCTION

In this catalogue the entire range of pump models from the series INI/INI-bloc produced by our company are described.

It contains technical information about construction, and characteristic curves from each model. Imbil and its DISTRIBUTORS will always be at your disposal to supply for additional information and to offer technical assistance.

NOTES

- We reserve the right to perform modifications in our products whenever necessary and this shall not incur in obligations of any type.
- The illustrations contained in this catalogue are indicative and in case there are any questions about their interpretation you must consult the IMBIL DISTRIBUTOR.

APPLICATION INI

Pumping of liquids in wastewater, irrigation, chemical and petrochemical industries, sugarmills, distilleries paper and pulp industries, raw sewage, sugar bagasse, circulation of thermal oil, condensed liquids etc.

CONSTRUCTION

Constructed dimensionally according to the norms **DIN 24 256/ ISO 2858**, and mechanically according to the norm **ANSI B73.1**.

Horizontal shaft pumps, single stage, horizontal suction and vertical discharge, with "**BACK PULL-OUT**" construction, allowing the disassembly from the back for eventual maintenance and repair, without affecting the alignment and fixation of the piping.

Spiral housing, casted in one single piece, with the fixation supports incorporated.

The sealing between the impeller and the housing is made by a replaceable wear ring, facilitating the pump maintenance.

The Shaft Sealing is ensured by a gasket in the standard execution, or optionally by a mechanical seal.

The **Shaft** has a protective bushing in the stuffing box packing region, without contact with the pumped liquid.

The **Impeller** is closed, single flow radial and has **axial thrust balance** through the relief holes, except in the models 32-125 and 32-160.

Depending on the temperature of the pumped liquid, the pumps may be supplied with a cooling chamber.

APLICACION INI-BLOC

The pumps INI-Bloc are indicated for the pumping of clean or cloudy liquids and can be used in building and air conditioning facilities, in cooling services, in the condensed liquids circulation, irrigation, farming, public services, industrial water supply etc.

CONSTRUCTION TECHNIQUES

Horizontal shaft pumps, single stage, horizontal suction and vertical discharge, with "BACK PULL-OUT" construction, allowing the disassembly from the back for eventual maintenance and repair, without affecting the alignment and fixation of the piping.

Housing

Volute, caste in one single piece, with the fixation supports incorporated. The discharge and suction are flanged (ANSI B16.1 FF/ B16.5 RF/EN 1092-2).

Note: some models can be supplied with threaded suction and discharge.

Impeller

The impeller is closed, single flow radial. The axial thrust balance is made through relief holes. The impeller is and keyed directly on the engine.

Pressure cover / Junction part

All the pump sizes use the Pressure cover and some also use the Junction Part.

These parts have the function of coupling the Housing to the Engine flange, allowing a perfect alignment between them.

Sealing

Through Mechanical Seal, TYPE 21

Protective Bushing

Surrounds the motor axle in the sealing region, preventing the pumped liquid from getting in contact with the shaft.

Electric Motor

Is supplied with the pump.

Standardized with Flange and shaft Stub JM/ JP according with the norm NEMA.

Motor Characteristics:

Protection Degree: IP 55

Insulation: Class B (130° C) - NBR 7094

Service Factor: 1.15 (up to 50 HP) – 1.00 (above 50 HP)

Rotation: 3500/ 1750 RPM

Frequency: 60Hz

Note: when purchasing the pump kit (without the motor), please inform the motor manufacturer.



Range Coverage Chart

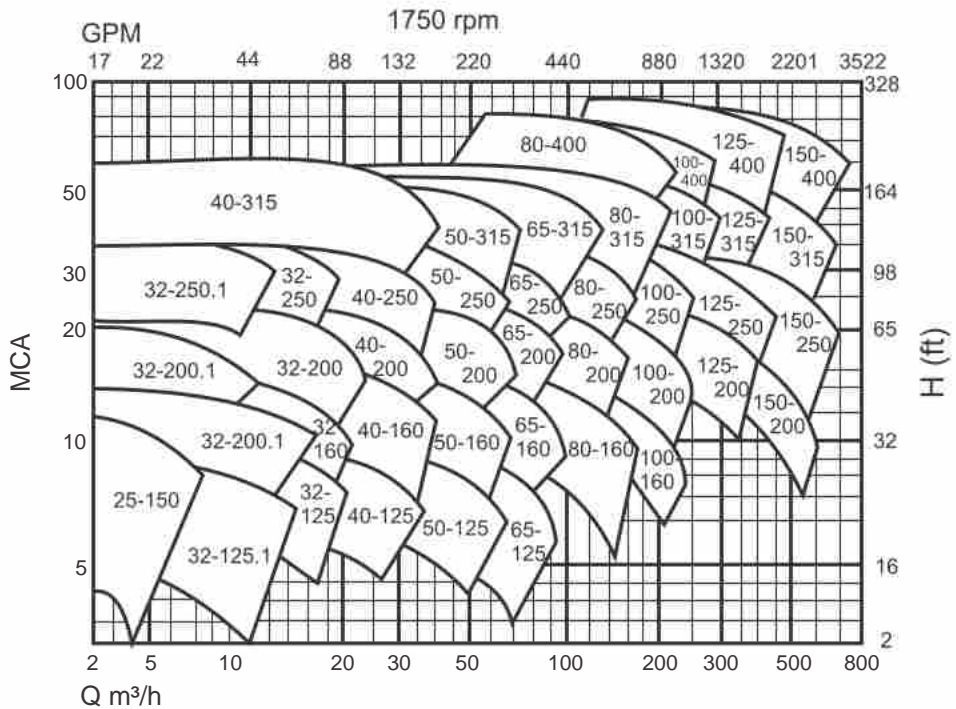
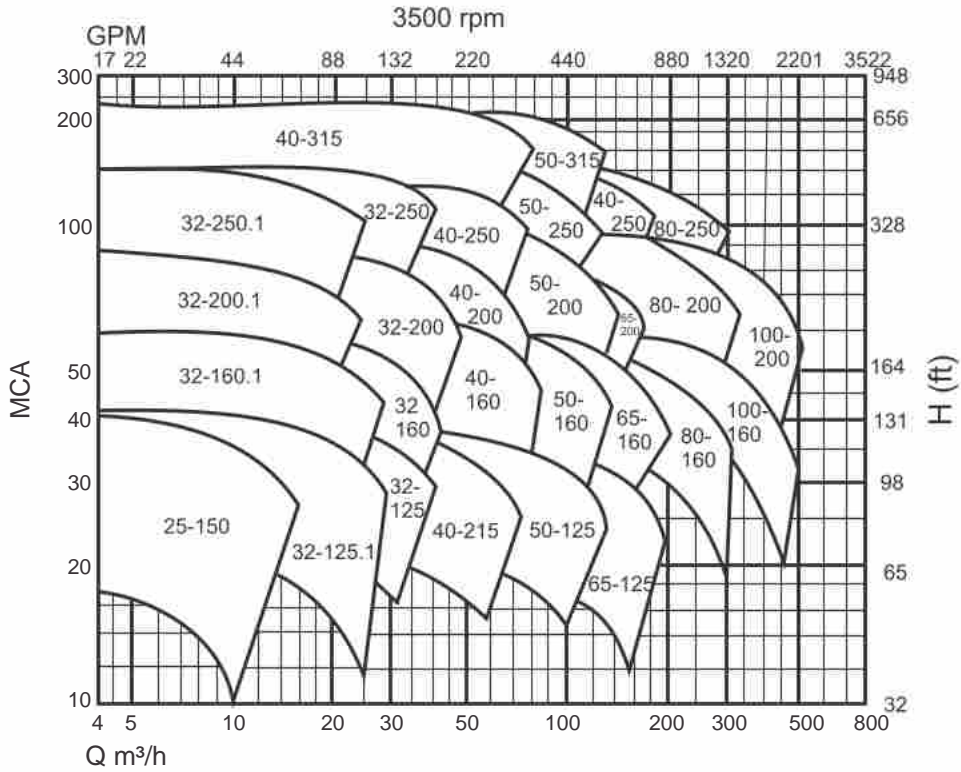



TECHNICAL DATA

- Suction Maximum Pressure (bar):

10 bar- Discharge Maximum Pressure according to models with refrigeration chamber (C°)

- Discharge Maximum Pressure according to the Temperature:

See Figures 1, 2, 3 and 4 (page 7). DP

DP = SP + DiffP (Q = 0)

DP = Discharge Pressure

SP = Suction Pressure

DiffP= Differential Pressure

- Minimum/maximum pressure for models with no cooling chamber (C°):

With packing = -50/ + 105 °C. With Mechanical Seal according to manufacturer recommendation.

With Mechanical Seal according to manufacturer recommendation.

- Minimum/Maximum Temperature for models with refrigeration chamber (C°)

With refrigeration chamber (C°):

With packing = see Figures 1 and 2 (pag 8); With Mechanical Seal according to manufacturer recommendation.

- Pressure of Hydrostatic Test (bar):

According to ANSI B 73.1

- Rotation direction:

Clockwise, as seen from the actuation side.

- Type of oil that should be used during lubrication:

Up to 1800 rpm - Castro Hyspin AWS 68.

Above 1800 rpm - Castrol Hyspin AWS 46.

The values indicate in the table below for cooling liquid flow are based in a ? of 15 °C. The maximum temperature at the cooling chamber outlet is 50 °C

Models	Unit	25-150	32-125.1	32-160.1	32-200.1	32-125	32-160	32-200	40-125	40-160	40-200	50-125	50-160	50-200	65-125	32-250.1	40-250	50-250	65-160	65-200	80-160	40-315	50-315	65-250	80-200	80-250	100-160	100-200	65-315	80-315	80-400	100-250	100-315	100-400	125-250	125-315	125-400	150-200	150-250	150-315	150-400		
Bearing Housing		130										140					140 R					150					160																
Impeller width	mm	6	7	5	6	9	5	6	12	12	9	20	16	11	25	6	8	8	12	17	31	9	9	13	23	19	36	32	13	18	13	27	23	17	37	30	25	59	48	39	33		
GD ³ rotating set with water	Kg.m ²	0,0216	0,0140	0,0224	0,0760	0,0140	0,0239	0,0785	0,0145	0,0334	0,0639	0,0190	0,0395	0,0749	0,0263	0,1800	0,1921	0,1879	0,1919	0,0520	0,0983	0,0640	0,4395	0,4801	0,2231	0,1569	0,2903	0,1039	0,1801	0,5121	0,5695	1,2787	0,3171	0,6101	1,3830	0,2231	0,4101	0,7739	1,6911	0,2917	0,4657	0,8681	1,8601
Weight in cast iron	Kg	28	34	34	42	37	45	45	38	38	48	40	41	47	49	68	67	73	73	70	60	90	103	107	89	93	105	106	125	132	161	131	143	178	135	157	156	192	182	245	280		
Maximum rotation	rpm	3500															1750																										
Refrigeration liquid volumetric flow according to pumping temperature	140 °C	1,2										2,2					3,1					3,7																					
	160 °C	1,5										2,7					3,3					4,5																					
	200 °C	2,2										3,3					4,4					4,7																					
	250 °C	3,0										4,0					5,6					7,3																					
	350 °C	4,0										4,9					7,0					8,0																					
Refrigeration fluid maximum pressure	bar	7																																									
Maximum / minimum volumetric flow		0,1 Qot/1,1 Qot															0,15 Qot/1,1 Qot																										
Flanges	Iron/ Bronze	Stander	ANSI B 16.1 125 Lb FF										250 Lb FF	125 Lb FF	250 Lb FF	B 16.1 125 Lb FF																											
		Opcional	—										125 Lb FF	250 Lb FF	125 Lb FF	B 16.1 205 Lb FF																											
	Steel	Stander	ANSI B 16.5 150 Lb RF																																								
		Opcional	—																																								
Bearings		6303 C3										6308 C3					6308 C3	6310 C3					6312 C3																				
P/N Maximum admissible	CV/rpm	0,0175										0,0330					0,0460					0,101					0,157																
P/N Maximum admissible for pumps with SAE 40 Impeller	CV/rpm	0,00707										0,01868					0,02420					0,03629					0,5757																
<input checked="" type="checkbox"/> Packing	mm	10																				12,5					12,5																

*125Lb FF **250Lb FF ***Bearing Pump Side: NU 308 EC/Bearing Driver Side: 7308(2x)

TECHNICAL DATA

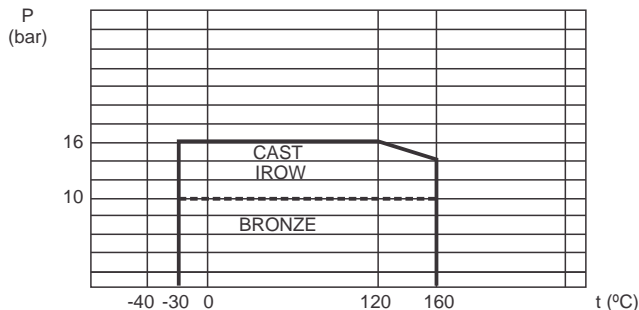

Fig. 1 – Maximum discharge pressure according to temperature.

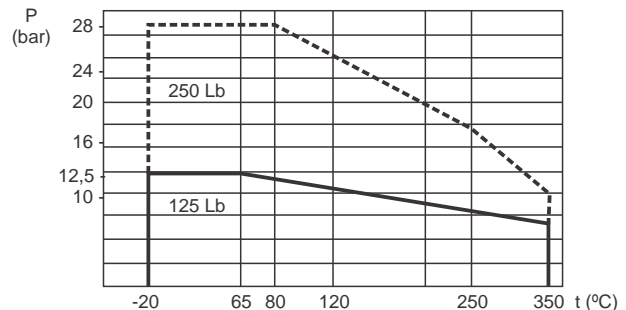

Fig. 3 - Flanges ANSI B 16.1. Accessible pressure according to temperature.

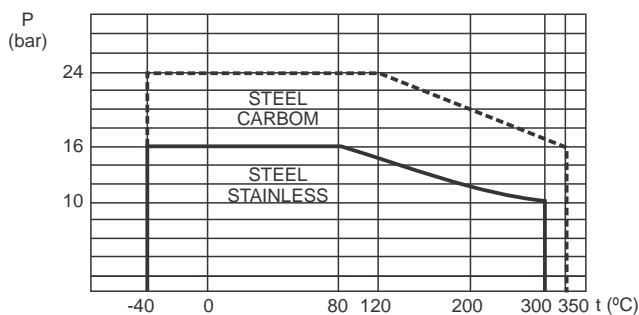

Fig. 2 Maximum discharge pressure according to temperature.

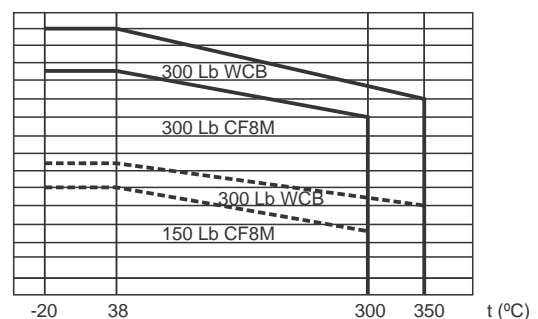

Fig. 4 - Flanges ANSI B 16.5. Accessible pressure according to temperature.

- Peripheral speed (m/s).

When determining the pump operation rotation, besides the maximum discharge pressure the maximum peripheral speed of the motor must be considered, according to its construction material.

GG 20	40 m/s
GGG 40	60 m/s
SAE 40	60 m/s
CF8M	80 m/s

- The **NPSH** values required are found in the characteristic curves of each model, being necessary to add 0.5 m as a measure fabrication safety.

- For the execution with a CF8M stainless steel impeller, it's necessary to reduce the outputs found in the characteristic curves according to what is indicated next:

Impeller width	Reduce
Up to 12 mm	3 points
From 12 to 15 mm	2 points
Over 15 mm	No reduction

- For the pump selection, use the characteristic curves that refer to water at room temperature and specific weight equal to 1.0 kgf/ dm³.

TECHNICAL DATA

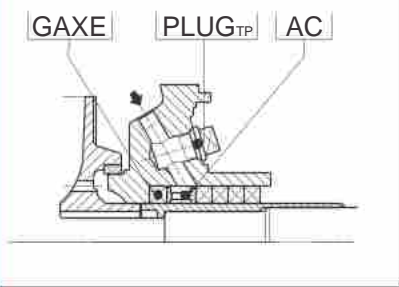
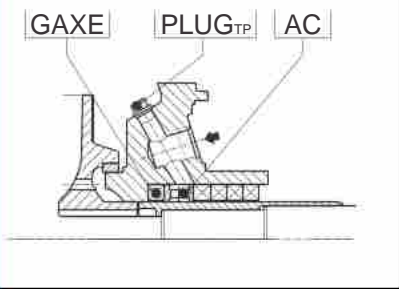
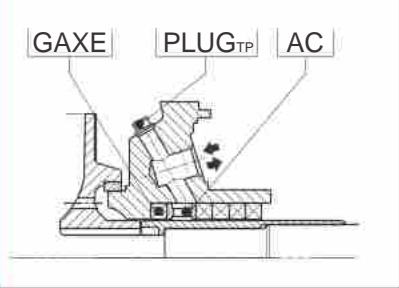
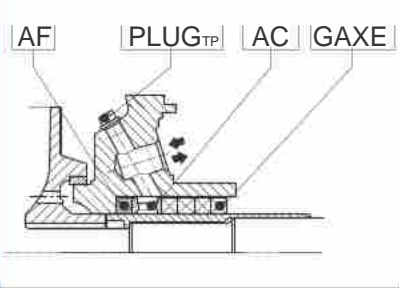
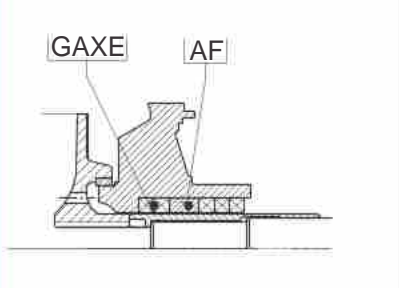
<p>1</p>		<p>Pumping of non-aggressive clear fluids. Sealing through internal source. Temperature up to 160°C.</p>
<p>2</p>		<p>Pumping of toxic, aggressive fluids and for pumps suctioning from a tank subject to vacuum. Sealing with clear liquid through external source. Temperature up to 105°C.</p>
<p>3</p>		<p>Pumping of fluids with suspended solid particles and/or when avoiding contamination from external source. Temperature up to 105°C.</p>
<p>4</p>		<p>Pumping of fluids with abrasive particles or particles prone to crystallization. Flushing with clear liquid from external source. Temperature up to 105°C.</p>
<p>5</p>		<p>Pumping of thermal oils with temperatures higher than 180°C (Rothatherm Packing).</p>

The manufacturing **codes 2, 3 and 4 may only be applied for models without refrigeration chamber.**

- Volumetric flow rate of sealing liquid (l/min):

Sealing = approximately 1 l/min

Washing = approximately from 3 to 5 l/min.

- Pressure of external sealing liquid (bar):

1 + $\frac{DP}{2}$ for models 32-125 and 32-160.

2

1 + SP for the all the other models.

DP = Discharge Pressure

SP = Suction Pressure

The driver is performed by means of flexible coupling, with or without spacer, by: electric motor, combustion engine, etc.

The driver may be performed by pulleys and belts as long as reinforced intermediate bearings are used.

- Power reserve for driver in relation to power consumed by pump (HP):

Up to 2 HP approximately 20% of reserve.

Up to 20 HP approximately 15% of reserve.

Over 20 HP approximately 10% of reserve.

The following accessories are optionally available:

- IMBIL standard coupling or from other manufacturers.

- IMBIL standard coupling protector.

- IMBIL standard base, in plate or U-shaped.

- IMBIL standard counterflange.

CROSS SECTION AND IDENTIFICATION OF PARTS

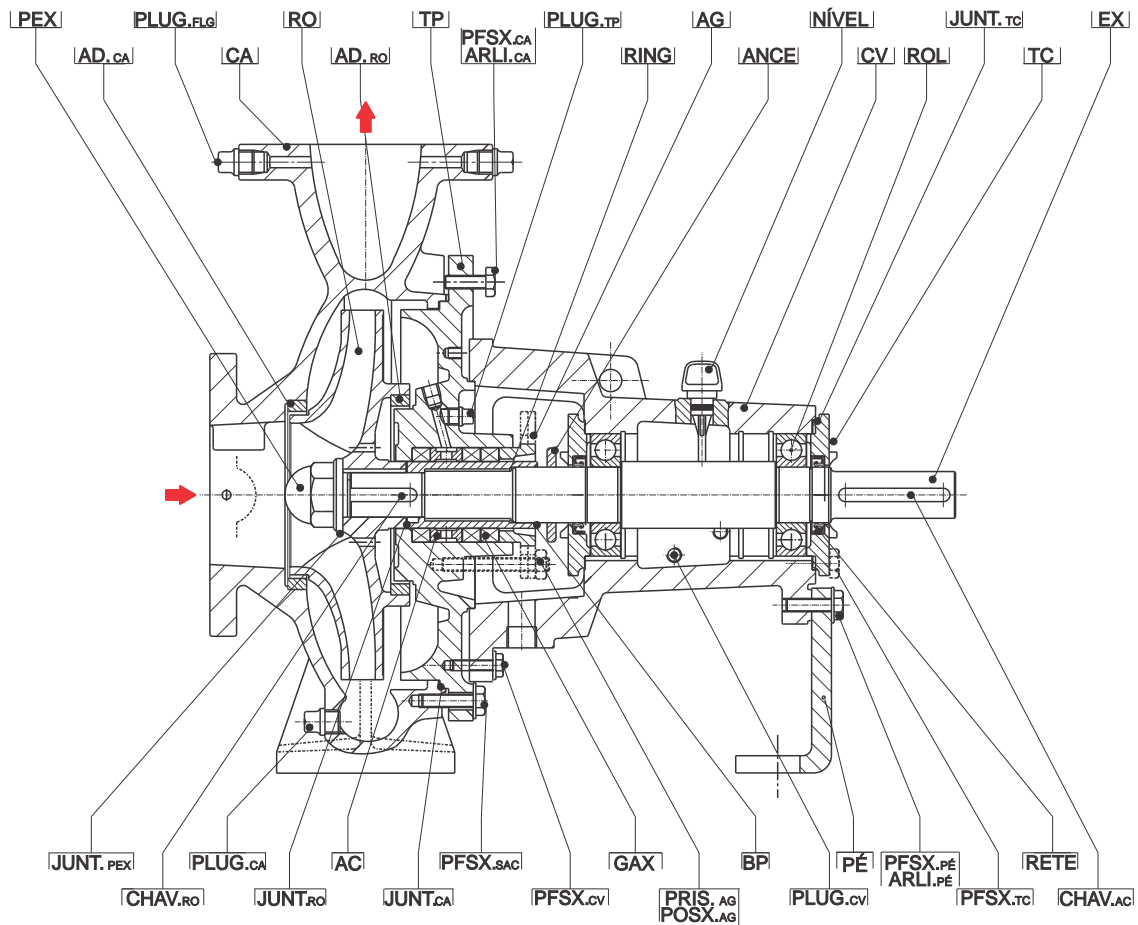

DETAIL OF PRESSURE COVER

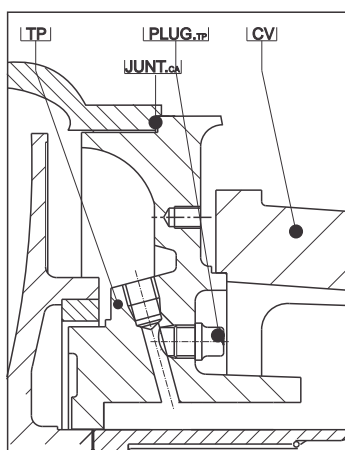

DETAIL COOLING CHAMBER

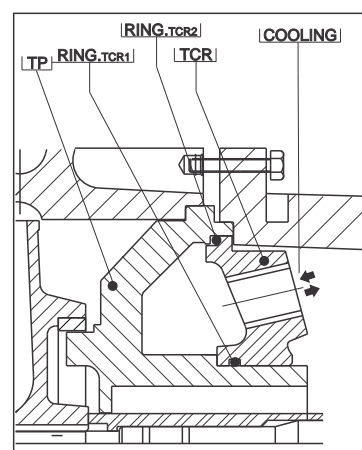

For Models

130	32, 40, 50, 65-125	32, 40, 50-160
140	65, 80-160	
150	125, 150-200	
160	150-315	



PART LIST – INI

Part	Denomination	Ref.	Material	Qty	Reference notes
AC	Lantern ring		A48 CL30	1	
ANCE	Centrifuge ring		Nylon	1	
AD.CA	Volute case wear ring		A48 CL30	1	
AD.RO	Impeller wear ring		A48 CL30	1	
AF	Back ring	1	A48 CL30	1	
AG	Stuffing box packing gland		A48 CL30	1	
ARLI.CA	Smooth washer of volute case	2	SAE 1020	8	① Only applicable for sealing codes 4 and 5
ARLI.PÉ	Smooth washer of feet		SAE 1020	1	
BP	Shaft sleeve		SAE 1020	1	
CA	Volute case		A48 CL30	1	
CV	Bearing Housing		GG-20	1	② Qty = 8 in models: 32/ 40/ 50/ 65/ 80/ 100-200 and 100-160
CHAV.ACP	Coupling Key		SAE 1045	1	Qty. = 10 in models: 32/ 40/ 50/ 65/ 80/ 100/ 125 and 150-250
CHAV.RO	Impeller key		SAE 1045	1	Qty. = 12 in models: 40/ 50/ 65/ 80/ 100 and 125-315
EX	Shaft		SAE 1045	1	Qty. = 16 in models: 80/ 100/ 125 and 150-400
GAXE	Packing		Graphitized	1	
JUNT.CA	Volute case joint		K. oilit	1	
JUNT.PEX	Shaft nut joint		K. oilit	1	
JUNT.TC	Bearing housing cover joint		Velumoiide	2	
JUNT.RO	Impeller joint		K. oilit	1	③ Only applicable for models with refrigeration
RING.BP	Shaft sleeve o'ring		Nitrilic	1	
RING.TCR1	Refrigeration cover o'ring	3	Nitrilic	1	
RING.TCR2	Refrigeration cover o'ring	3	Nitrilic	1	
PFSX.CA	Volute case screw	2	SAE 1020	8	④ Qty. = 6 for bearing housing I30 and I40.
PFSX.TC	Bearing housing cover screw		SAE 1020	8	Qty. = 8 for bearing housing I50 and I60.
PFSX.CV	Bearing housing screw	4	SAE 1020	6	
PFSX.PÉ	Feet screw		SAE 1020	1	
PFSX.SAC	Cover opener screw	5	SAE 1020	1	⑤ Only applicable in models: 32/ 40/ 50/ 65/ 80/ 100-200
PÉ	Feet		GG-20	1	32/ 40/ 50/ 65/ 80/ 100/ 125/ 150-250
PLUG.CA	Volute case plug		Galvanized iron	1	40/ 50/ 65/ 80/ 100 and 125-315
PLUG.FLG	Flange plug		Galvanized iron	3	80/ 100/ 125 and 150-400
PLUG.TP	Pressure cover plug		Galvanized iron	2	100-160
PLUG.CV	Bearing housing plug		Galvanized iron	2	
POSX.AG	Stuffing box packing gland nut		SAE 1020	2	
PEX	Shaft nut		SAE 1045	1	
PRIS.AG	Tap bolt of stuffing box		SAE 1045	2	
RETE	Retainer		Nitrilica	2	
ROL	Ball bearing		Steel	2	
RO	Impeller		GG-20	1	
TCR	Refrigeration chamber cover	3	GG-20	1	
TP	Pressure cover		GG-20	1	
TC	Bearing housing cover		GG-20	2	
Nivel	Oil dip stick		Nylon	1	

Note: The materials specified for the parts are for standard pumps. The parts can be manufactured in the following materials: nodular iron, carbon steel, stainless steel, bronze, aluminum and special alloys and or other material according to the purpose of the pump.

INI-BLOC PUMP

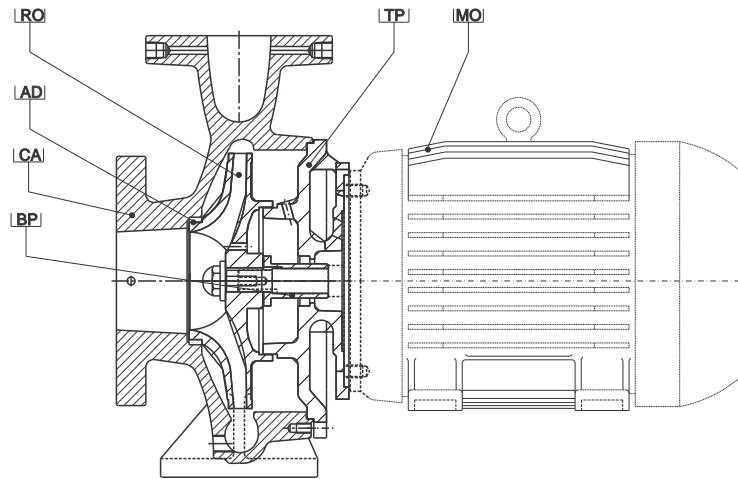

INI-BLOC PUMP (With coupling pieces)

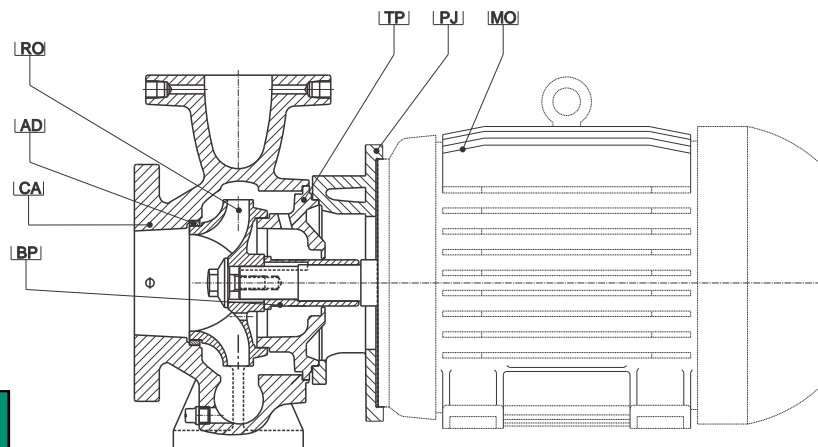

Part	Qty.	Denomination
AD	01	Wear Ring
BP	01	Shaft Sleeve
CA	01	Volute Case
MO	01	Engine
PJ*	01	Coupling Piece
RO	01	Impeller
TP	01	Pressure Cover

* Used only some models, when required



BASIC DIMENSIONS (mm) – INI

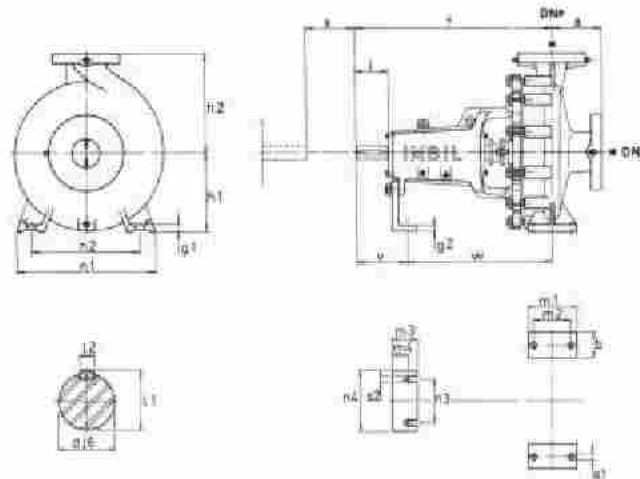

Bearing Housing	Models	Pump dimensions													Feet dimensions										Shaft End				
		DN _s	DN _p	a	T	h ₁	h ₂	D	g ₁	g ₂	m ₁	m ₂	m ₃	m ₄	n ₁	n ₂	n ₃	n ₄	s ₁	s ₂	v	w	d ₁	l	l ₁	l ₂	x		
I 30	25-150	32	25	73	400	112	160	50	15	6,5	100	70	64	38	190	140	110	152,4	14	14	118	282	24	50	26,9	8	100		
	32-125,1	50	32	80	385	112	160	50	15	6,5	100	70	64	38	190	140	110	152,4	14	14	118	282	24	50	26,9	8	100		
	32-160,1	50	32			132	160								240	190													
	32-200,1	50	32			160	180								240	190													
	32-125	50	32			112	160								190	140													
	32-160	50	32			132	160								240	190													
	32-200	50	32			160	180								240	190													
	40-125	65	40			112	140								210	160													
	40-160	65	40			132	160								240	190													
	40-200	65	40			160	180								265	212													
	50-125	80	50			132	160								240	190													
	50-160	80	50			160	180								265	212													
50-200	80	50	160			200	265								212														
65-125	100	50	160	180	280	212																							
I 40	32-250,1	50	32	100	500	180	225	65	18	9,5	125	95	64,5	39,5	320	250	110	152,4	14	14	130	370	32	80	35,3	10	100		
	32-250	50	32	100		180	225								320	250													
	40-250	65	40	100		180	225								320	250													
	50-250	80	50	125		180	225								320	250													
	65-160	100	65	125		160	200								280	212													
	65-200	100	65	100		180	225								320	250													
I 40 R	80-160	125	80	100	500	180	225	80	9,5	125	95	64,5	39,5	360	280	110	152,4	14	14	130	370	32	80	35,3	10	140			
	65-250	100	65	100		200	250							360	280														
	80-250	125	80	100		225	280							400	315														
	100-160	125	100	100		200	280							360	280														
	100-200	125	100	125		200	280							360	280														
	40-315	65	40	100		200	250							345	280														
	50-315	80	50	100		225	280							345	280														
	60-200	125	80	100		180	250							345	280														
I 50	65-315	100	65	125	530	225	280	80	9,5	160	120	61,5	36,5	400	315	110	152,4	18	14	160	370	42	110	45,1	12	140			
	80-315	125	80	125		250	315							400	315														
	80-400	125	80	125		280	355							435	315														
	100-250	125	100	140		225	280							400	315														
	100-315	125	100	140		250	315							400	315														
	125-200	150	125	140		250	315							400	315														
	125-250	150	125	140		250	355							400	315														
	100-400	125	100	140		280	355							500	400														
	125-315	150	125	140		280	355							500	400														
	125-400	150	125	140		315	400							500	400														
	150-200	200	150	160		280	375							500	400														
	150-250	200	150	160		280	375							500	400														
I 60	150-315	200	150	160	670	315	400	100	20	15	200	150	38	550	450	140	210	2,2	20	170	500	48	110	51,1	14	180			
	150-400	200	150	160	670	400	400	100	20	15	200	150	38	550	450	140	210	2,2	20	170	500	48	110	51,1	14	180			

BASIC DIMENSIONS (mm) – INI-BLOC

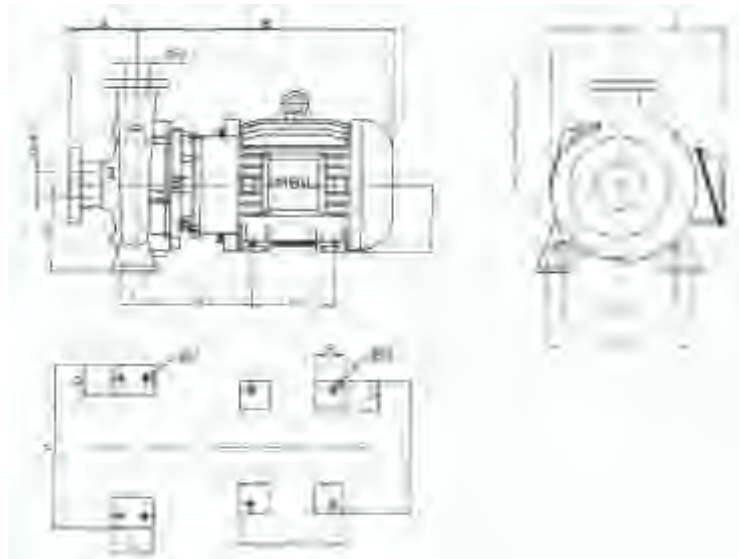

Model	Motor		Dimensions																							
	4 POLOS	2 POLOS	Dns	Dnp	A	B	C	D	E	F	G	H	J	L	M	N	P	Q	R	S	T	U	ØV1	ØV2	X	
32-125		2/3 CV	50	32	80	361	89	150	112	70	138	100	90	140	140	190	50	190	42	38	164	131	14	10	10	156
		4 CV				386	125	156																		
		5 CV				411	99	173																		
		6/ 7,5 CV				432	112	177																		
32-160		2/3 CV	50	32	80	363	89	150	132	70	140	100	90	140	160	240	50	190	42	38	164	131	14	10	100	156
		4 CV				388	125	156																		
		5 CV				413	99	173																		
		6/ 7,5 CV				434	112	177																		
32-200	1,5/ 2 CV		50	32	80	360	89	150	160	95	137	100	90	180	190	240	50	320	42	38	164	131	14	10	156	
	3 CV					385	125	156																		
		6/ 7,5 CV				431	112	177																		
		10 CV				471	135	187																		
32-250		20/ 25 CV	65	40	100	509	178	225	180	95	205	210	160	225	254	320	65	250	65	64	308	225	14	15	125	256
		30 CV				614	155	210																		
		40 CV				177	241	294																		
						195	267	332																		
40-125		4 CV	65	40	80	387	89	150	112	70	139	125	90	140	160	210	50	210	42	38	164	156	14	10	173	
		5 CV				412	99	173																		
		6/ 7,5 CV				433	112	177																		
		10 CV				473	135	187																		
40-160	1,5/ 2 CV		65	40	80	364	89	150	132	70	140	100	90	160	190	240	50	240	42	38	164	131	14	10	100	156
		10 CV				476	135	187																		
		12,5/ 15 CV				514	178	225																		
		20 CV				616	155	256																		
40-200	3 CV		65	40	100	385	89	150	160	95	137	125	90	180	212	265	65	265	42	38	164	156	14	10	173	
	4 CV					514	99	173																		
		20/ 25 CV				614	155	210																		
		30 CV				677	177	241																		
40-250	4/ 5 CV		65	40	100	408	99	140	180	95	120	140	100	225	254	320	65	250	50	44	188	173	14	12	125	177
	6 CV					429	112	177																		
		25 CV				-	155	210																		
		30 CV				678	177	241																		
		40 CV	65	40	100	744	267	332	180	95	207	241	180	225	279	320	65	250	75	80	350	294	14	15	125	370
		50 CV				782	195	305																		
						219	305	200																		
						219	305	200																		



BASIC DIMENSIONS (mm) – INI-BLOC

Model	Motor		Dimensions																								
	4POLD5	2POLD5	Dax	Eng	A	B	C	D	E	F	G	H	J	L	M	N	P	Q	R	S	T	U	V1	V2	W		
50-125	1/1,5 CV					-	89	150			-	100	90		140					42	38	164	131		10		
	10 CV					476	135	140	132		165	140	132	160	216	190	240			55	51	248	187		12		
	12,5/15 CV					514		178				178											225				
50-160	3 CV					-	89	150			-	125	90		140					42	38	164	156		10		
	4 CV						99	140				140	100	180	160					50	44	188	173		12		
50-200	20/25 CV		80	50	100	616	155	210			207	210	160		254					65	64	308	256		15	100	
	4/5 CV					411	99	140		70	135	140	100		160					50	44	188	173		12		
	6 CV					432	112	140	160		142	140	112		190		212	265	50		48	220	177		15		
50-250	25 CV					615	155	210			206	210	160	200	254					65	64	308	256		15		
	30 CV					678	177	241			219	241			279					75	80	350	294		15		
	40 CV					744	195	267			231	267	180		318					85	82	385	332		19		
50-315	6 CV					-	112		180		-		112	225	190		250	320		50	48	220	177		12		
	7,5/10 CV					474					150												187		12		
65-125	10 CV			125		470	135	140			146	140	132	280	216	280	345			55	51	248	187		12		
	12,5/15 CV					508		178	225			178											225		14		
	20 CV						155	210				210	160		254					65	64	308	256		15		
65-160	2 CV					-	89	150			-	100	90		140					42	38	164	131		10		
	15 CV						135	178				178	132	180	216					55	51	248	225		12		
	20 CV					314	155	210			193	210	160		254					55	64	308	256		15		
65-200	4 CV					414	99	140		160	125	140	100		160		212	280	65	50	44	188	173		12	125	
	25 CV					622	155	210			196	210	160	200	254					65	64	308	256		15		
	30 CV					679	177	241			209	241	180		279					75	80	350	294		15		
65-250	40 CV					745	195	267			211	267	200		318					85	82	385	332		19		
	4/5 CV		100	65	100		99					100		160						50	44	188	173		12		
	6 CV					122		140	180			140	112	190						55	48	220	177		12		
65-315	7,5/10 CV					135						132		216						55	51	248	187		12		
	30 CV					177	241				241	180	225	279	250	320				75	80	350	294		15		
	40 CV					195	267	305			267	305	200	318						85	82	385	332		19		
65-350	50 CV						305				305			318						85	82	385	370		19		
	7,5/10 CV					472		140	200		136	140		250	216	280	360			55	51	248	187		12	160	
	12,5/15 CV					510	135	178		120		178	132	280	216			80				225		18			
65-400	15 CV					-					-									65	64	308	256		15		
	20 CV					604	155	210	225		170	210	160	280	254	315	400			75	80	350	294		15		
	25/30 CV					667	177	241			183	241	180		279					75	80	350	294		15		
80-160	5 CV					99						100		160						50	44	188	173		12	125	
	6 CV					112		180		95		112	225	190	250					55	48	220	177		12		
	7,5 CV					135	140					140	135	216		320	65			55	51	248	187		14		
80-200	6 CV					112				95		112		190						50	48	220	177		12		
	7,5/10 CV					125		200					250		280					50	48	220	177		12		
	12,5/15 CV					125	80	125						216						55	51	248	225		12		
80-250	20 CV					502			225		128	178	132	280						65	64	308	256		15		
	25/30 CV					604	155	210			170	210	160	280	254					75	80	350	294		15		
	40 CV					674	177	241			190	241	180		279	315	400			75	80	350	294		15		
80-315	50 CV					740	195	267	250		202	267	200	315	305					85	82	385	332		19		
	60 CV					778	195	305			202	305	200	315	305					85	82	385	370		19		
	12,5/15 CV					604	135	178			230	178	132		216	280	360	80		55	51	248	225		12	160	
100-200	20 CV						155	210		200	120	210	160	280	254					65	64	308	256		15		
	25/30 CV						177	241	225			241	180	20	279					75	80	350	294		15		
	40 CV						195	267	250			267	200	315	318	315	400			85	82	385	332		19		
100-250	50 CV						305					305								85	82	385	370		19		
	60 CV						305					305								85	82	385	370		19		
	75 CV				140	830	243	280	280	150	199	286	225	355	356	400	500	100		105	80	436	391	22		200	
125-200	20 CV					610	155	210			176	210	160		254					65	64	308	256		15		
	25 CV						177	241	250	120		241	180		279	315	400	80		75	80	350	294		18	15	160
	25/30 CV						195	267				267		355						85	82	385	332		19		
125-250	40 CV						305					305								85	82	385	370		19		
	50 CV						305					305								85	82	385	370		19		
	60 CV						305					305								85	82	385	370		19		
150-200	20 CV						155	210				210	160		254					65	64	308	256		15		
	25/30 CV					668	177	241			169	241	180		279	450	550			75	80	350	294		15		
	40 CV						195	267	280	150		267	200	375	315	400	500	100		85	82	385	332	22	19	200	
150-250	50 CV						305					305								85	82	385	370		19		
	60 CV						243	286				286	225		356					105	80	436	391				



CONNECTION SIZES AND FLANGE TABLE

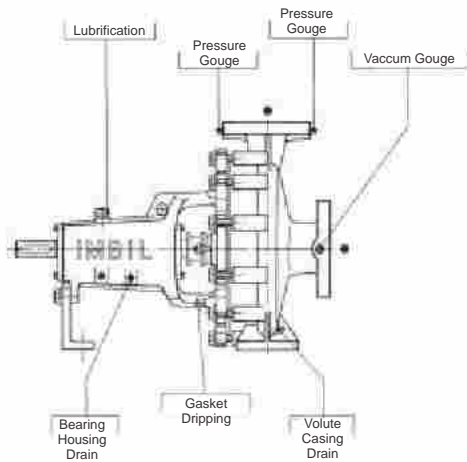

Detail of the cooling cap

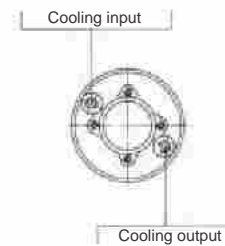

Connection / Denomination	BSP screw threads				
	I 30	I 40	I 40 R	I 50	I 60
Pressure gauge	3/8"	3/8"	3/8"	1/2"	1/2"
Pressure/Vacuum Meter	3/8"	3/8"	3/8"	1/2"	1/2"
Volute case drain	3/8"	3/8"	3/8"	1/2"	1/2"
Bearing Housing Drain	1/4"	1/4"	1/4"	1/4"	1/4"
Lubrication	-	-	-	-	-
Dripping	1/2"	1/2"	1/2"	3/4"	3/4"
Inlet refrigeration	1/2"	1/2"	1/2"	1/2"	1/2"
Outlet refrigeration	1/2"	1/2"	1/2"	1/2"	1/2"

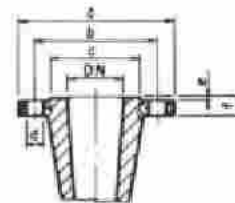
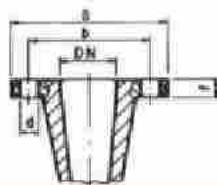

	ANSI B-16.1FF Standard	a	b	d	f	Number of holes
25	125 Lb	108	79	16	11	4
	250 Lb	124	89	19	18	4
32	125 Lb	117	89	16	13	4
	250 Lb	133	98	19	17	4
40	125 Lb	127	98	16	14	4
	250 Lb	155	114	22	19	4
50	125 Lb	152	120	19	16	4
	250 Lb	165	127	19	20	8
65	125 Lb	178	140	19	17	4
	250 Lb	190	149	22	24	8
80	125 Lb	190	152	19	19	4
	250 Lb	209	168	22	27	8
100	125 Lb	228	190	19	24	8
	250 Lb	254	200	22	30	8
125	125 Lb	254	216	22	24	8
	250 Lb	279	235	22	35	8
150	125 Lb	279	241	22	25	8
	250 Lb	317	270	22	36	12
200	125 Lb	343	298	22	28	8
	250 Lb	381	330	25	41	12

	ANSI B 16.1FF Standard	a	b	c	d	e	f	Number of holes
25	150 Lb	110	79,4	50,8	16	2,0	14,7	4
	300 Lb	125	88,9	50,8	19	2,0	17,9	4
32	150 Lb	115	88,9	63,5	16	2,0	16,3	4
	300 Lb	135	98,4	63,5	19	2,0	19,5	4
40	150 Lb	125	98,4	73,0	16	2,0	17,9	4
	300 Lb	155	114,3	73,0	22	2,0	21,1	4
50	150 Lb	150	120,7	92,1	19	2,0	19,5	4
	300 Lb	165	127,0	92,1	19	2,0	22,7	8
65	150 Lb	180	139,7	104,8	19	2,0	22,7	4
	300 Lb	190	149,2	104,8	22	2,0	25,9	8
80	150 Lb	190	125,4	127,0	19	2,0	24,3	4
	300 Lb	210	168,3	127,0	22	2,0	29,0	8
100	150 Lb	230	190,5	157,2	19	2,0	24,3	8
	300 Lb	255	200,0	157,2	22	2,0	32,2	8
125	150 Lb	255	215,9	185,7	22	2,0	24,3	8
	300 Lb	280	235,0	185,7	22	2,0	35,4	8
150	150 Lb	280	241,3	215,9	22	2,0	25,9	8
	300 Lb	320	269,9	215,9	22	2,0	37,0	12
200	150 Lb	345	298,5	269,9	22	2,0	29,0	8
	300 Lb	380	330,2	269,9	25	2,0	41,7	12

INI 32-125.1 3500 rpm

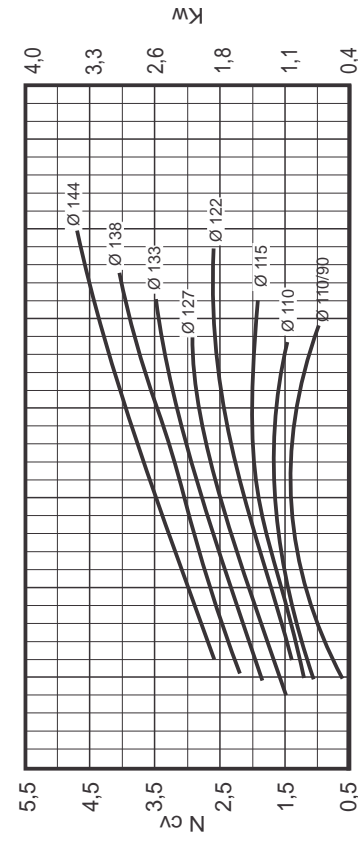
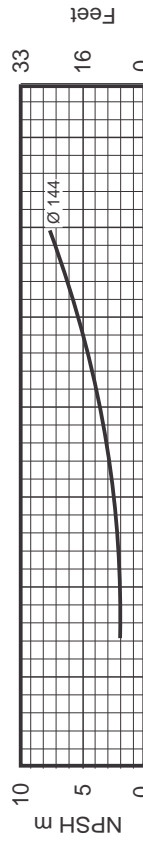
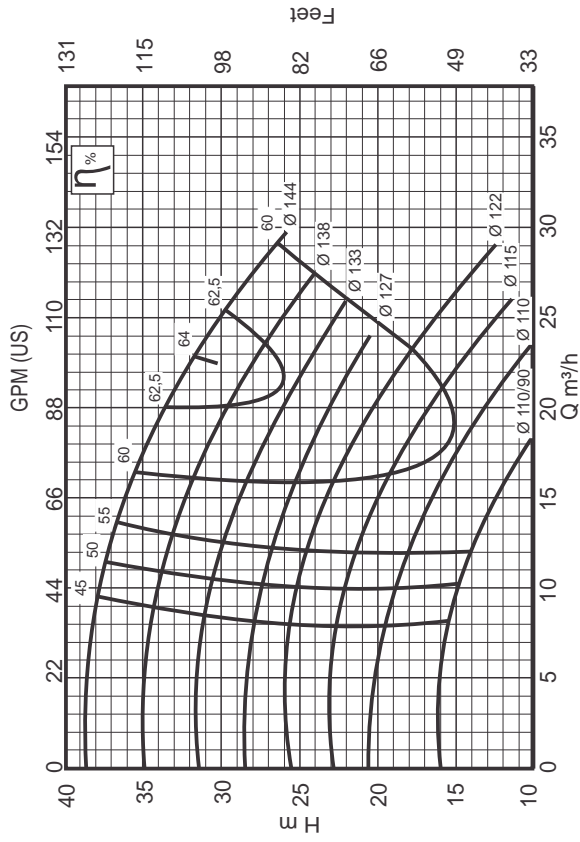

Impeller Ø Max. 144 mm
Impeller Ø Min. 110/90 mm
Impeller of Width 9 mm
Viscosity $\mu = 1\text{cP}$

Suction Flange 50 mm
Pressure Flange 32 mm
Specific Weight $\gamma = 1\text{kgf/dm}^3$

INI 32-125 3500 rpm

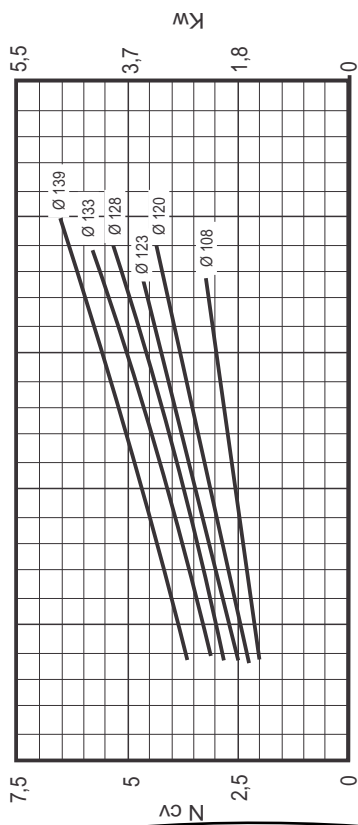
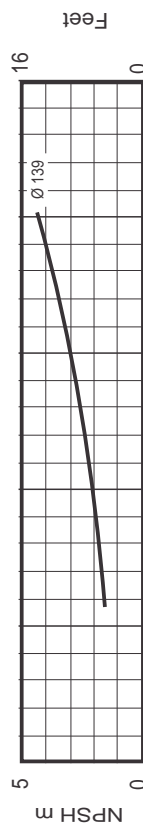
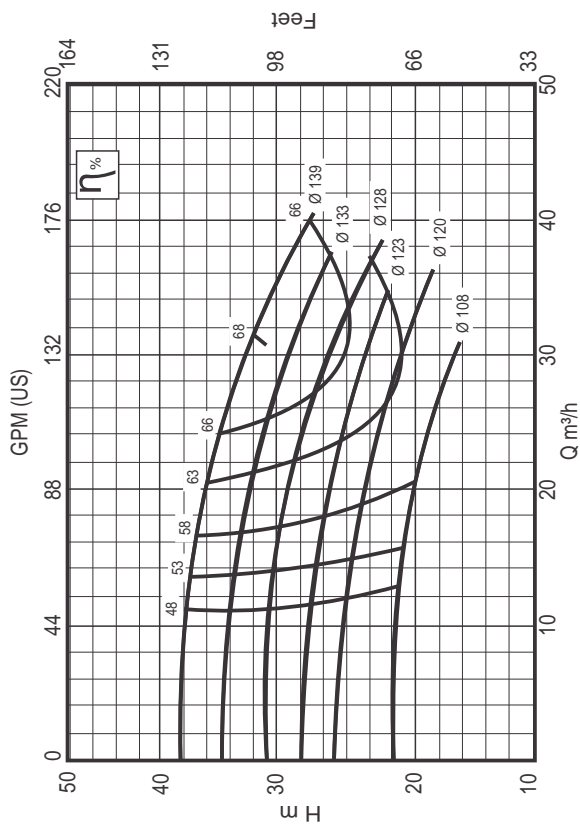

Impeller Ø Max. 139 mm
Impeller Ø Min. 108 mm
Impeller of Width 9 mm
Viscosity $\mu = 1\text{cP}$

Suction Flange 50 mm
Pressure Flange 32 mm
Specific Weight $\gamma = 1\text{kgf/dm}^3$

INI 32-160.1 3500 rpm

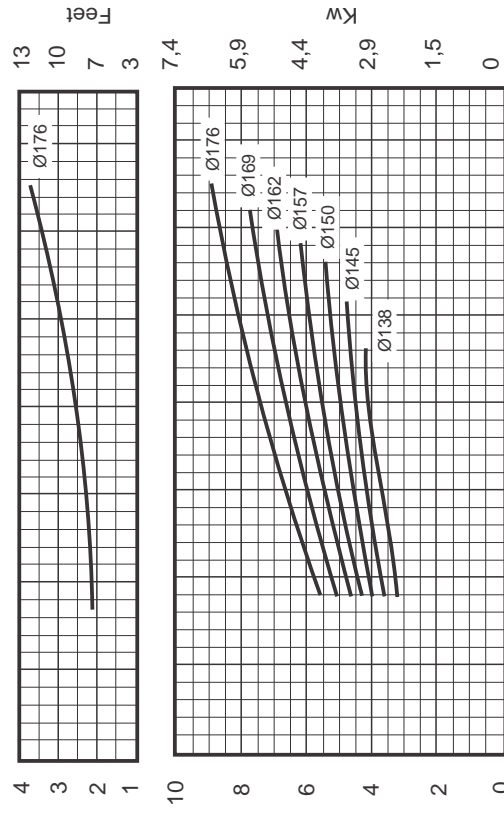
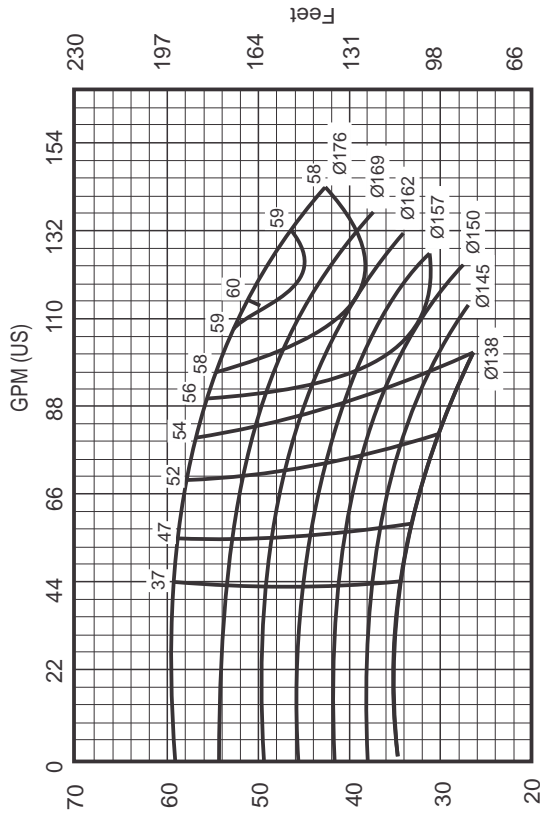

Suction Flange 50 mm
Pressure Flange 32 mm
Specific Weight $\gamma = 1 \text{ kgf/dm}^3$

Impeller Ø Max. 176 mm
Impeller Ø Min. 138 mm
Viscosity $\mu = 1 \text{ cP}$

INI 32-160 3500 rpm

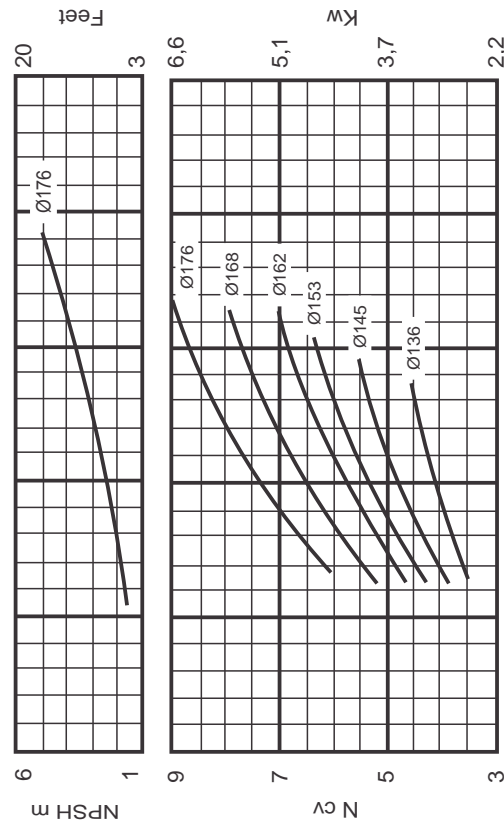
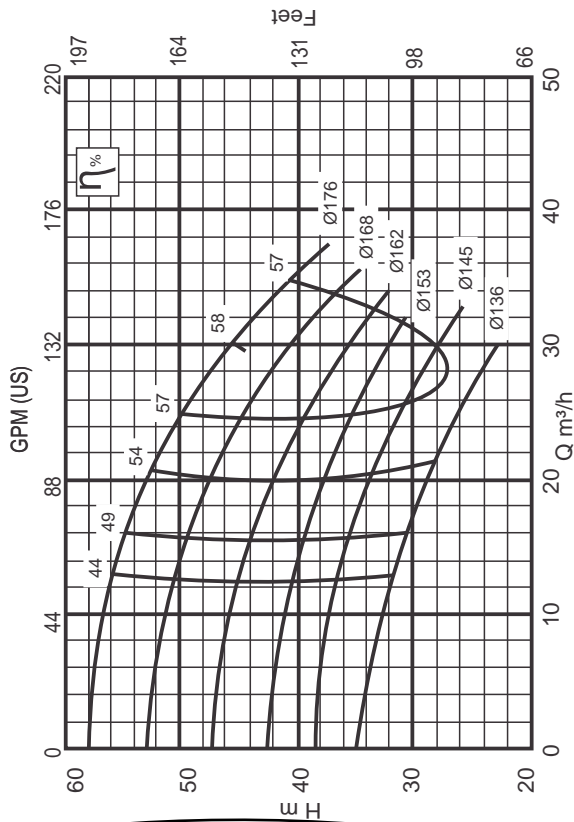

Suction Flange 50 mm
Pressure Flange 32 mm
Specific Weight $\gamma = 1 \text{ kgf/dm}^3$

Impeller Ø Max. 176 mm
Impeller Ø Min. 136 mm
Impeller of Width 5 mm
Viscosity $\mu = 1 \text{ cP}$

INI 32-200.1 3500 rpm

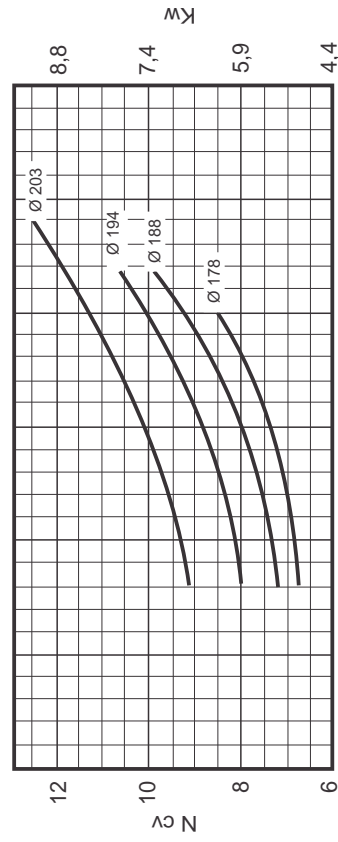
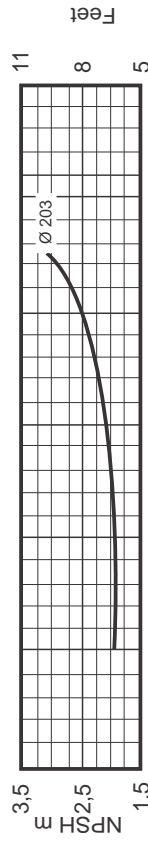
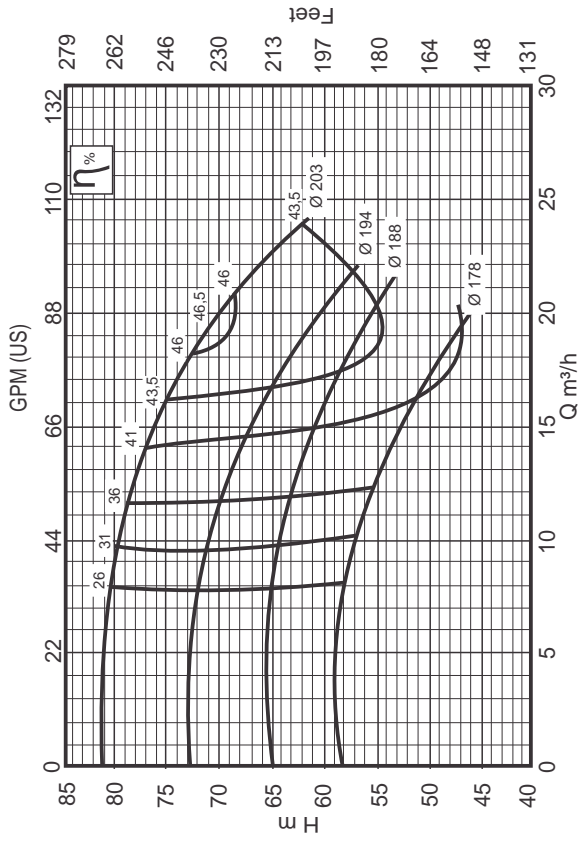

Suction Flange 50 mm
Pressure Flange 32 mm
Specific Weight $\gamma = 1 \text{ kgf/dm}^3$

Impeller Ø Max. 203 mm
Impeller Ø Min. 178 mm
Viscosity $\mu = 1 \text{ cP}$

INI 32-200 3500 rpm

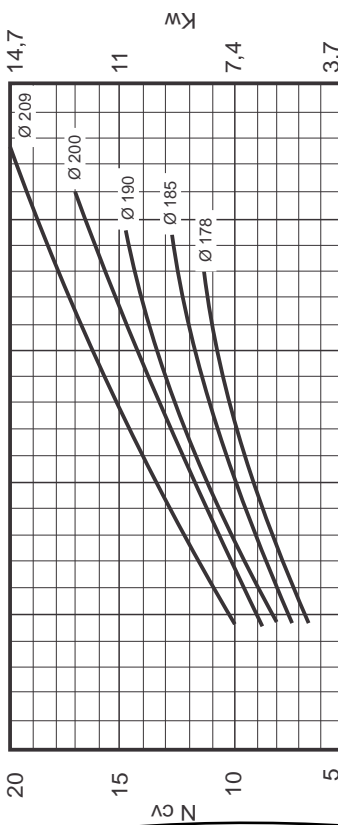
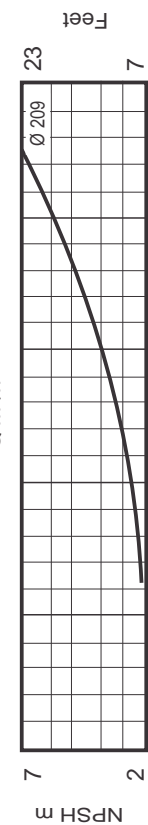
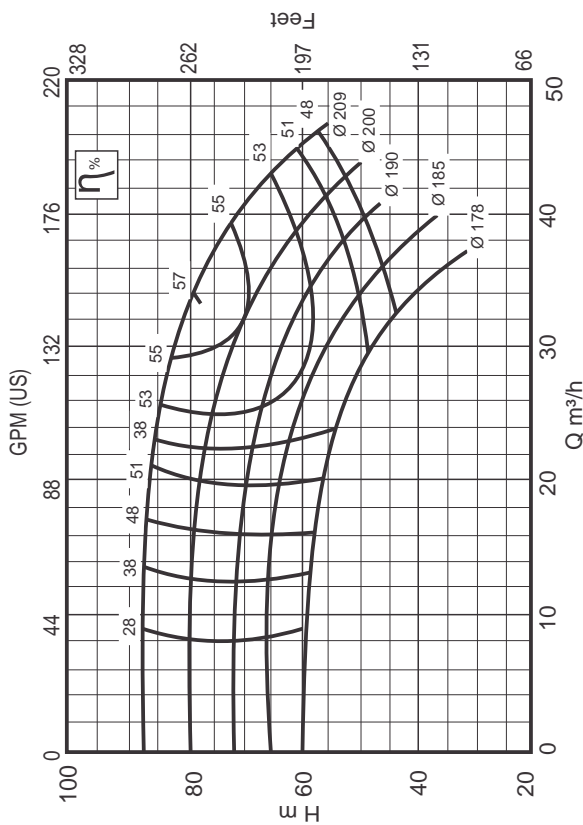

Suction Flange 50 mm
Pressure Flange 32 mm
Specific Weight $\gamma = 1 \text{ kgf/dm}^3$

Impeller Ø Max. 209 mm
Impeller Ø Min. 178 mm
Impeller of Width 6 mm
Viscosity $\mu = 1 \text{ cP}$

INI 32-250.1 3500 rpm

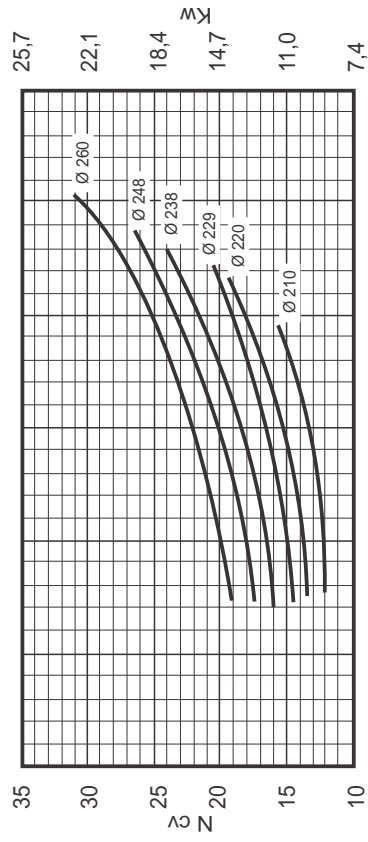
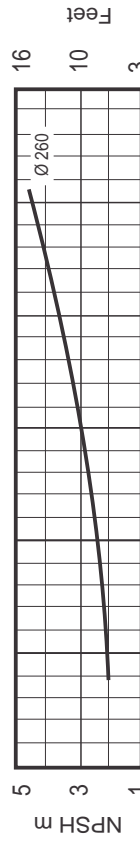
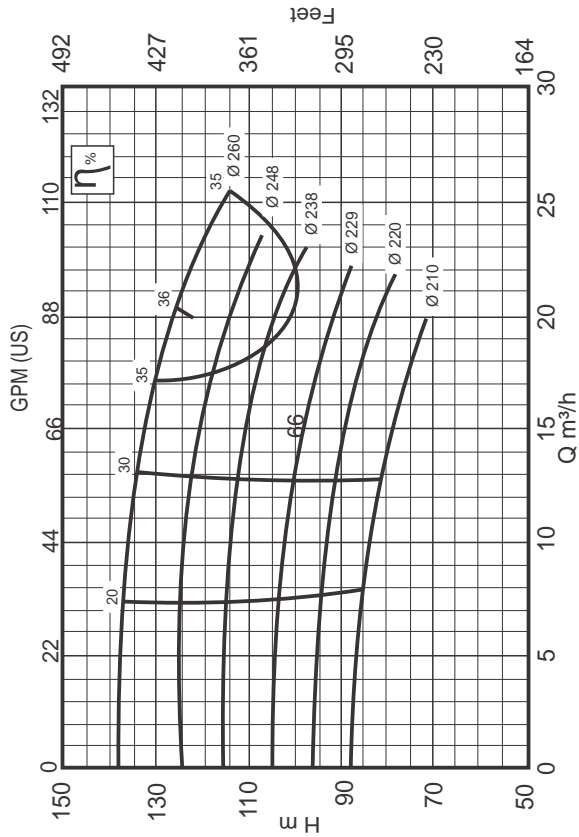

Impeller Ø Max. 260 mm
Impeller Ø Min. 210 mm
Viscosity $\mu = 1\text{cP}$

Suction Flange 50 mm
Pressure Flange 32 mm
Specific Weight $\gamma = 1\text{kgf/dm}^3$

INI 32-250 3500 rpm

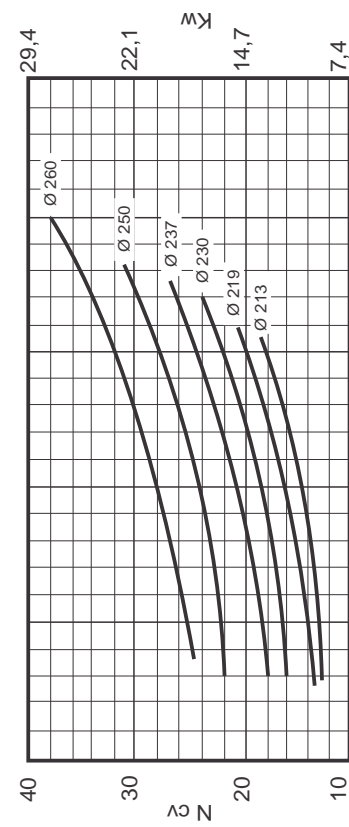
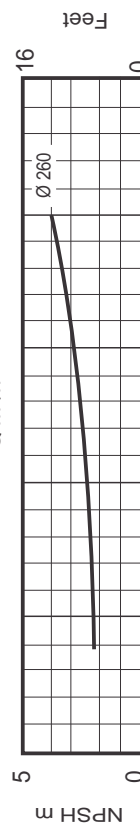
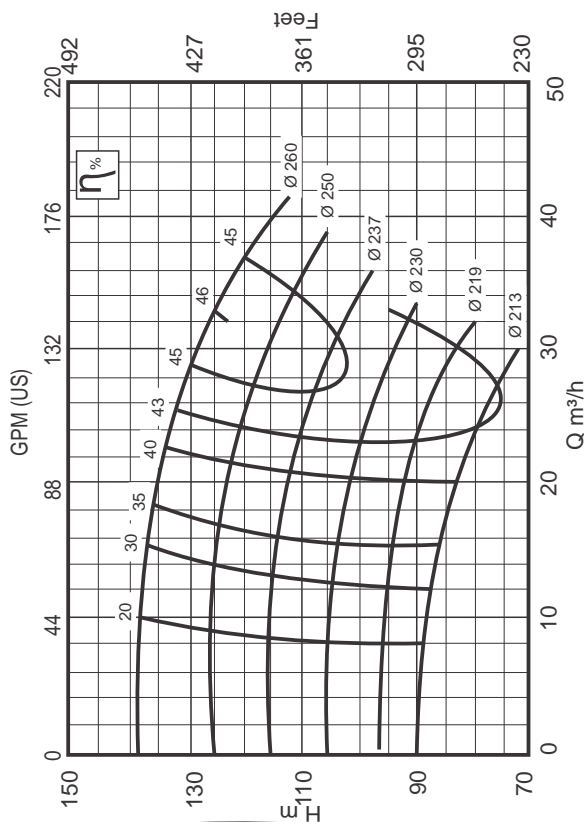

Impeller Ø Max. 260 mm
Impeller Ø Min. 213 mm
Impeller of Width 8 mm
Viscosity $\mu = 1\text{cP}$

Suction Flange 50 mm
Pressure Flange 32 mm
Specific Weight $\gamma = 1\text{kgf/dm}^3$

3500 rpm

INI 40-160

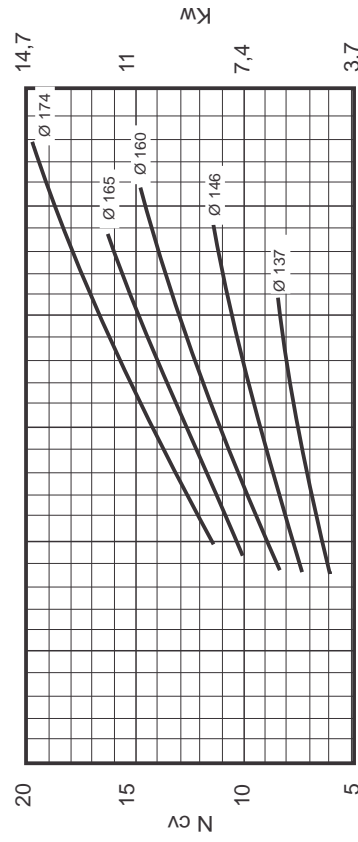
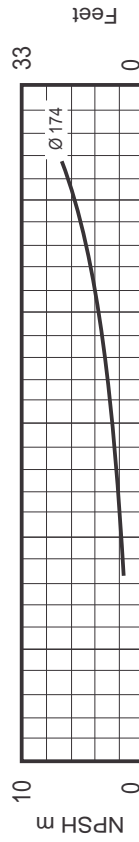
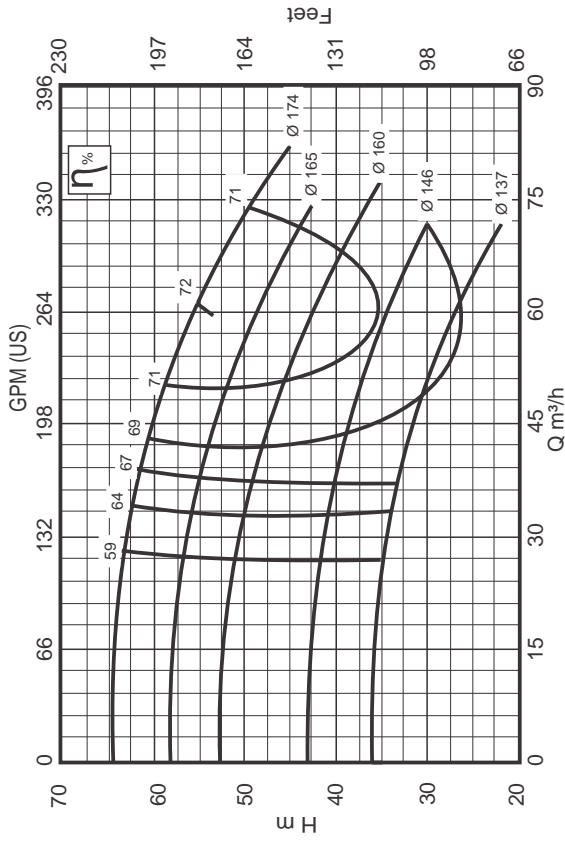

Suction Flange 65 mm
Pressure Flange 40 mm
Specific Weight $\gamma = 1 \text{ kgf/dm}^3$

Impeller Ø Max. 174 mm
Impeller Ø Min. 137 mm
Impeller of Width 12 mm
Viscosity $\mu = 1 \text{ cP}$

3500 rpm

INI 40-125

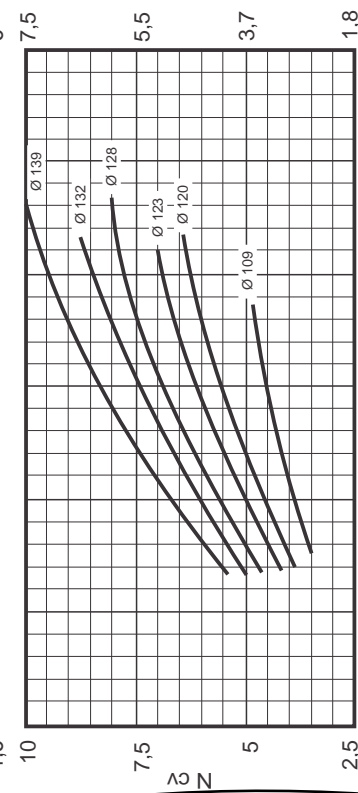
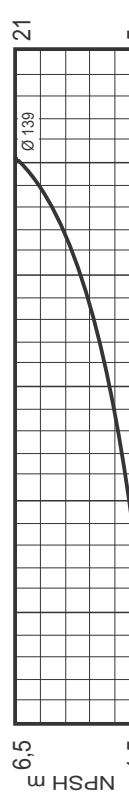
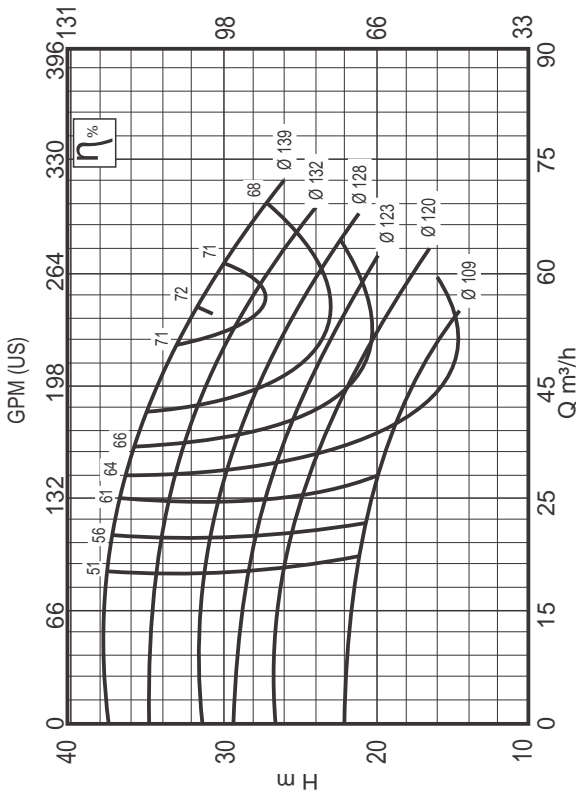

Suction Flange 65 mm
Pressure Flange 40 mm
Specific Weight $\gamma = 1 \text{ kgf/dm}^3$

Impeller Ø Max. 139 mm
Impeller Ø Min. 109 mm
Impeller of Width 14 mm
Viscosity $\mu = 1 \text{ cP}$

3500 rpm

INI 40-250

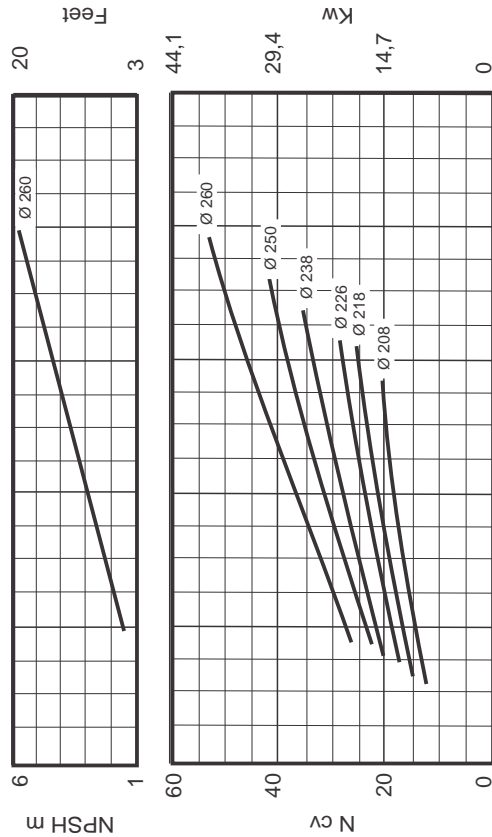
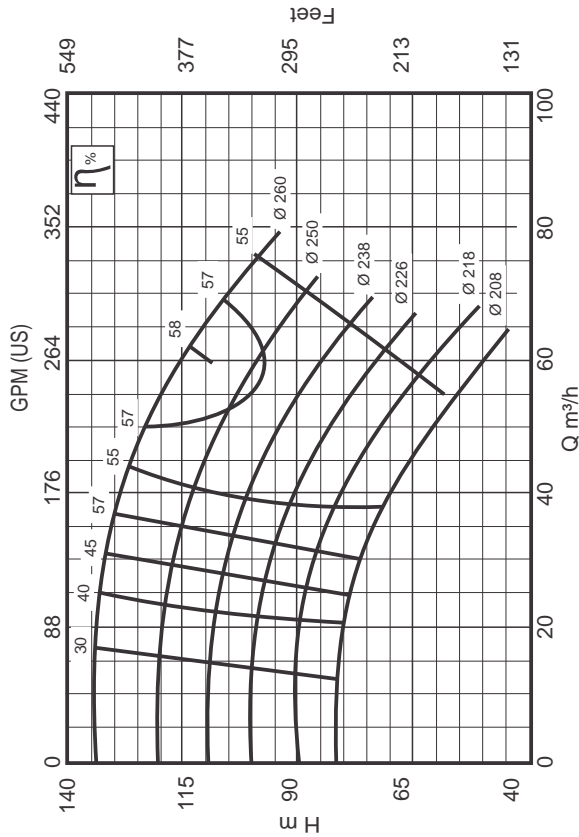

Suction Flange 65 mm
Pressure Flange 40 mm
Specific Weight $\gamma = 1 \text{ kgf/dm}^3$

Impeller Ø Max. 260 mm
Impeller Ø Min. 208 mm
Impeller of Width 8 mm
Viscosity $\mu = 1 \text{ cP}$

3500 rpm

INI 40-200

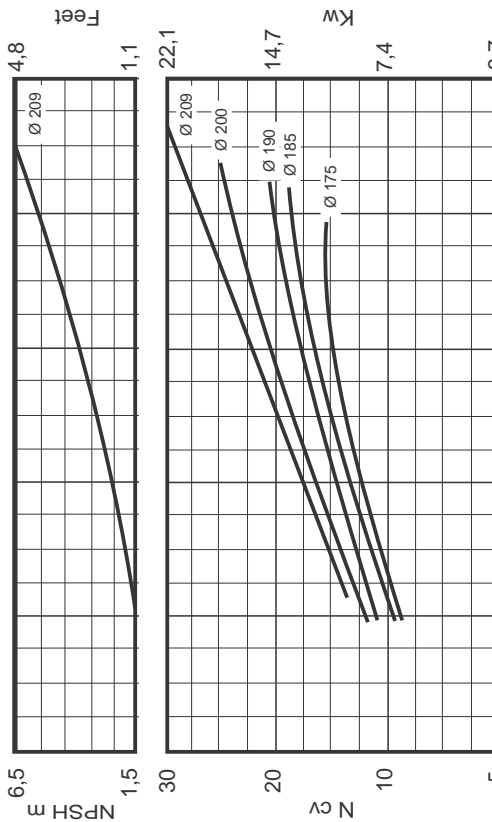
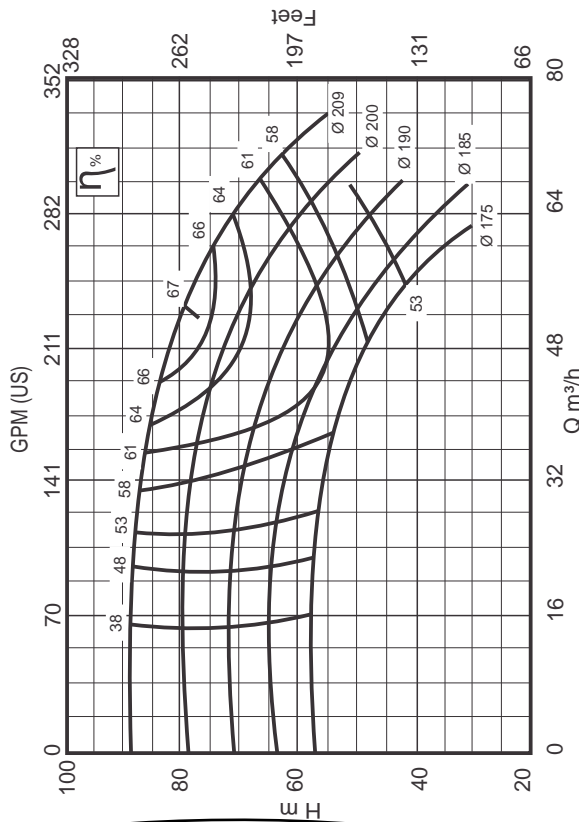

Suction Flange 65 mm
Pressure Flange 40 mm
Specific Weight $\gamma = 1 \text{ kgf/dm}^3$

Impeller Ø Max. 209 mm
Impeller Ø Min. 175 mm
Impeller of Width 9 mm
Viscosity $\mu = 1 \text{ cP}$

INI 50-200

3500 rpm

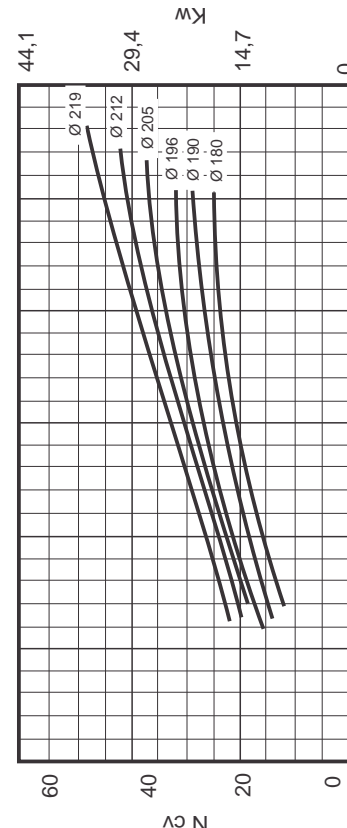
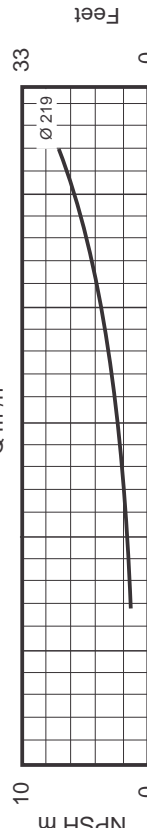
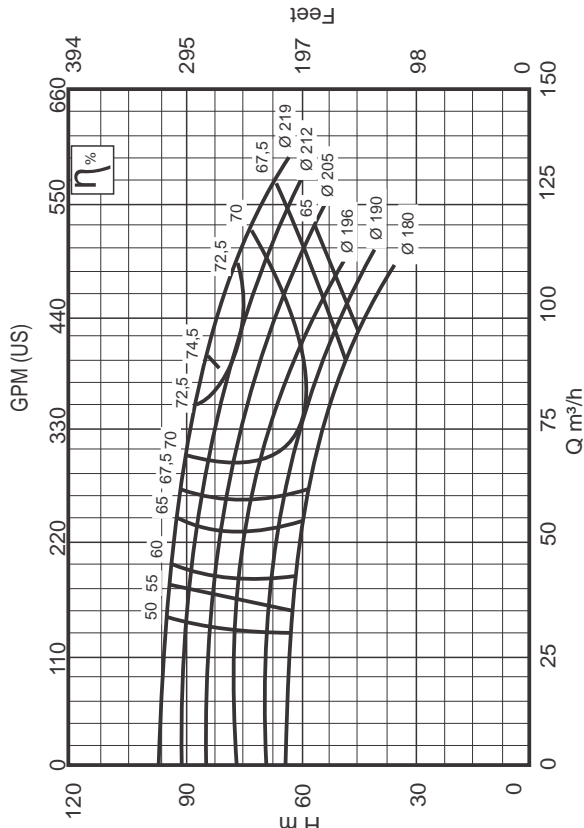

Impeller Ø Max. 219 mm
Impeller Ø Min. 180 mm
Impeller of Width 11 mm
Viscosity $\mu = 1\text{cP}$

Suction Flange 80 mm
Pressure Flange 50 mm
Specific Weight $\gamma = 1\text{kgf/dm}^3$

INI 50-160

3500 rpm

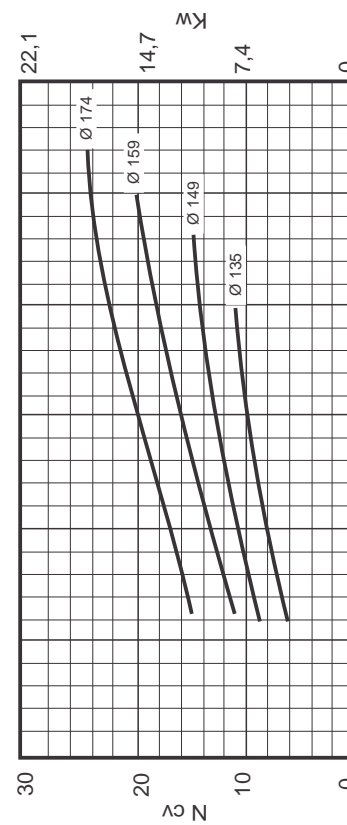
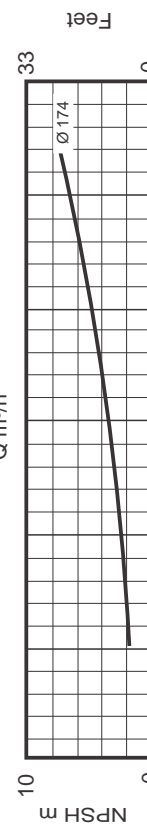
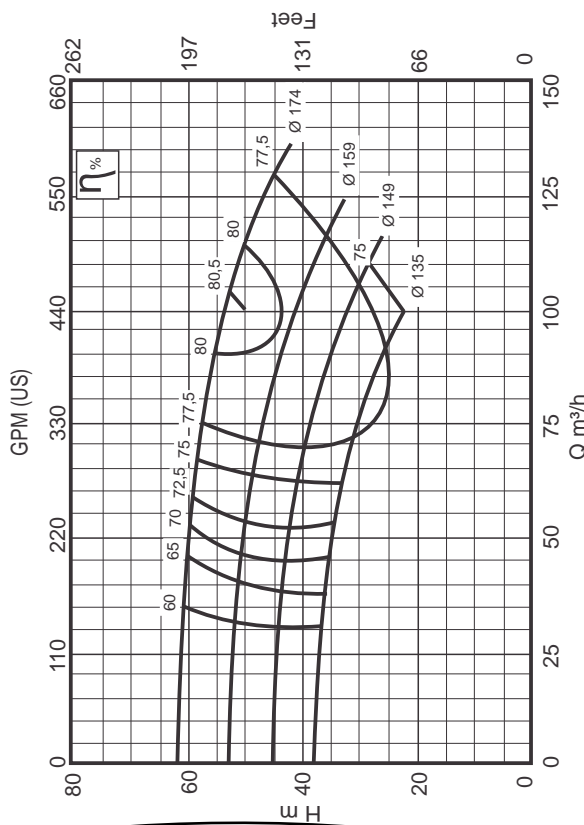

Impeller Ø Max. 174 mm
Impeller Ø Min. 135 mm
Impeller of Width 16 mm
Viscosity $\mu = 1\text{cP}$

Suction Flange 80 mm
Pressure Flange 50 mm
Specific Weight $\gamma = 1\text{kgf/dm}^3$

INI 50-315

3500 rpm

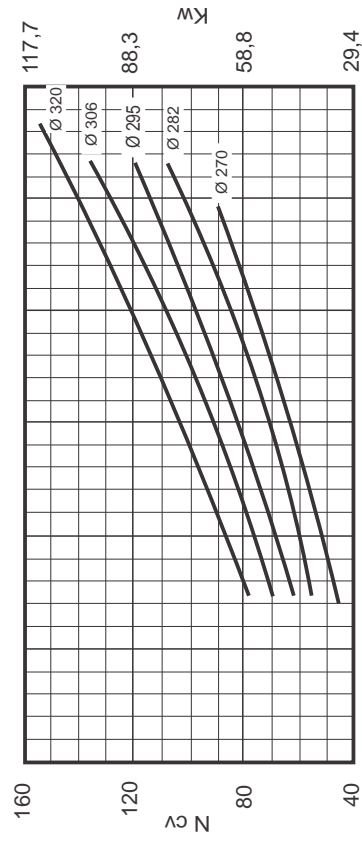
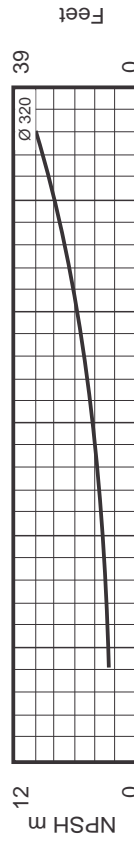
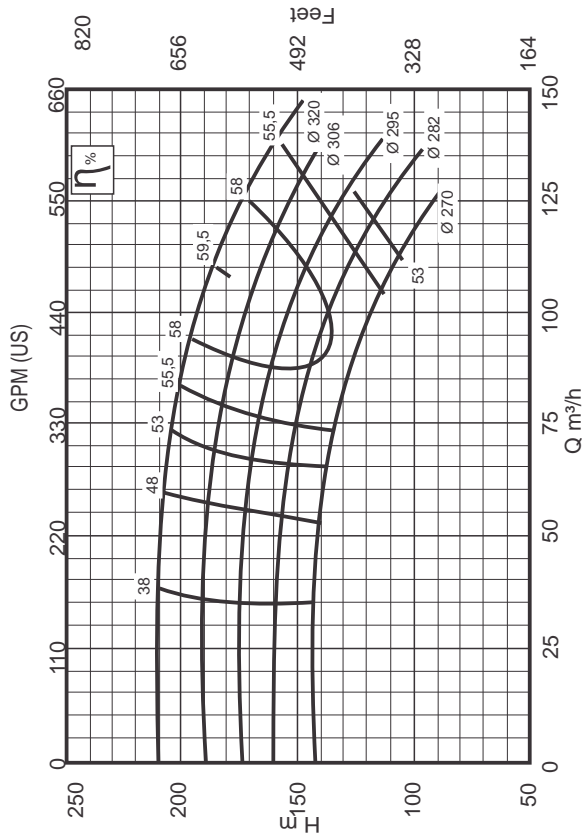

Impeller Ø Max. 320 mm
Impeller Ø Min. 270 mm
Impeller of Width 9 mm
Viscosity $\mu = 1\text{cP}$

Suction Flange 80 mm
Pressure Flange 50 mm
Specific Weight $\gamma = 1\text{kgf/dm}^3$

INI 50-250

3500 rpm

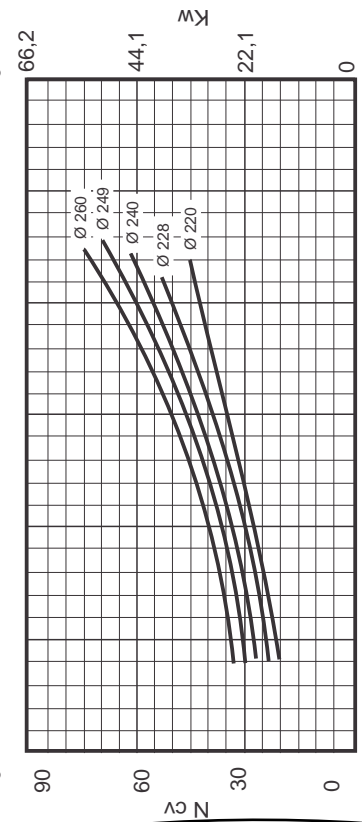
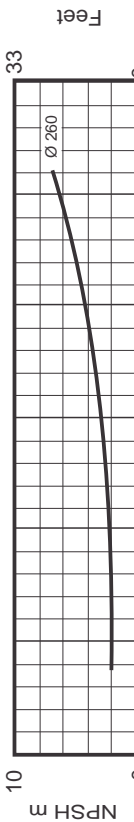
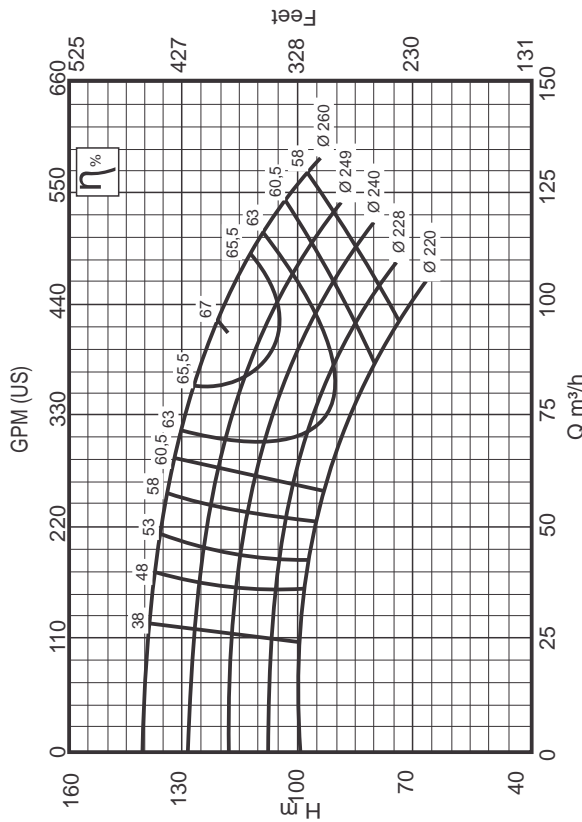

Impeller Ø Max. 260 mm
Impeller Ø Min. 220 mm
Impeller of Width 12 mm
Viscosity $\mu = 1\text{cP}$

Suction Flange 80 mm
Pressure Flange 50 mm
Specific Weight $\gamma = 1\text{kgf/dm}^3$

3500 rpm

INI 65-250

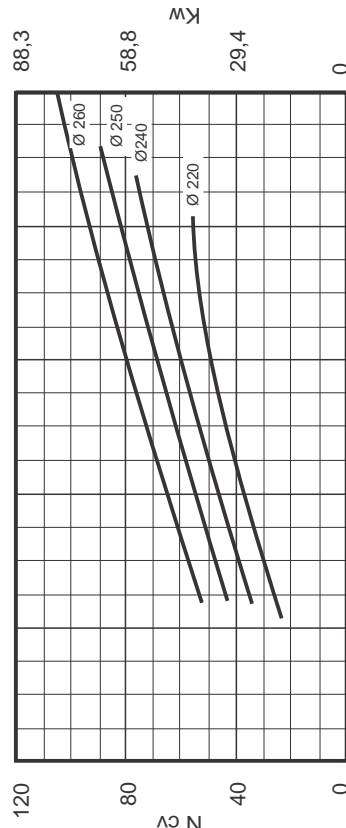
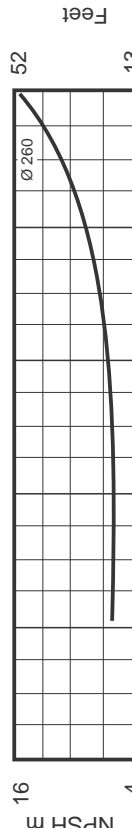
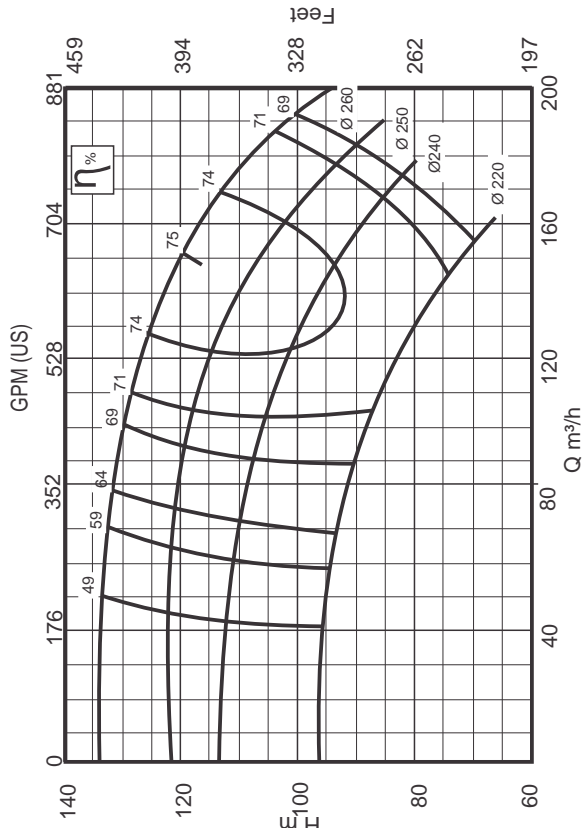

Impeller Ø Max. 260 mm
Impeller Ø Min. 220 mm
Impeller of Width 13 mm
Viscosity $\mu = 1\text{cP}$

Suction Flange 100 mm
Pressure Flange 65 mm
Specific Weight $\gamma = 1\text{kgf/dm}^3$

3500 rpm

INI 65-200

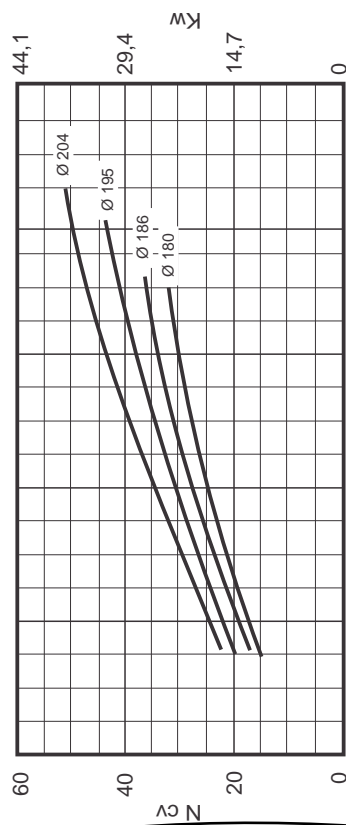
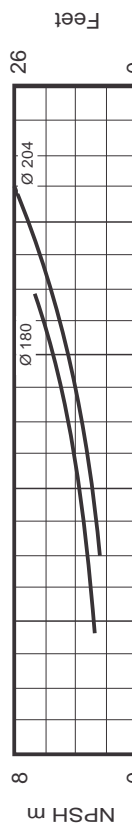
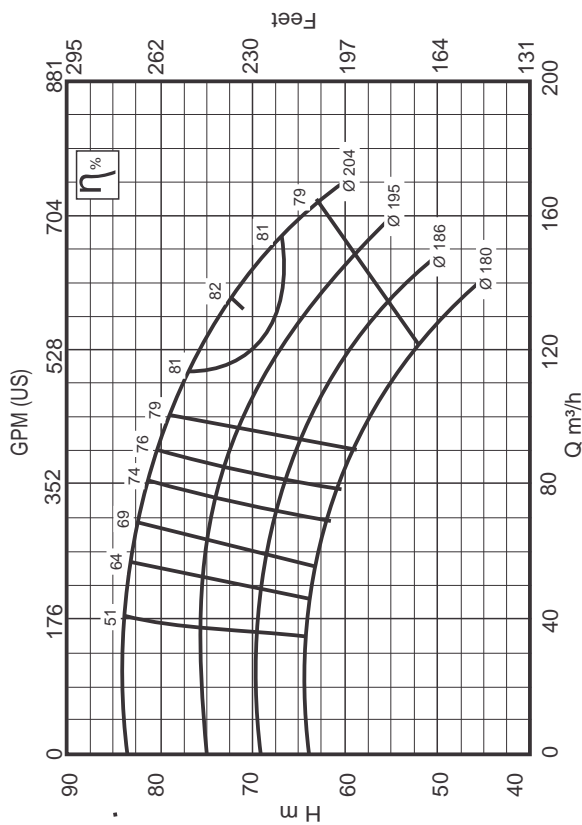

Impeller Ø Max. 204 mm
Impeller Ø Min. 180 mm
Impeller of Width 17 mm
Viscosity $\mu = 1\text{cP}$

Suction Flange 100 mm
Pressure Flange 65 mm
Specific Weight $\gamma = 1\text{kgf/dm}^3$

INI 80-200

3500 rpm

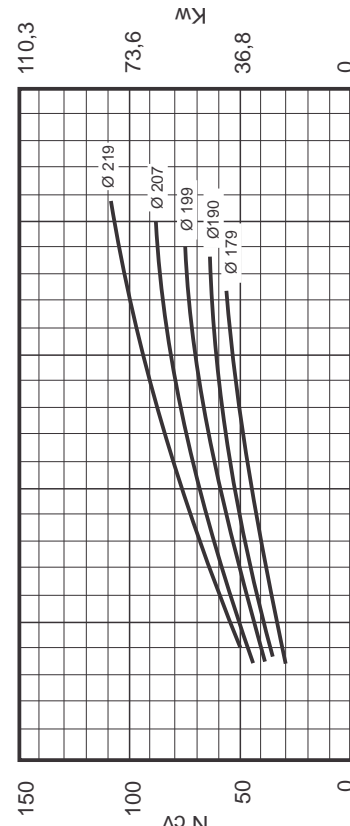
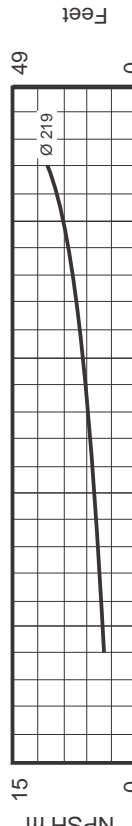
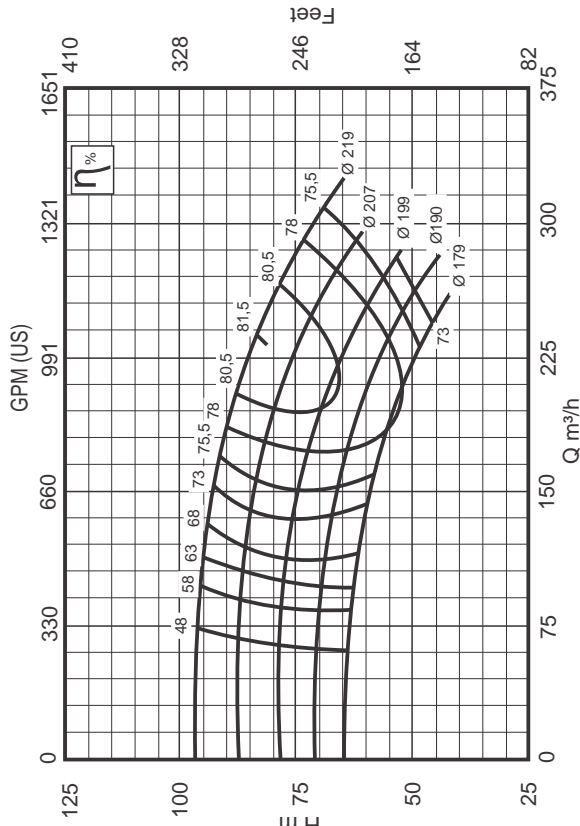

Suction Flange 125 mm
Pressure Flange 80 mm
Specific Weight $\gamma = 1 \text{ kgf/dm}^3$

Impeller Ø Max. 219 mm
Impeller Ø Min. 179 mm
Impeller of Width 23 mm
Viscosity $\mu = 1 \text{ cP}$

INI 80-160

3500 rpm

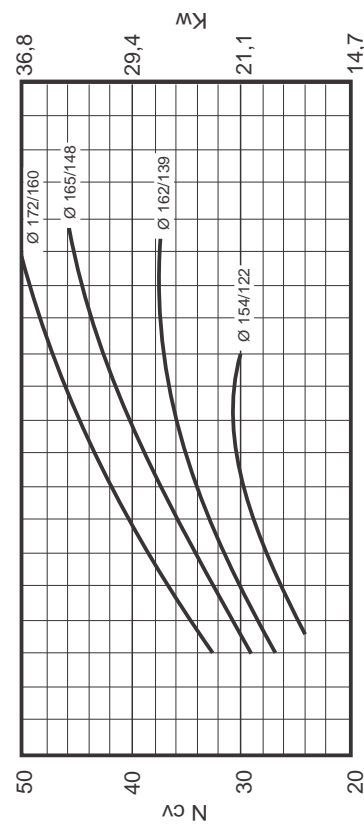
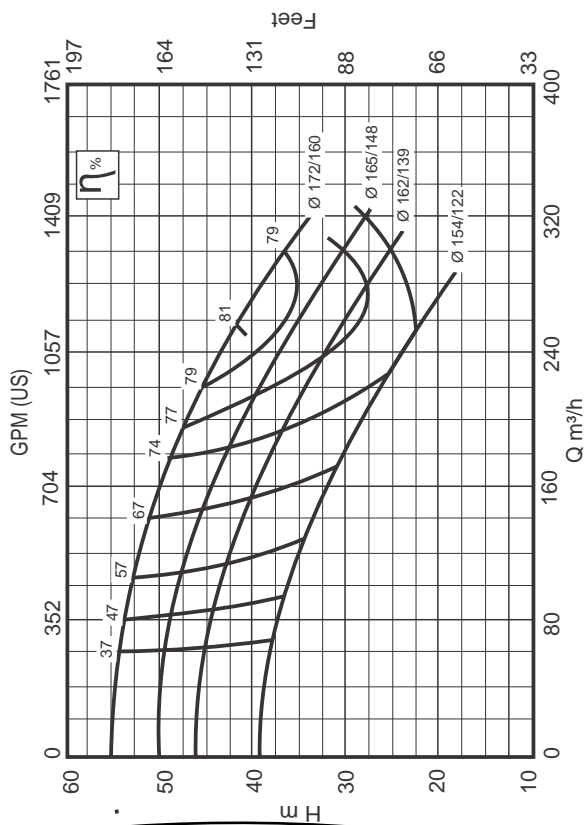

Suction Flange 125 mm
Pressure Flange 80 mm
Specific Weight $\gamma = 1 \text{ kgf/dm}^3$

Impeller Ø Max. 172/160 mm
Impeller Ø Min. 154/122 mm
Impeller of Width 31 mm
Viscosity $\mu = 1 \text{ cP}$

INI 100-160

3500 rpm

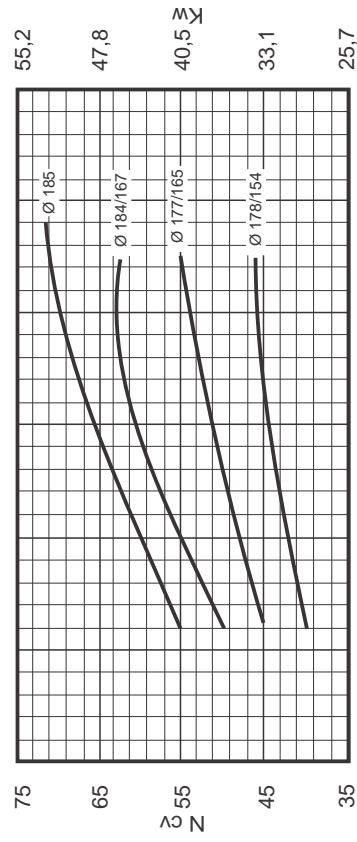
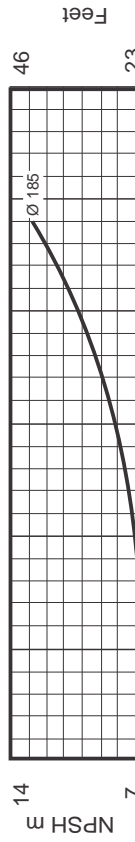
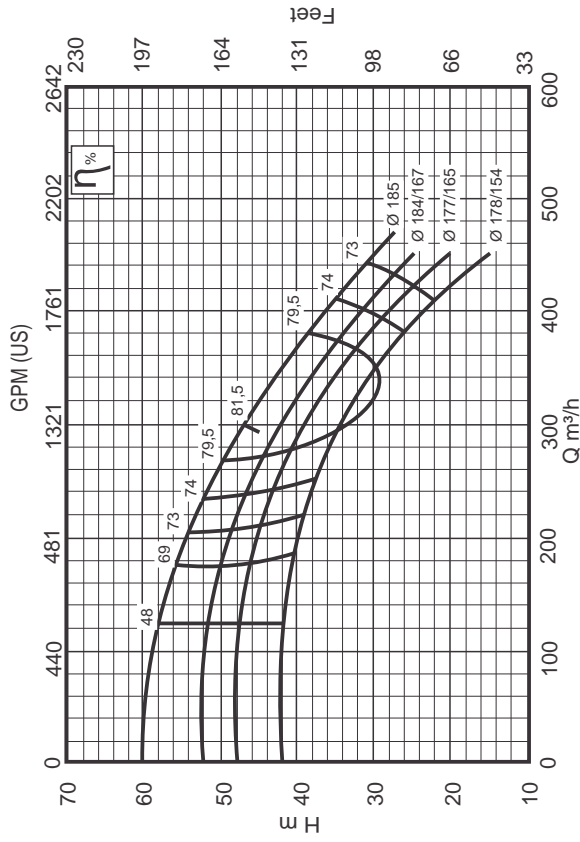

INI 80-250

3500 rpm

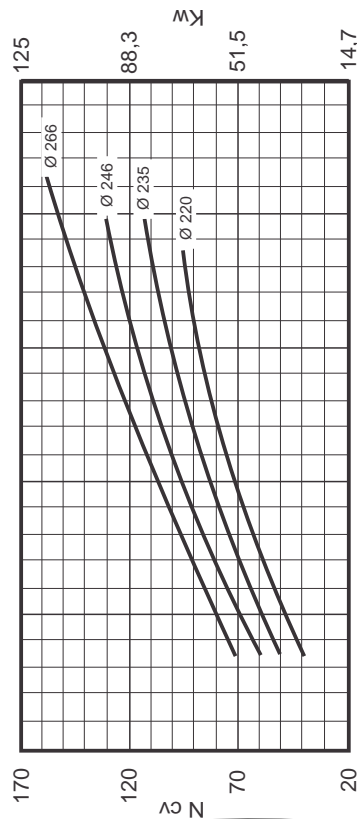
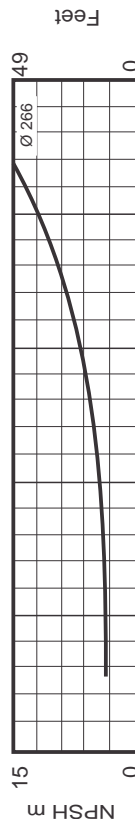
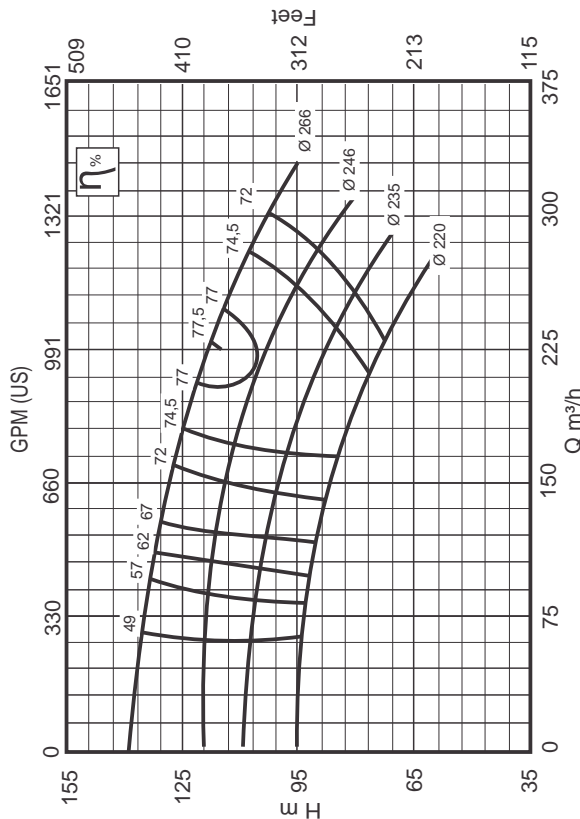

Impeller Ø Max. 185 mm
Impeller Ø Min. 178/154 mm
Impeller of Width 36 mm
Viscosity $\mu = 1\text{cP}$

Suction Flange 125 mm
Pressure Flange 100 mm
Specific Weight $\gamma = 1\text{kgf/dm}^3$

Impeller Ø Max. 266 mm
Impeller Ø Min. 220 mm
Impeller of Width 19 mm
Viscosity $\mu = 1\text{cP}$

Suction Flange 125 mm
Pressure Flange 80 mm
Specific Weight $\gamma = 1\text{kgf/dm}^3$

INI 32-125 1750 rpm

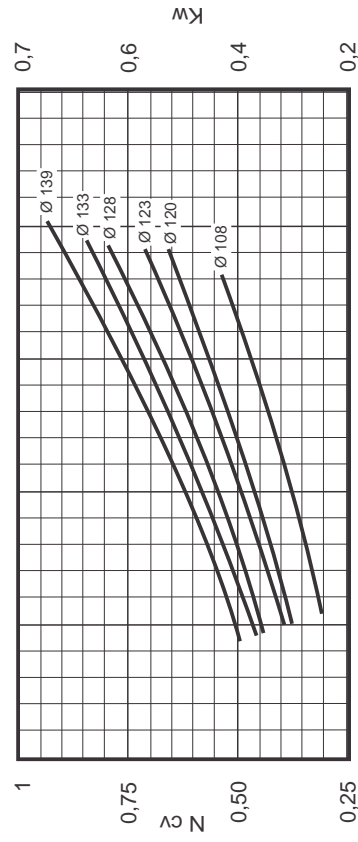
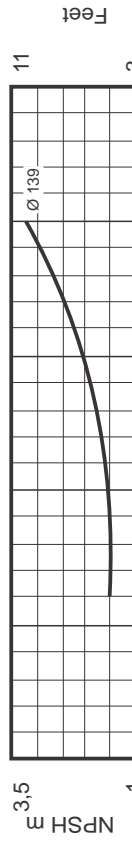
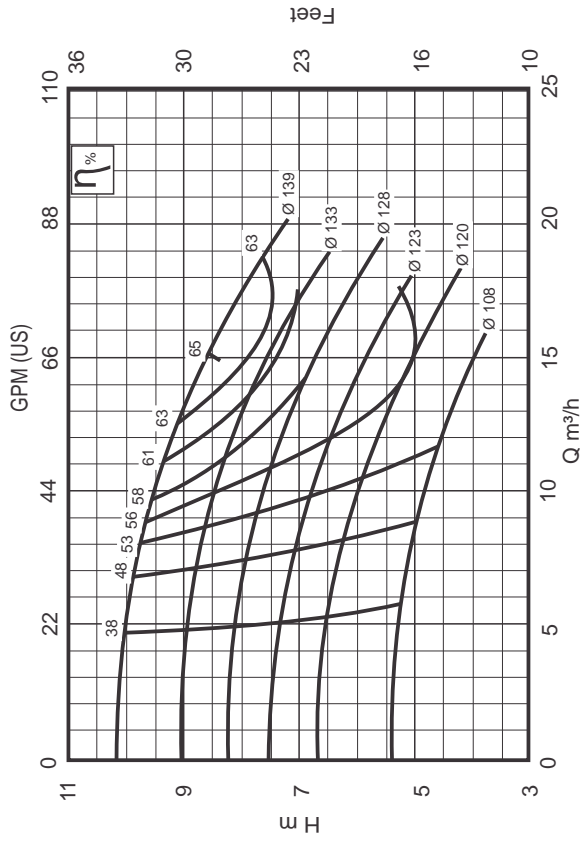

Suction Flange 50mm
Pressure Flange 32 mm
Specific Weight $\gamma = 1 \text{ kgf/dm}^3$

Impeller Ø Max. 139 mm
Impeller Ø Min. 108 mm
Impeller of Width 9 mm
Viscosity $\mu = 1 \text{ cP}$

INI 100-200 3500 rpm

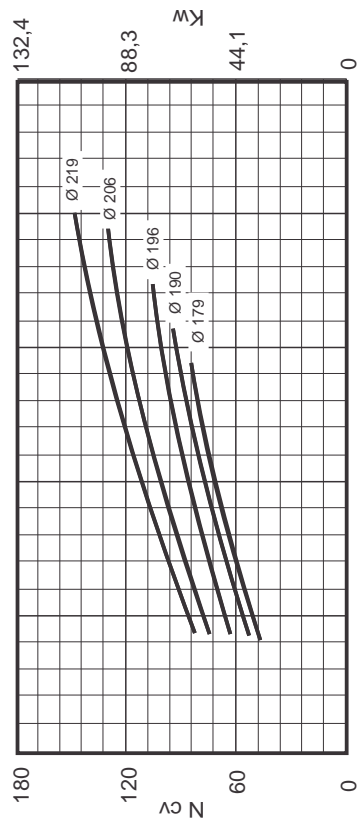
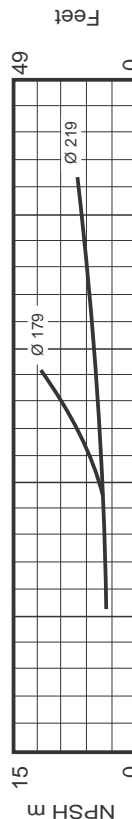
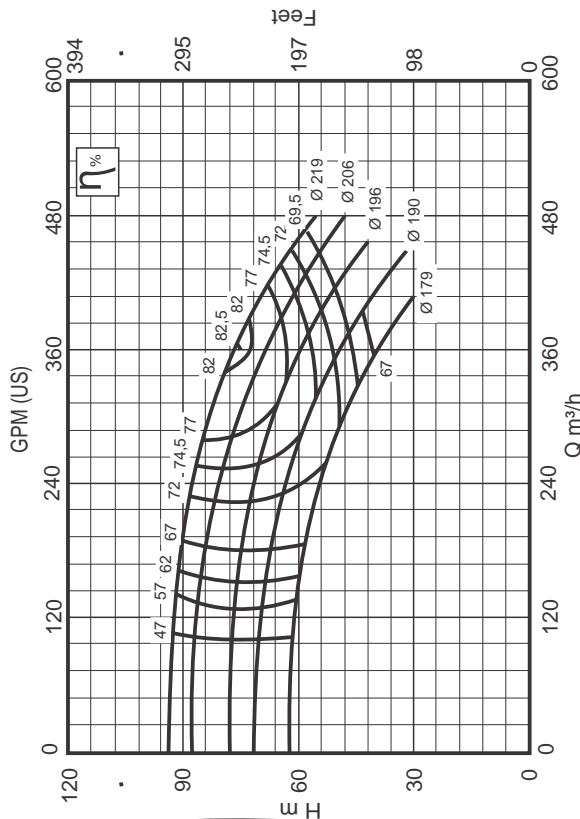

Suction Flange 125 mm
Pressure Flange 100 mm
Specific Weight $\gamma = 1 \text{ kgf/dm}^3$

Impeller Ø Max. 219 mm
Impeller Ø Min. 179 mm
Impeller of Width 32 mm
Viscosity $\mu = 1 \text{ cP}$

INI 32-160 1750rpm

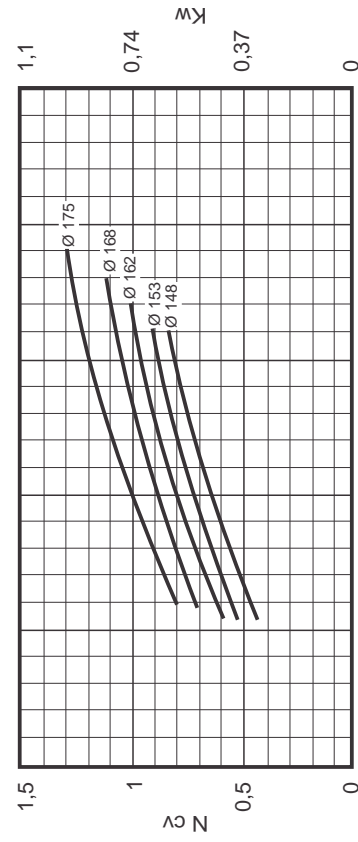
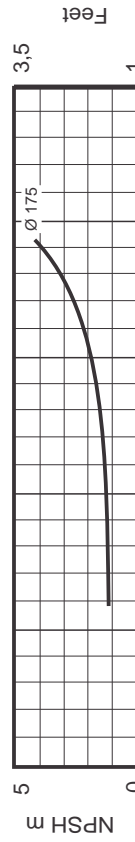
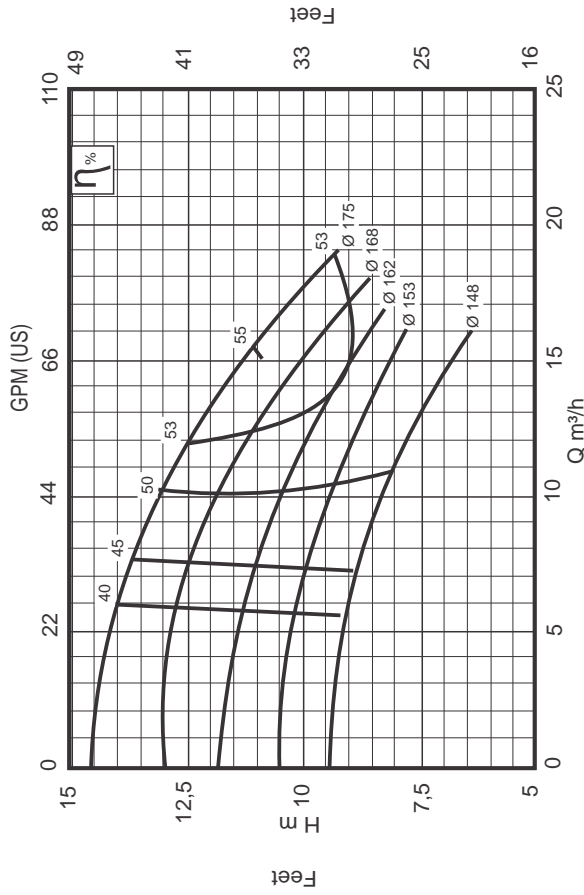

Suction Flange 50 mm
Pressure Flange 32 mm
Specific Weight $\gamma = 1 \text{ kgf/dm}^3$

Impeller Ø Max. 176 mm
Impeller Ø Min. 148 mm
Impeller of Width 5 mm
Viscosity $\mu = 1 \text{ cP}$

INI 32-125.1 1750 rpm

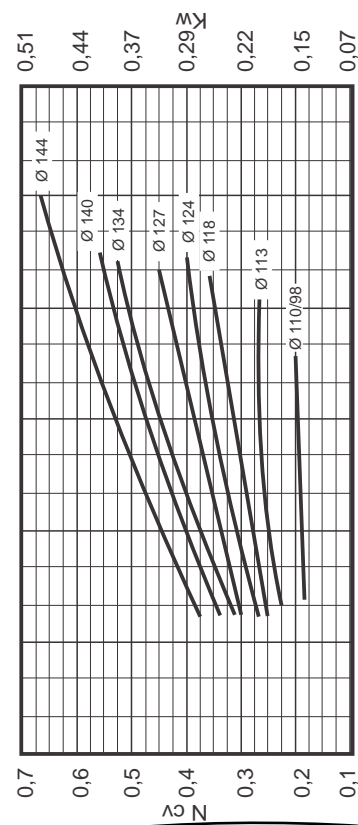
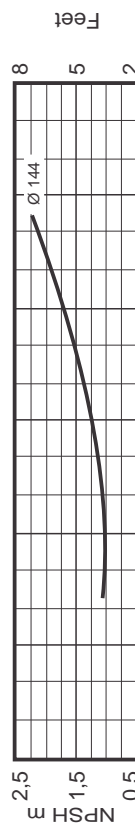
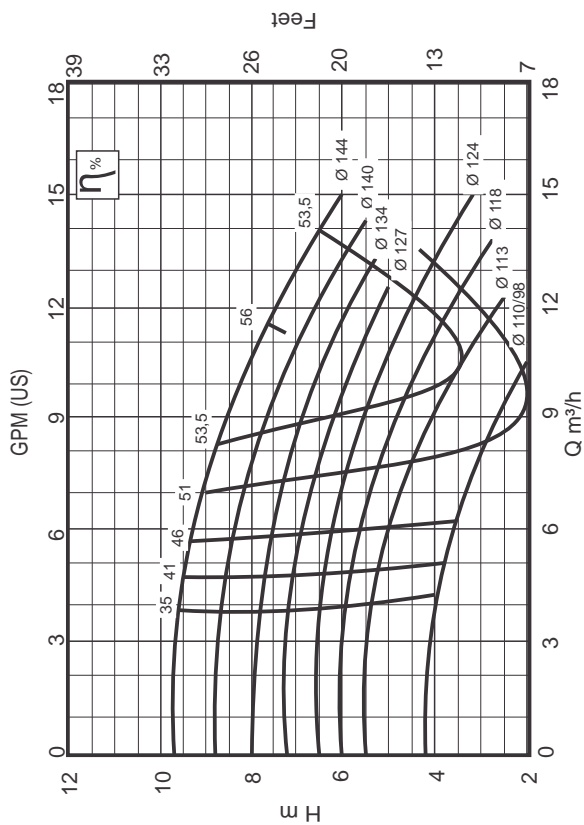

Suction Flange 50 mm
Pressure Flange 32 mm
Specific Weight $\gamma = 1 \text{ kgf/dm}^3$

Impeller Ø Max. 144 mm
Impeller Ø Min. 110/98 mm
Viscosity $\mu = 1 \text{ cP}$

1750 rpm

INI 32-200

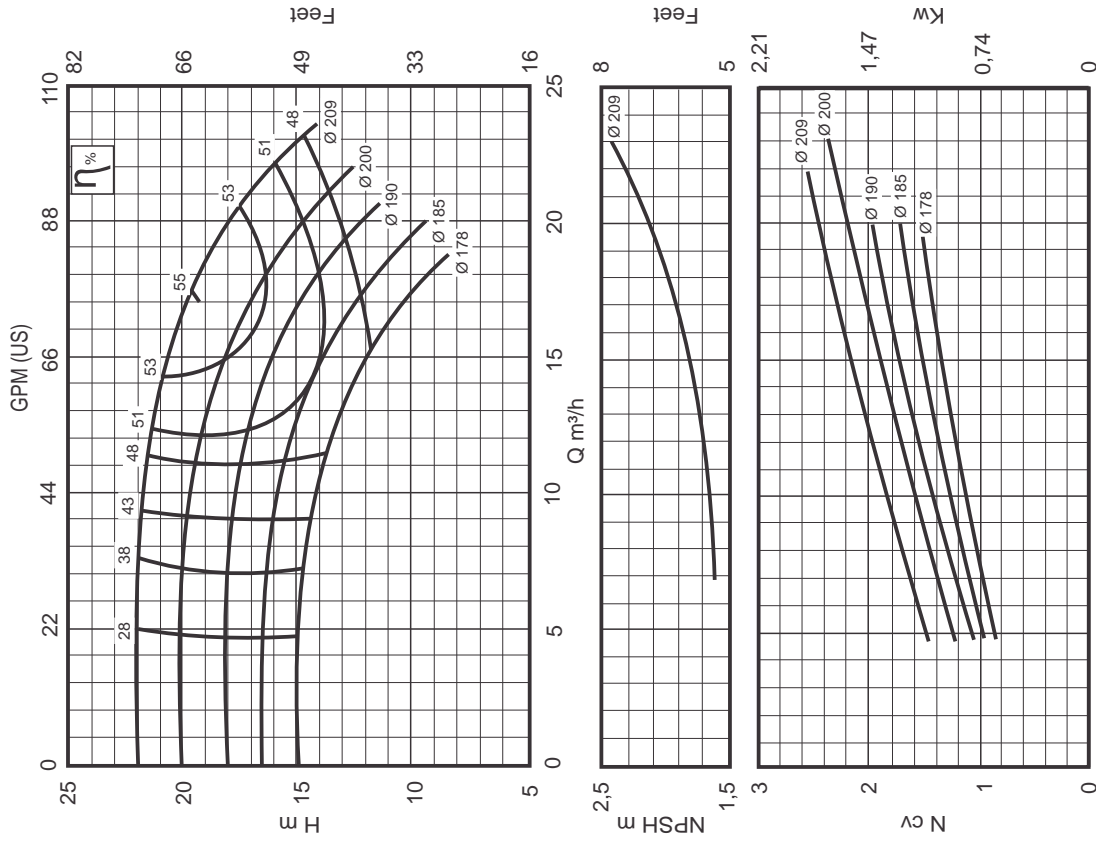

Suction Flange 50 mm
Pressure Flange 32 mm
Specific Weight $\gamma = 1 \text{ kgf/dm}^3$

Impeller \varnothing Max. 209 mm
Impeller \varnothing Min. 178 mm
Impeller of Width 6 mm
Viscosity $\mu = 1 \text{ cP}$

1750rpm

INI 32-160.1

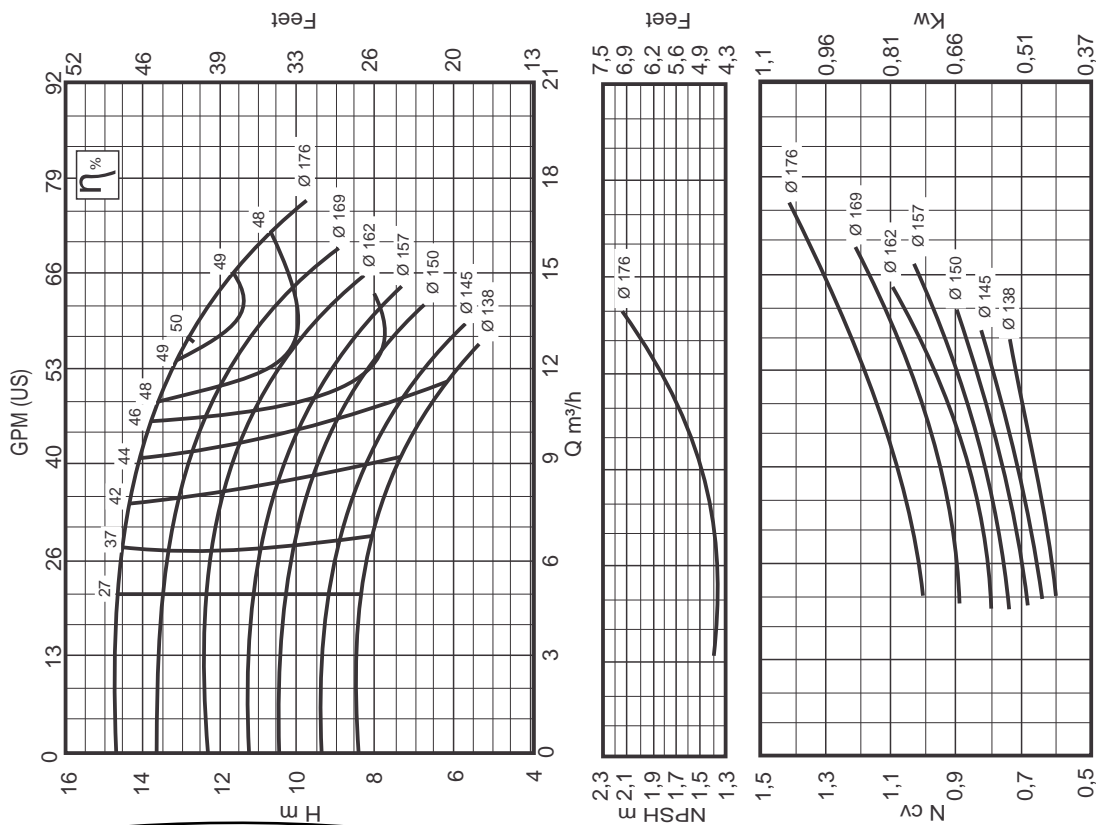

Suction Flange 50 mm
Pressure Flange 32 mm
Specific Weight $\gamma = 1 \text{ kgf/dm}^3$

Impeller \varnothing Max. 176 mm
Impeller \varnothing Min. 138 mm
Impeller of Width 6 mm
Viscosity $\mu = 1 \text{ cP}$

INI 32-250

1750rpm

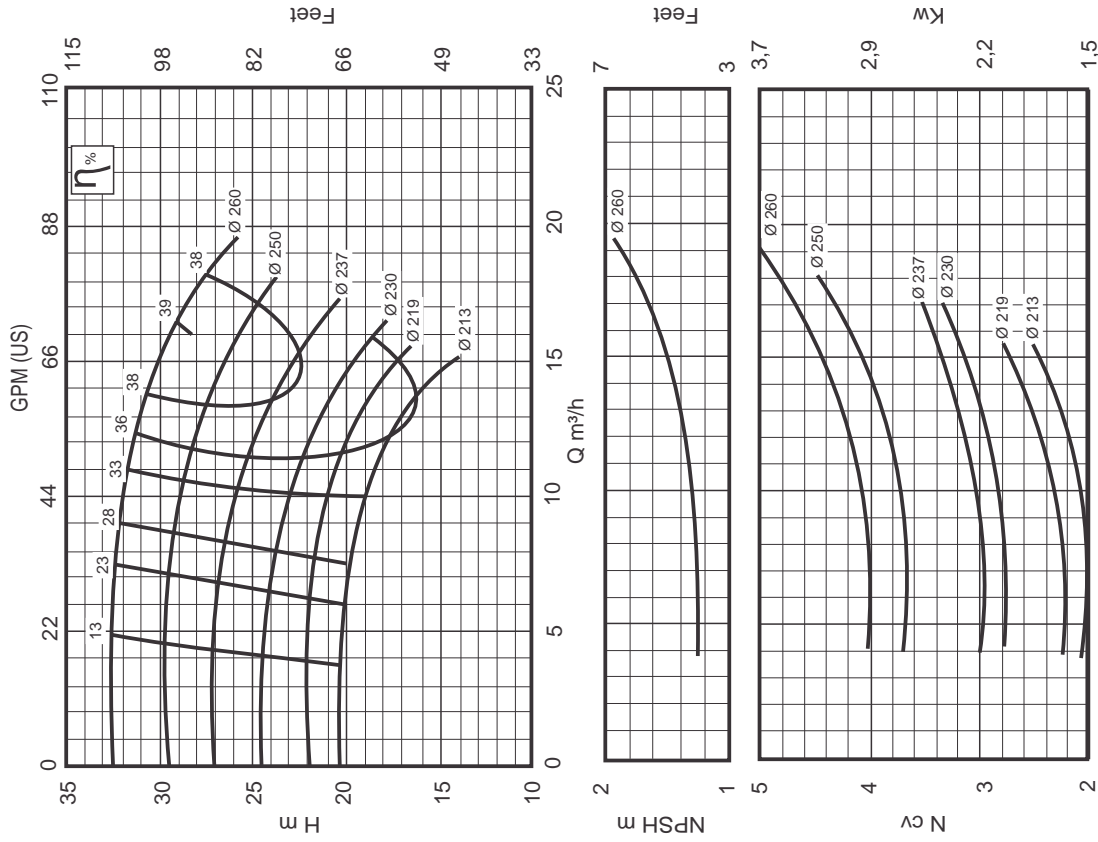

Suction Flange 50 mm
Pressure Flange 32 mm
Specific Weight $\gamma = 1 \text{ kgf/dm}^3$

Impeller Ø Max. 260 mm
Impeller Ø Min. 213 mm
Impeller of Width 8 mm
Viscosity $\mu = 1 \text{ cP}$

INI 32-200.1

1750rpm

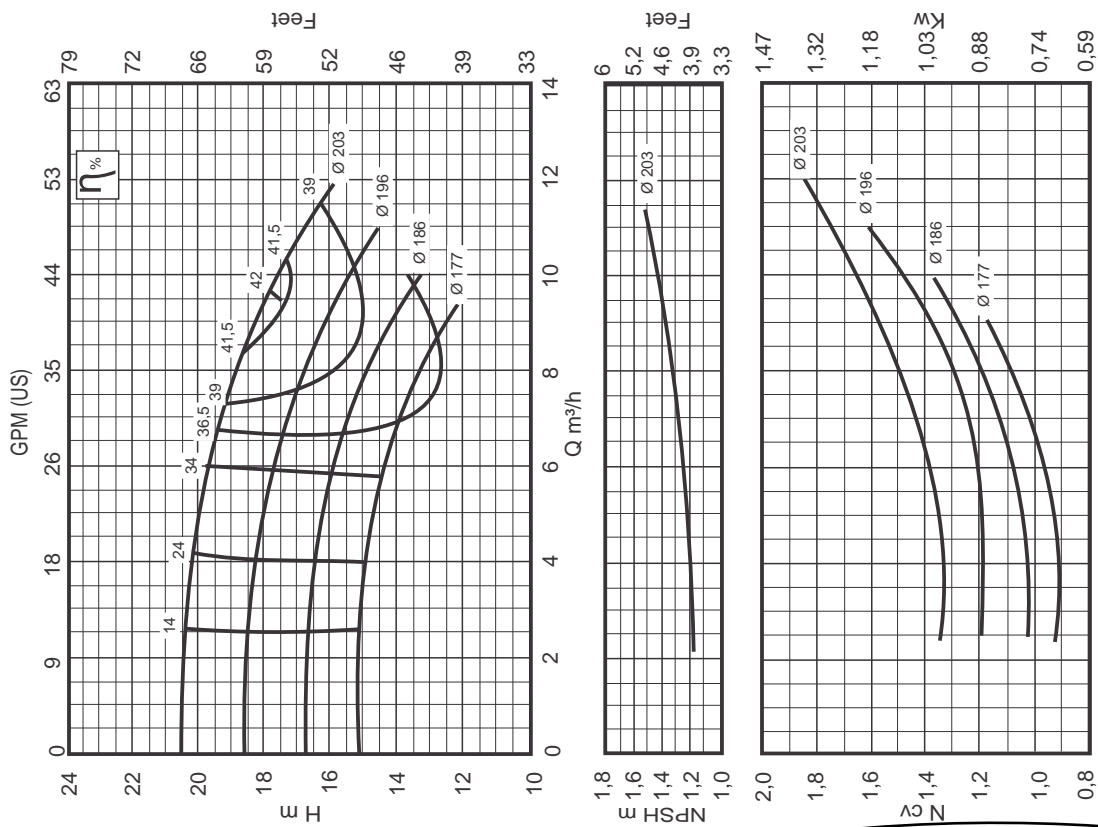

Suction Flange 50 mm
Pressure Flange 32 mm
Specific Weight $\gamma = 1 \text{ kgf/dm}^3$

Impeller Ø Max. 203 mm
Impeller Ø Min. 177 mm
Viscosity $\mu = 1 \text{ cP}$

1750 rpm

INI 40-125

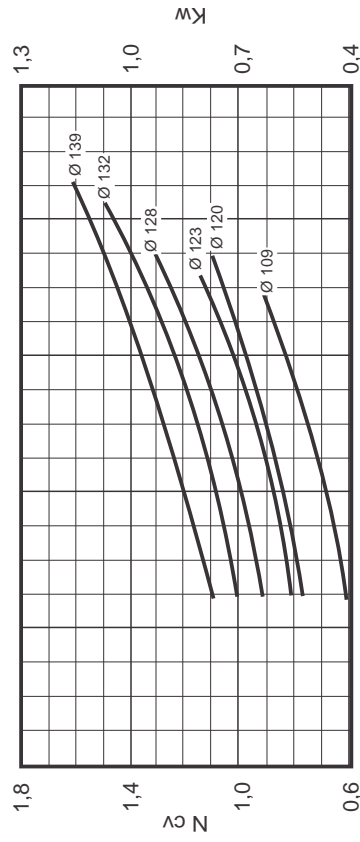
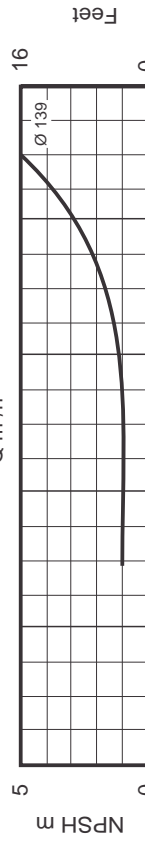
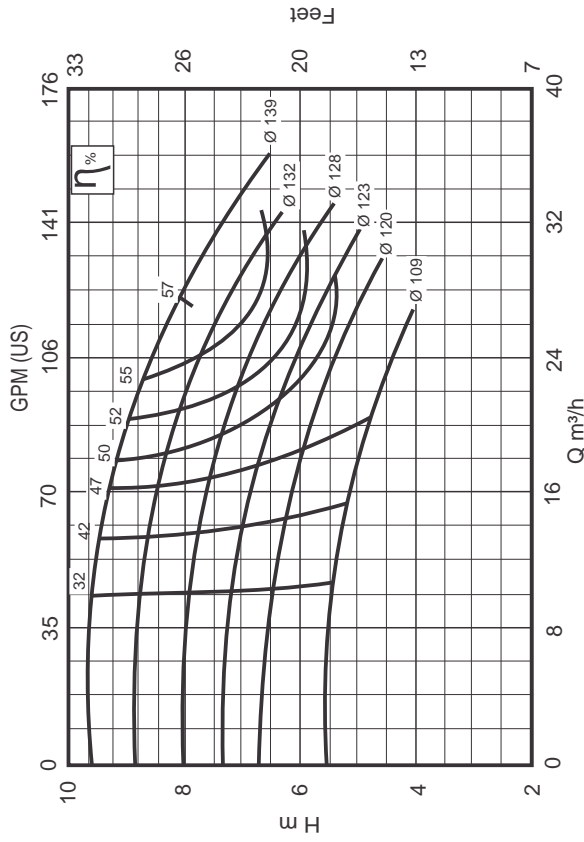

Suction Flange 65 mm
Pressure Flange 40 mm
Specific Weight $\gamma = 1 \text{ kgf/dm}^3$

Impeller Ø Max. 139 mm
Impeller Ø Min. 109 mm
Impeller Width 14 mm
Viscosity $\mu = 1 \text{ cP}$

1750rpm

INI 32-250.1

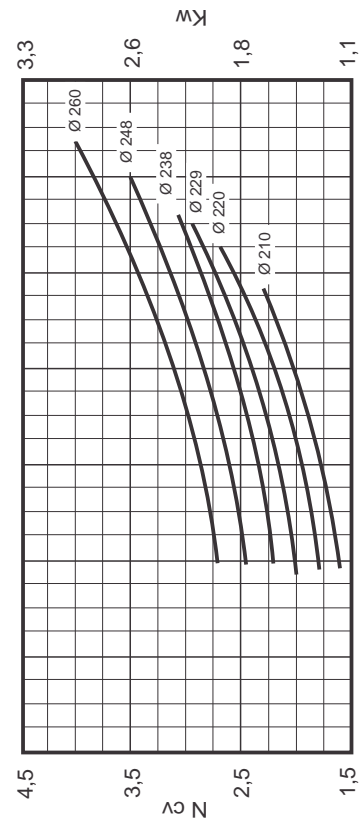
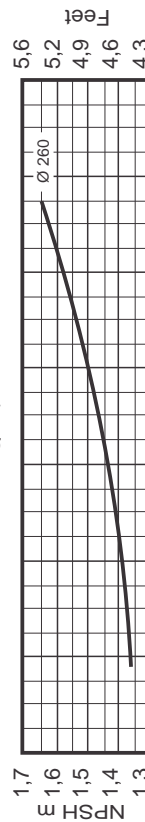
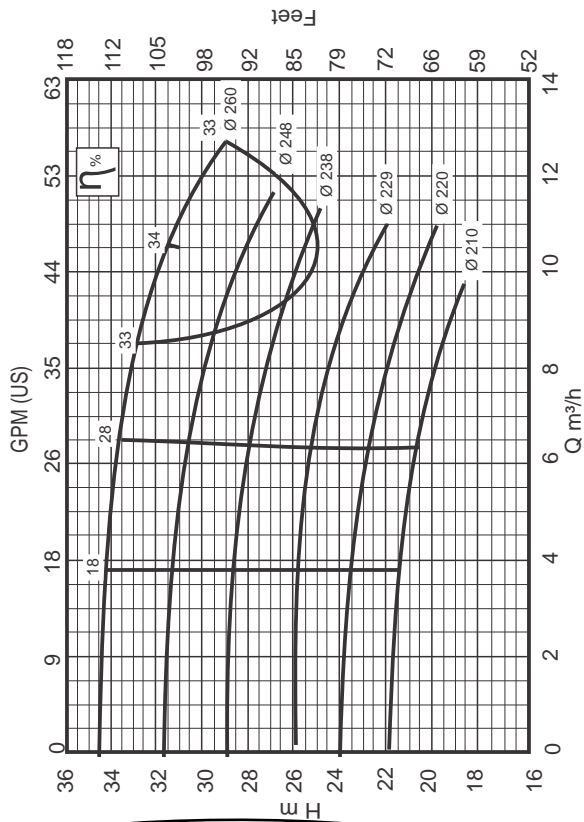

Suction Flange 50 mm
Pressure Flange 32 mm
Specific Weight $\gamma = 1 \text{ kgf/dm}^3$

Impeller Ø Max. 260 mm
Impeller Ø Min. 210 mm
Viscosity $\mu = 1 \text{ cP}$

INI 40-200 1750 rpm

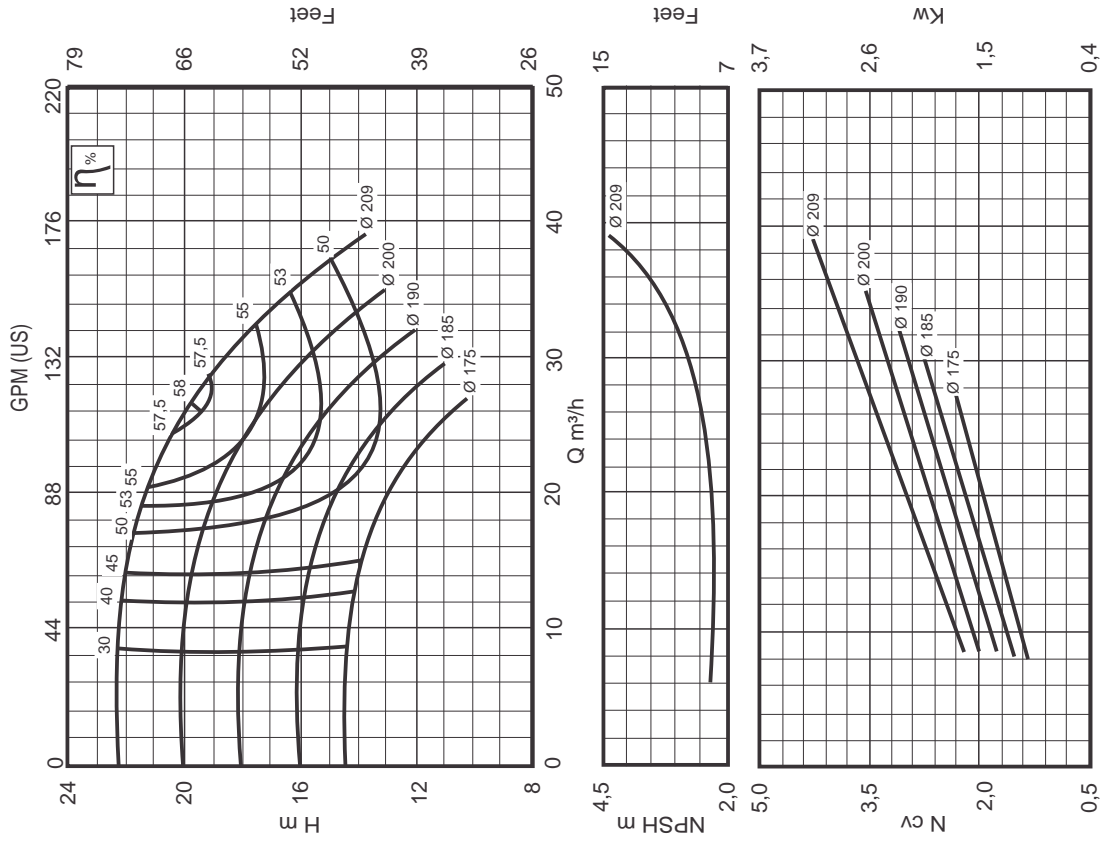

Suction Flange 65 mm
 Pressure Flange 40 mm
 Specific Weight $\gamma = 1 \text{ kgf/dm}^3$

Impeller \varnothing Max. 209 mm
 Impeller \varnothing Min. 175 mm
 Impeller of Width 9 mm
 Viscosity $\mu = 1 \text{ cP}$

INI 40-160 1750 rpm

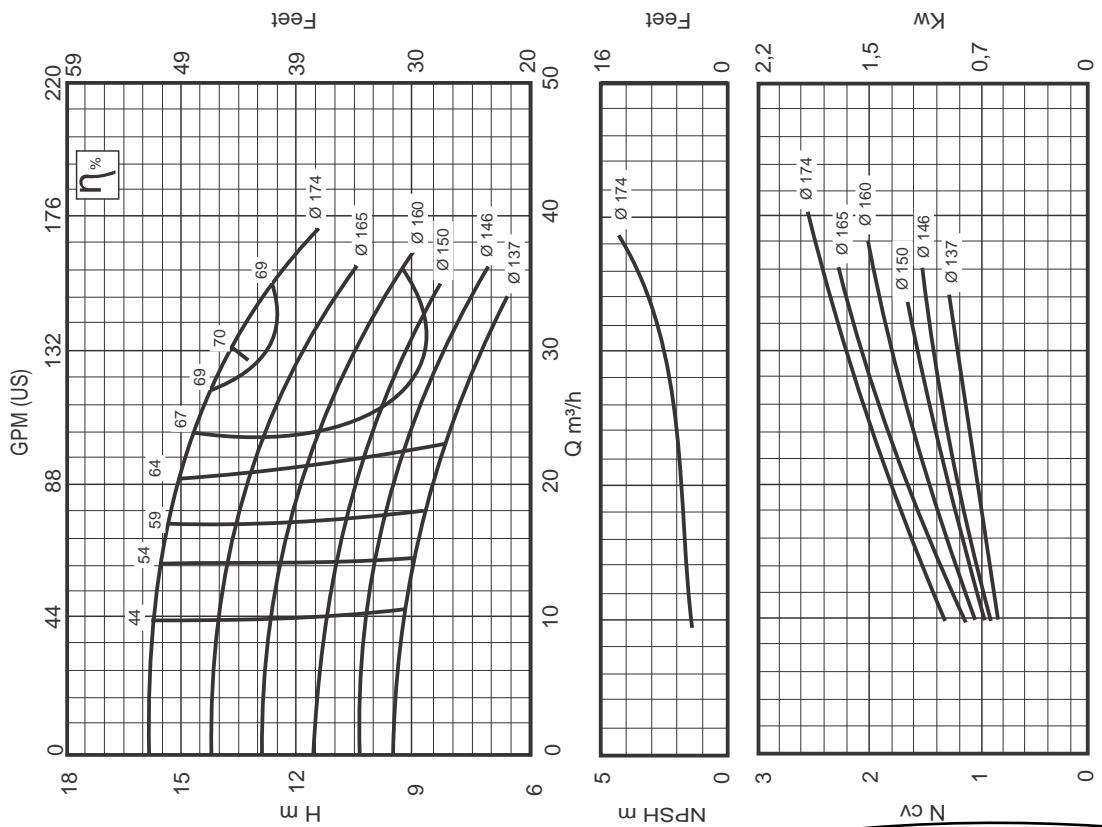

Suction Flange 65 mm
 Pressure Flange 40 mm
 Specific Weight $\gamma = 1 \text{ kgf/dm}^3$

Impeller \varnothing Max. 174 mm
 Impeller \varnothing Min. 137 mm
 Impeller of Width 12 mm
 Viscosity $\mu = 1 \text{ cP}$

INI 40-315

1750 rpm

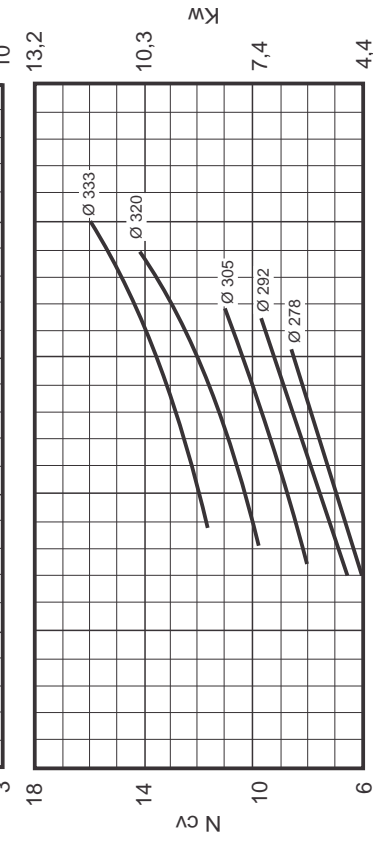
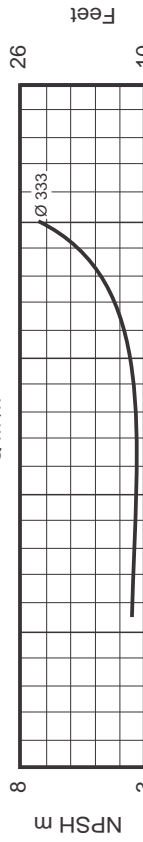
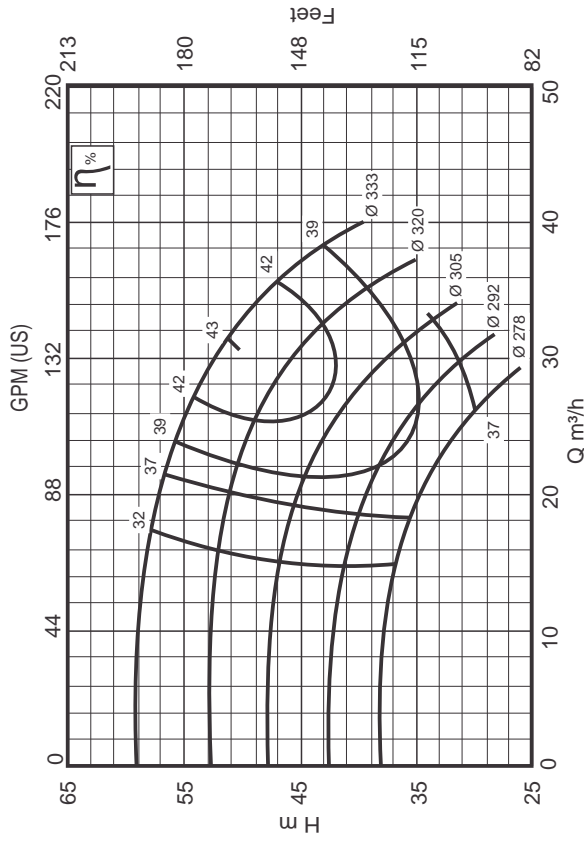

Suction Flange 65 mm
Pressure Flange 40 mm
Specific Weight $\gamma = 1 \text{ kgf/dm}^3$

Impeller Ø Max. 333 mm
Impeller Ø Min. 278 mm
Impeller of Width 9 mm
Viscosity $\mu = 1 \text{ cP}$

INI 40-250

1750 rpm

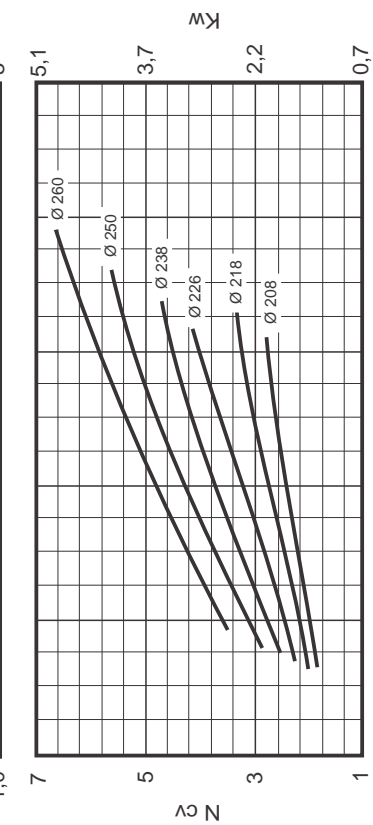
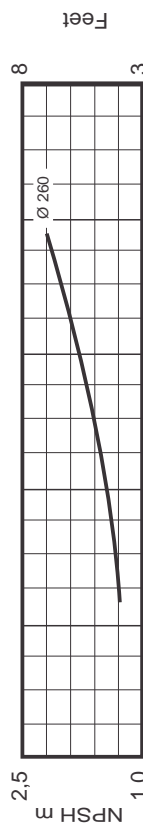
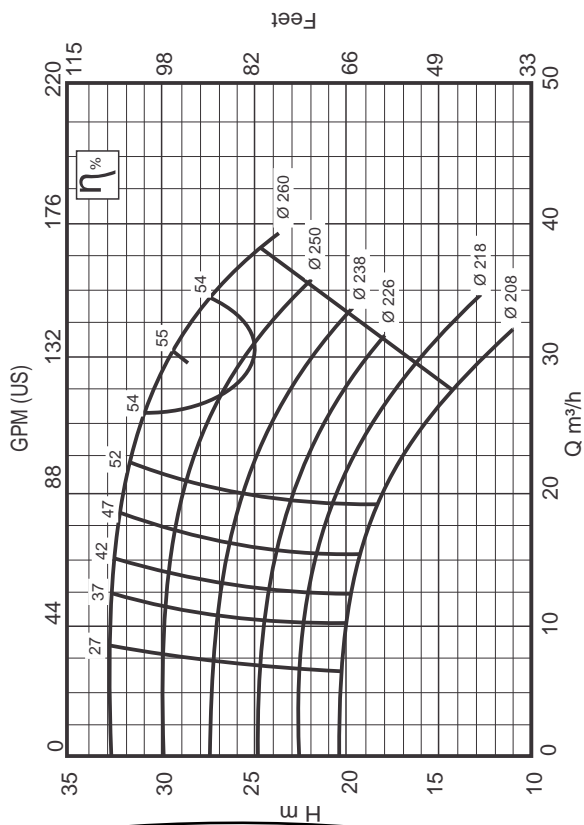

Suction Flange 65 mm
Pressure Flange 40 mm
Specific Weight $\gamma = 1 \text{ kgf/dm}^3$

Impeller Ø Max. 260 mm
Impeller Ø Min. 208 mm
Impeller of Width 8 mm
Viscosity $\mu = 1 \text{ cP}$

INI 50-160 1750 rpm

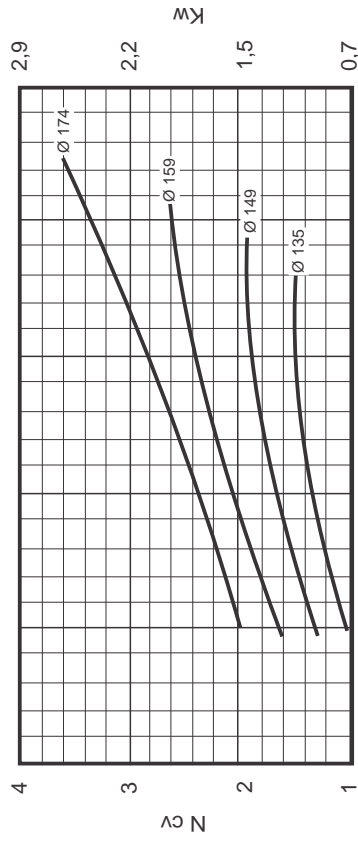
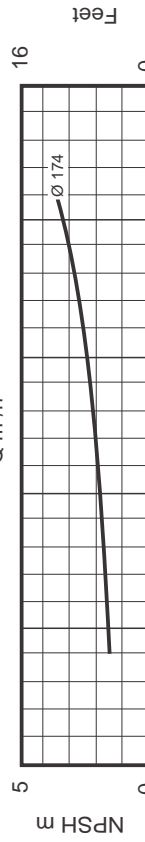
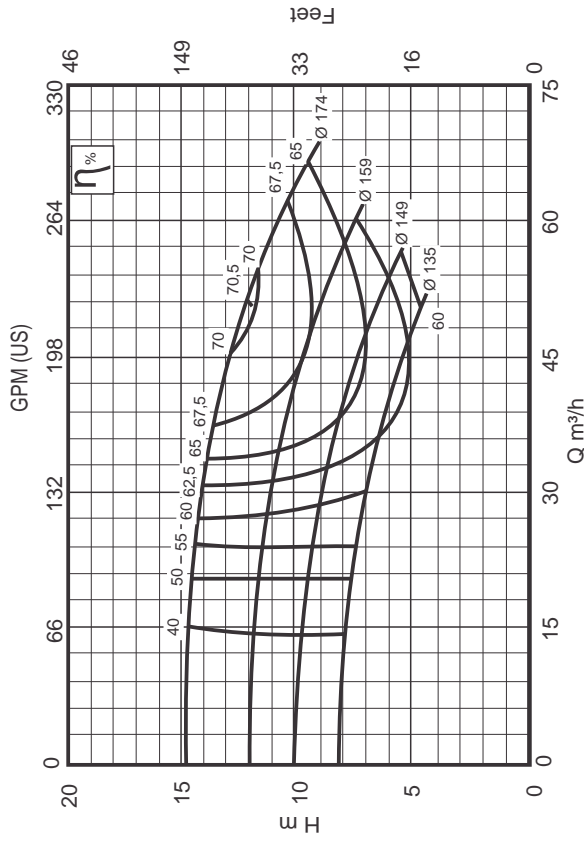

Suction Flange 80 mm
Pressure Flange 50 mm
Specific Weight $\gamma = 1 \text{ kgf/dm}^3$

Impeller Ø Max. 174 mm
Impeller Ø Min. 135 mm
Impeller of Width 16 mm
Viscosity $\mu = 1 \text{ cP}$

INI 50-125 1750 rpm

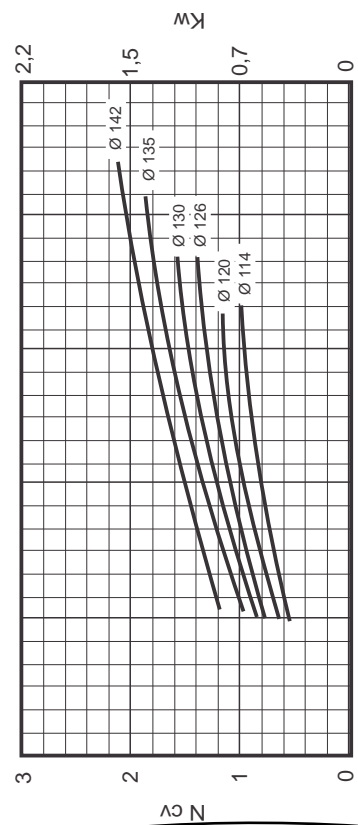
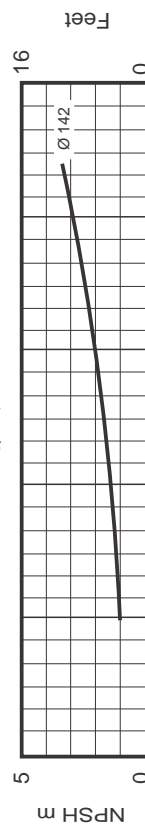
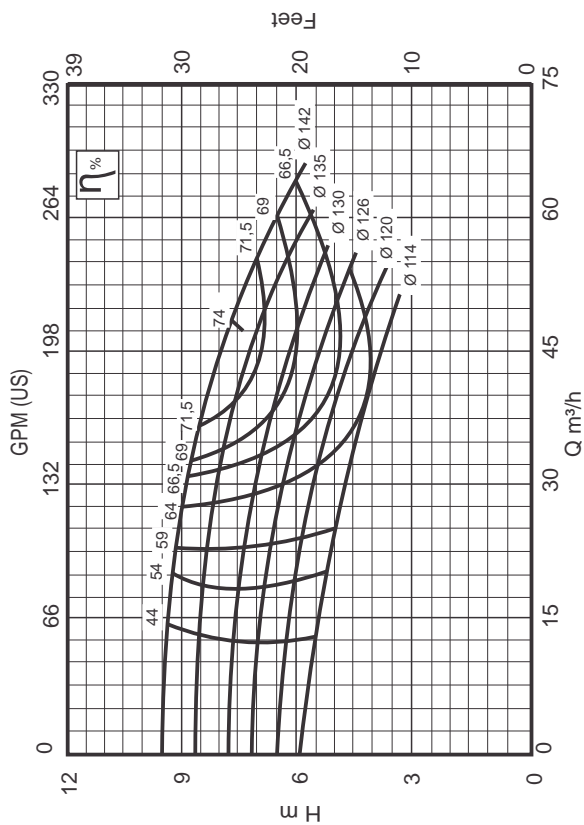

Suction Flange 80 mm
Pressure Flange 50 mm
Specific Weight $\gamma = 1 \text{ kgf/dm}^3$

Impeller Ø Max. 142 mm
Impeller Ø Min. 114 mm
Impeller of Width 20 mm
Viscosity $\mu = 1 \text{ cP}$

INI 65-125 1750 rpm

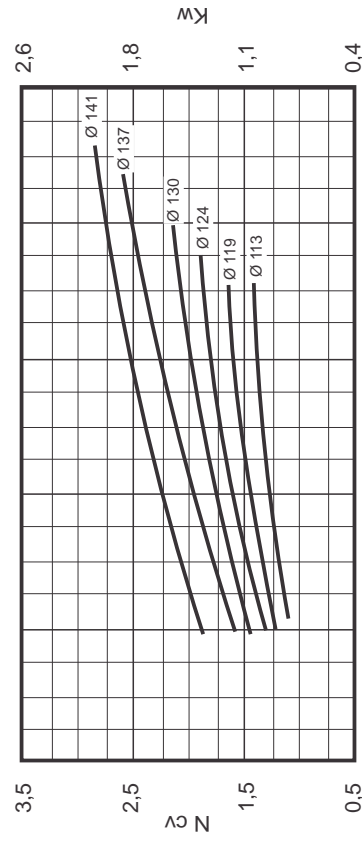
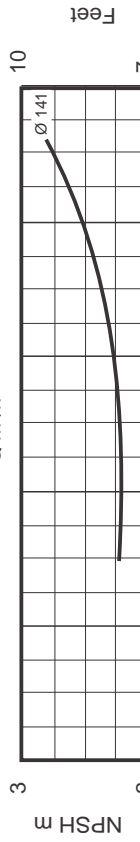
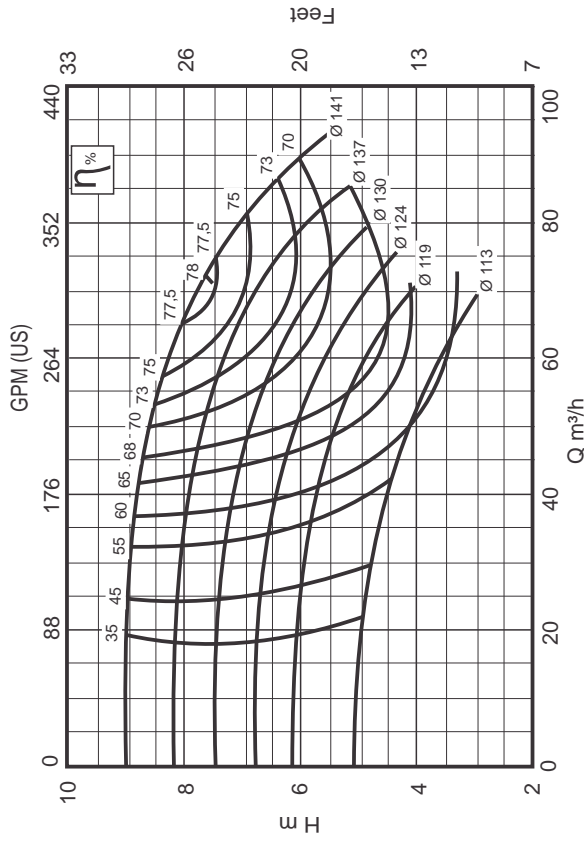

Impeller Ø Max. 141 mm
Impeller Ø Min. 113 mm
Impeller of Width 25 mm
Viscosity $\mu = 1\text{cP}$

Suction Flange 100 mm
Pressure Flange 65 mm
Specific Weight $\gamma = 1\text{kgf/dm}^3$

INI 50-315 1750 rpm

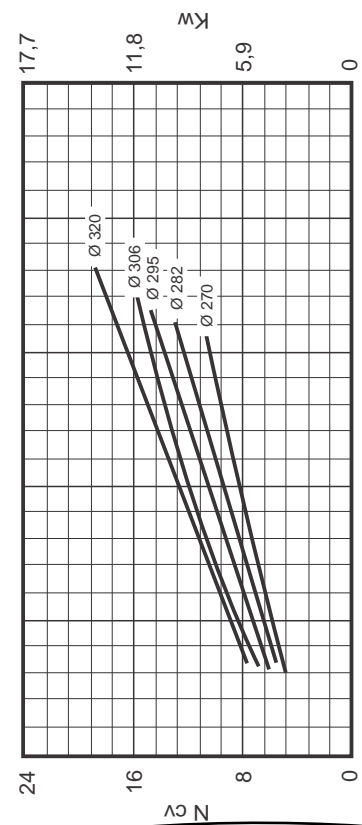
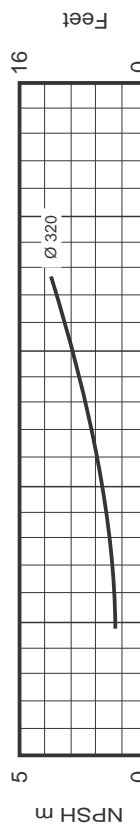
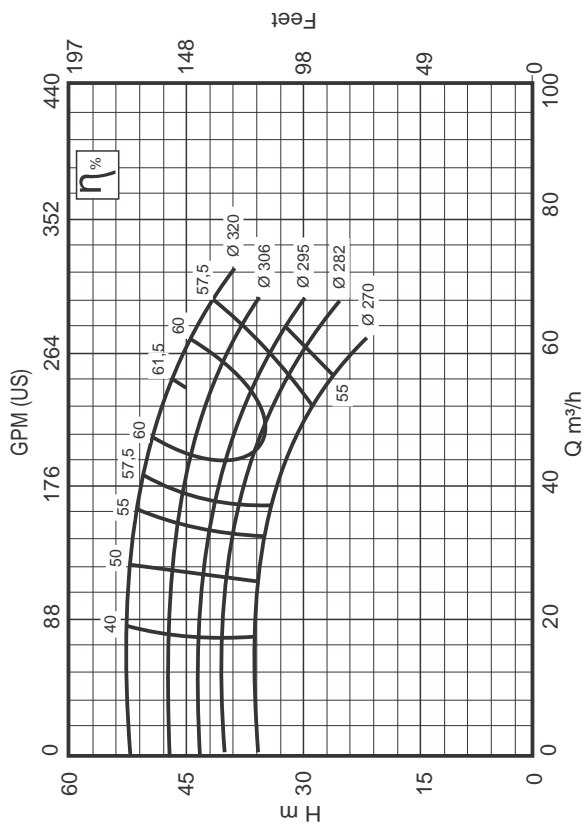

Impeller Ø Max. 320 mm
Impeller Ø Min. 270 mm
Impeller of Width 9 mm
Viscosity $\mu = 1\text{cP}$

Suction Flange 80 mm
Pressure Flange 50 mm
Specific Weight $\gamma = 1\text{kgf/dm}^3$

INI 65-200

1750 rpm

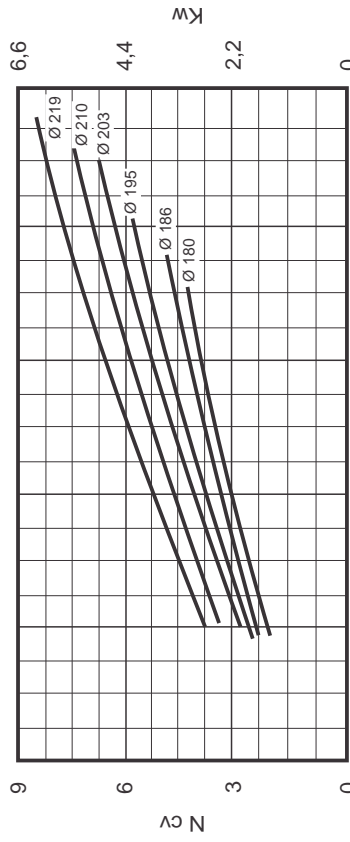
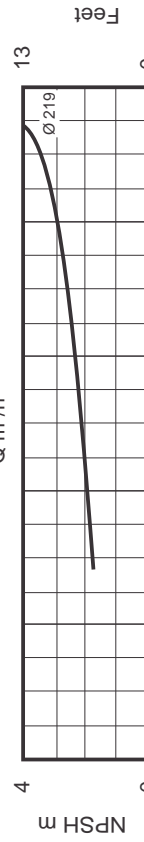
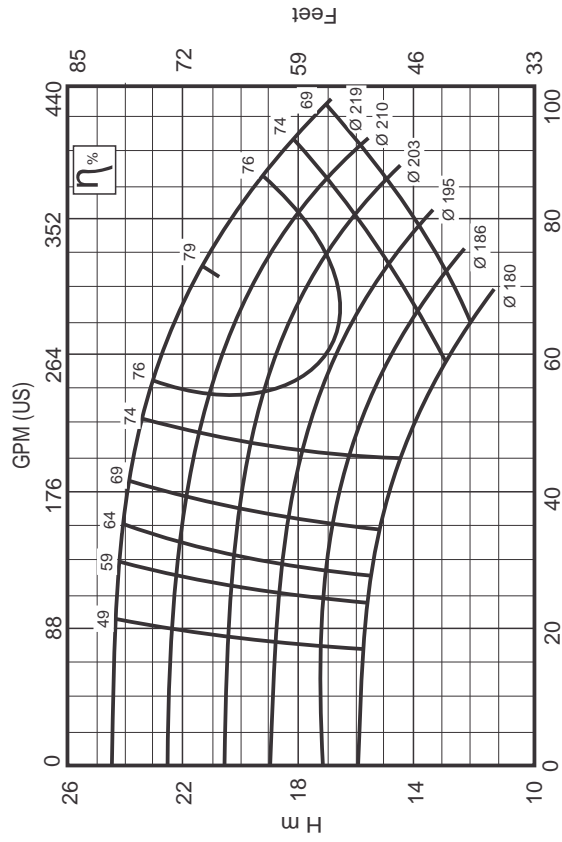

Suction Flange 100 mm
Pressure Flange 65 mm
Specific Weight $\gamma = 1 \text{ kgf/dm}^3$

Impeller Ø Max. 219 mm
Impeller Ø Min. 180 mm
Impeller of Width 17 mm
Viscosity $\mu = 1 \text{ cP}$

INI 65-160

1750 rpm

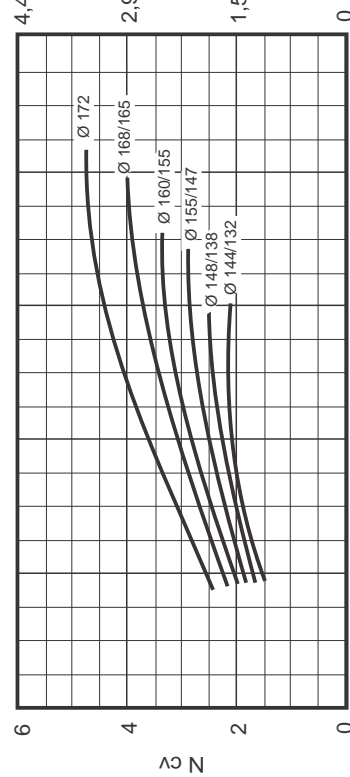
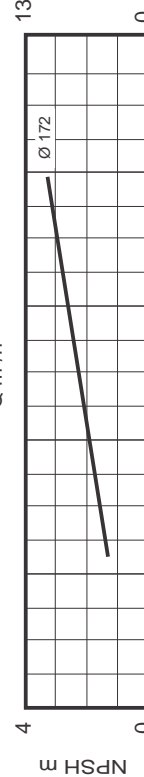
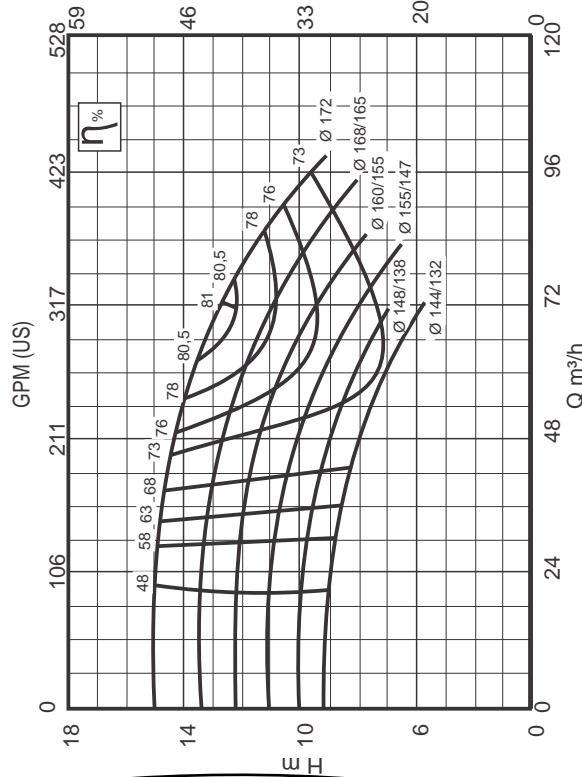

Suction Flange 100 mm
Pressure Flange 65 mm
Specific Weight $\gamma = 1 \text{ kgf/dm}^3$

Impeller Ø Max. 172 mm
Impeller Ø Min. 144/132 mm
Impeller of Width 21 mm
Viscosity $\mu = 1 \text{ cP}$

INI 65-315 1750 rpm

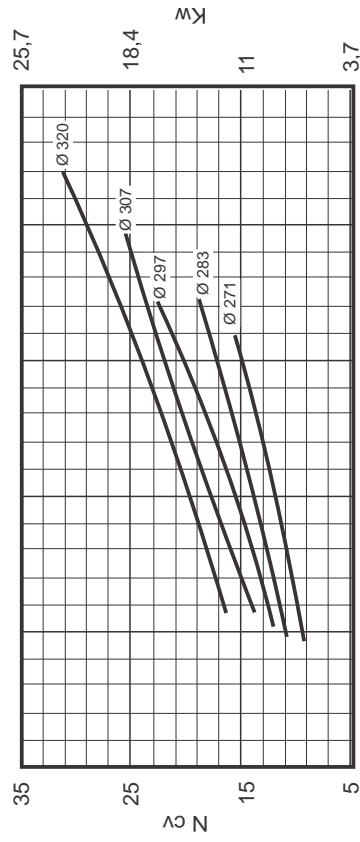
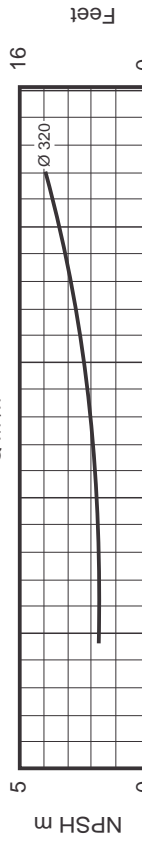
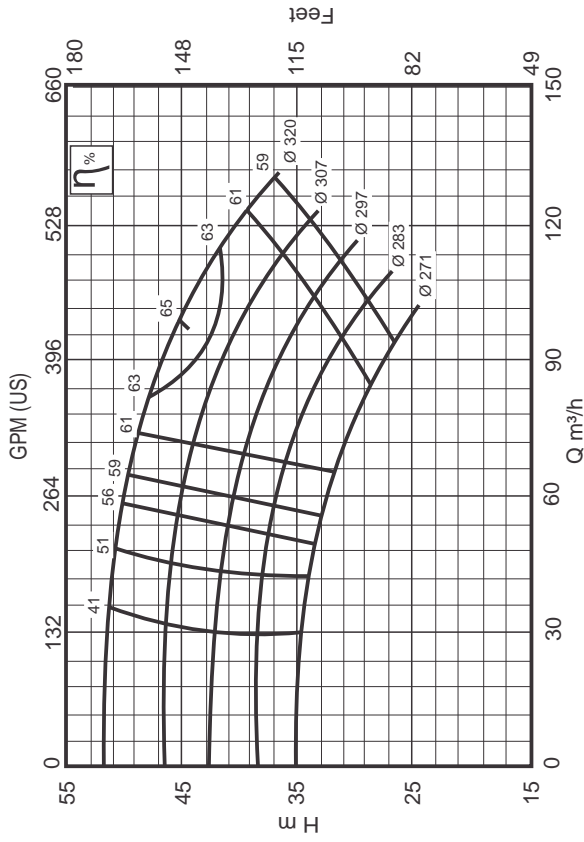

Suction Flange 100 mm
Pressure Flange 65 mm
Specific Weight $\gamma = 1 \text{ kgf/dm}^3$

Impeller Ø Max. 320 mm
Impeller Ø Min. 271 mm
Impeller of Width 13 mm
Viscosity $\mu = 1 \text{ cP}$

INI 65-250 1750 rpm

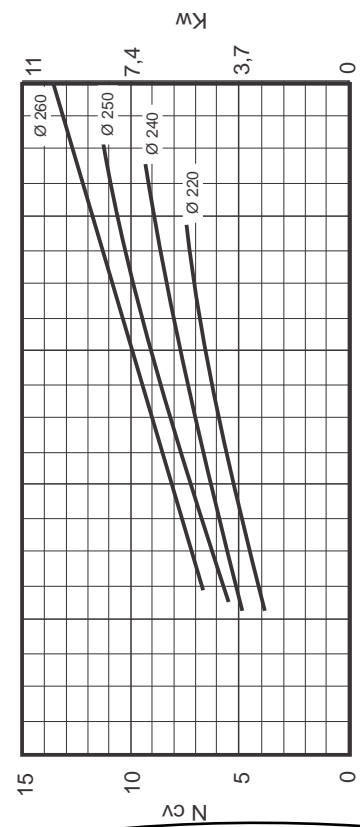
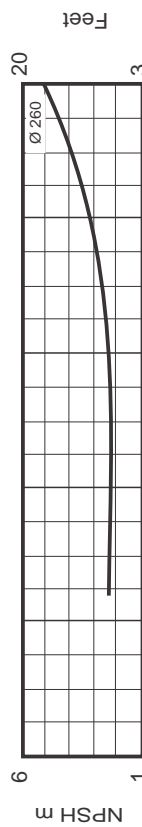
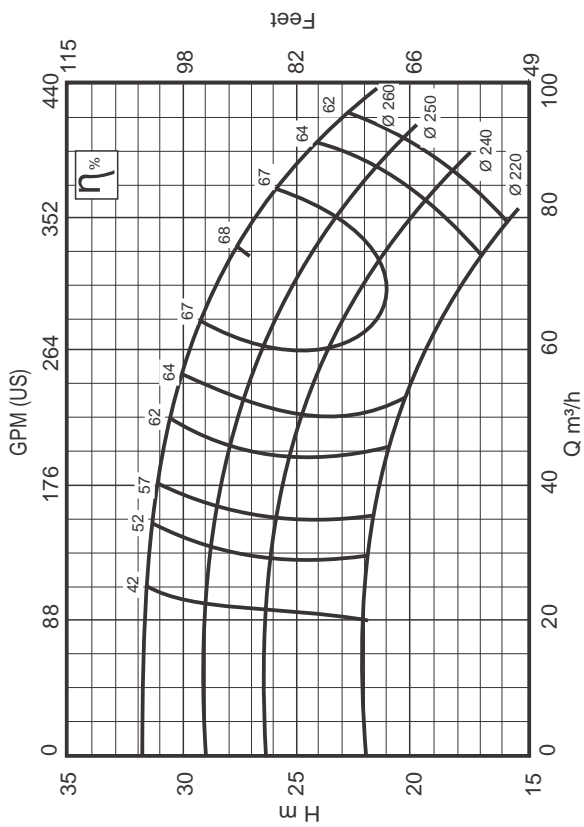

Suction Flange 100 mm
Pressure Flange 65 mm
Specific Weight $\gamma = 1 \text{ kgf/dm}^3$

Impeller Ø Max. 260 mm
Impeller Ø Min. 220 mm
Impeller of Width 13 mm
Viscosity $\mu = 1 \text{ cP}$

1750 rpm

INI 80-200

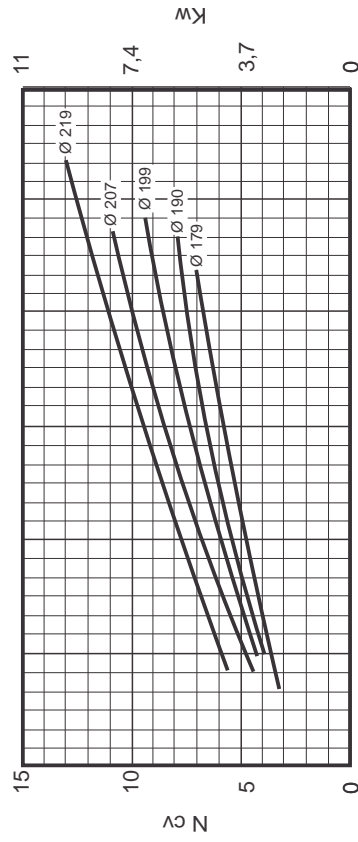
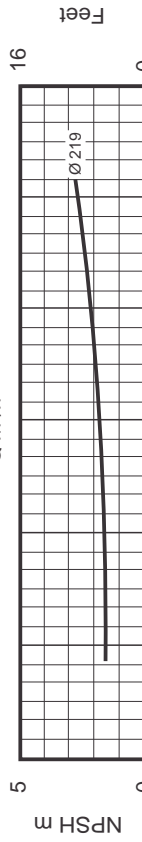
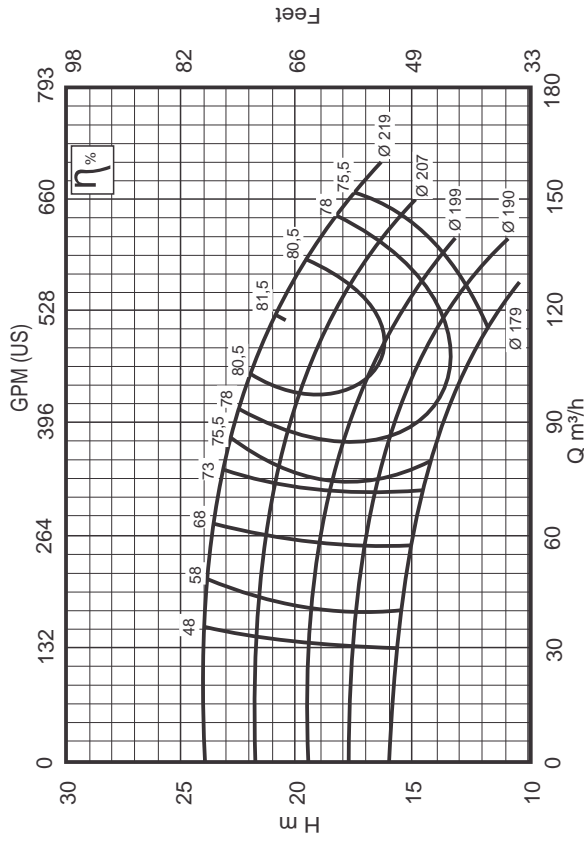

Suction Flange 125 mm
Pressure Flange 80 mm
Specific Weight $\gamma = 1 \text{ kgf/dm}^3$

Impeller Ø Max. 219 mm
Impeller Ø Min. 179 mm
Impeller of Width 23 mm
Viscosity $\mu = 1 \text{ cP}$

1750 rpm

INI 80-160

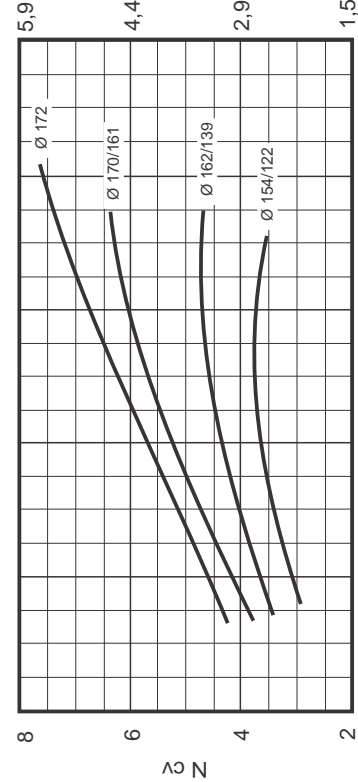
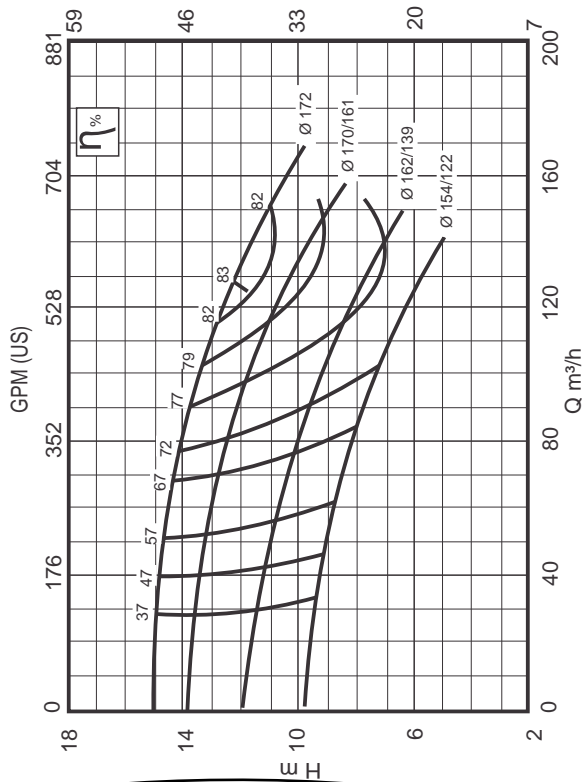

Suction Flange 125 mm
Pressure Flange 80 mm
Specific Weight $\gamma = 1 \text{ kgf/dm}^3$

Impeller Ø Max. 172 mm
Impeller Ø Min. 154/122 mm
Impeller of Width 31 mm
Viscosity $\mu = 1 \text{ cP}$

INI 80-315

1750 rpm

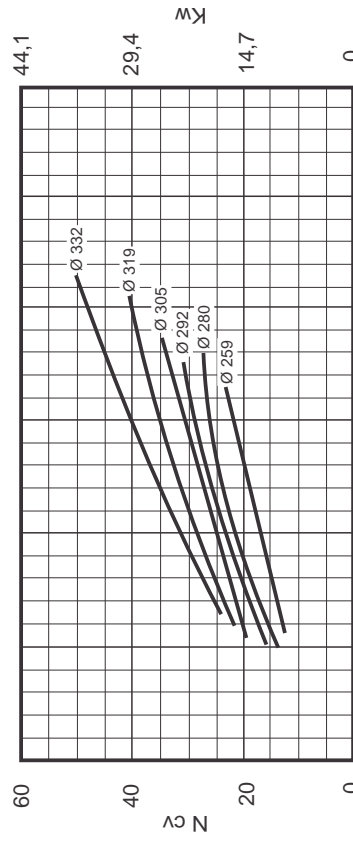
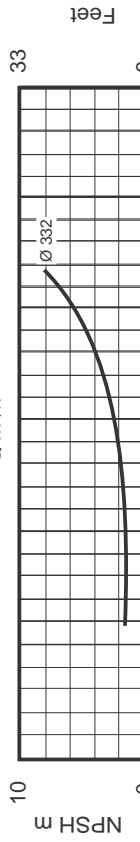
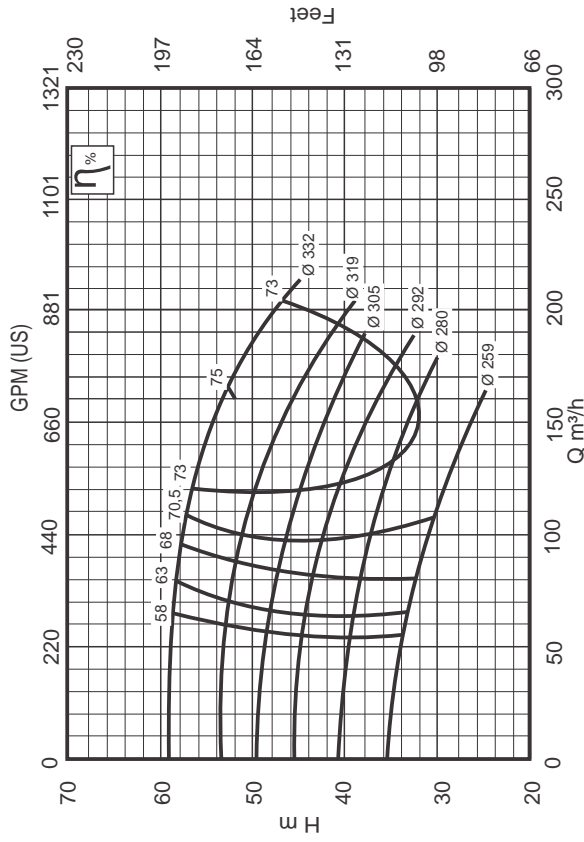

Impeller Ø Max. 332 mm
Impeller Ø Min. 259 mm
Impeller of Width 18 mm
Viscosity $\mu = 1\text{cP}$

Suction Flange 125 mm
Pressure Flange 80 mm
Specific Weight $\gamma = 1\text{kgf/dm}^3$

INI 80-250

1750 rpm

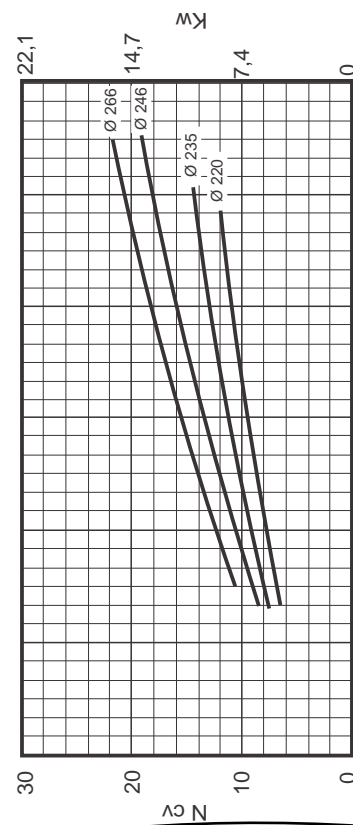
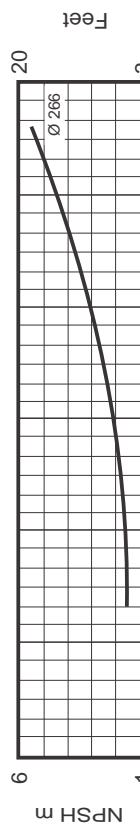
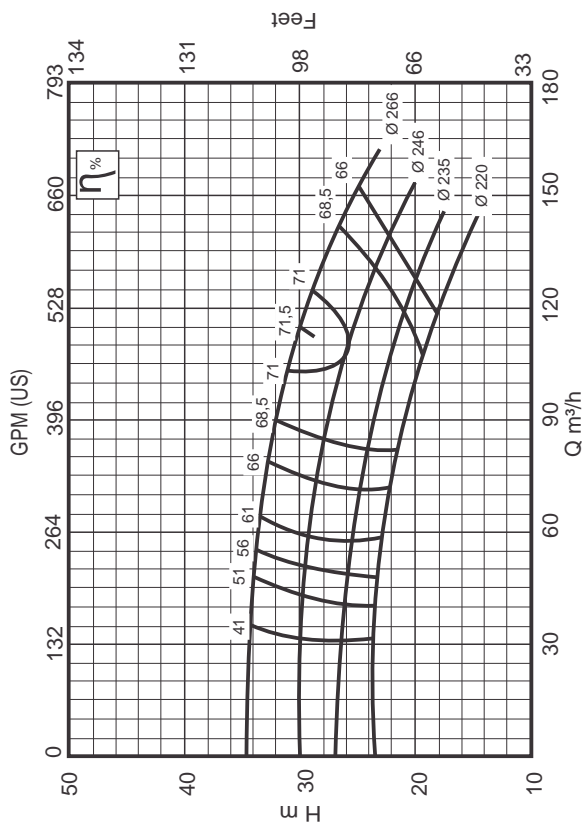

Impeller Ø Max. 266 mm
Impeller Ø Min. 220 mm
Impeller of Width 19 mm
Viscosity $\mu = 1\text{cP}$

Suction Flange 125 mm
Pressure Flange 80 mm
Specific Weight $\gamma = 1\text{kgf/dm}^3$

INI 100-160

1750 rpm

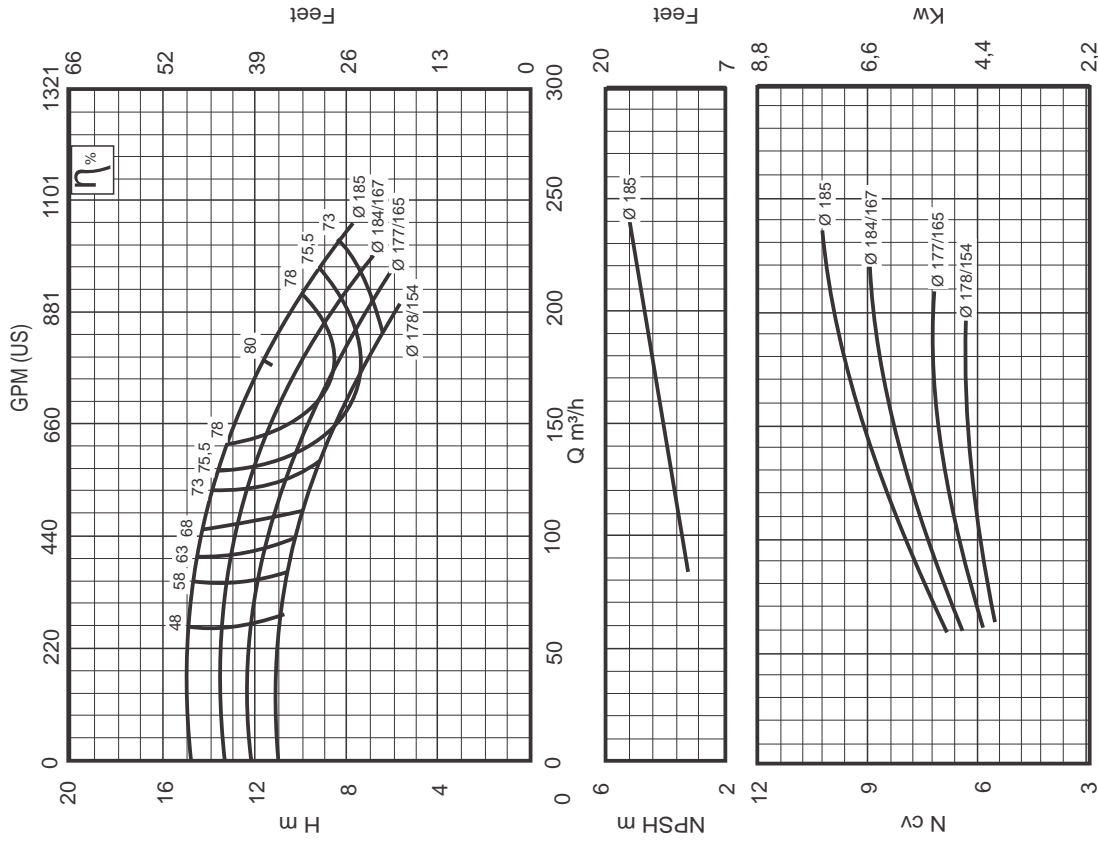

Impeller Ø Max. 185 mm
 Impeller Ø Min. 178/154 mm
 Impeller of Width 36 mm
 Viscosity $\mu = 1\text{cP}$

Suction Flange 125 mm
 Pressure Flange 80 mm
 Specific Weight $\gamma = 1\text{kgf/dm}^3$

INI 80-400

1750 rpm

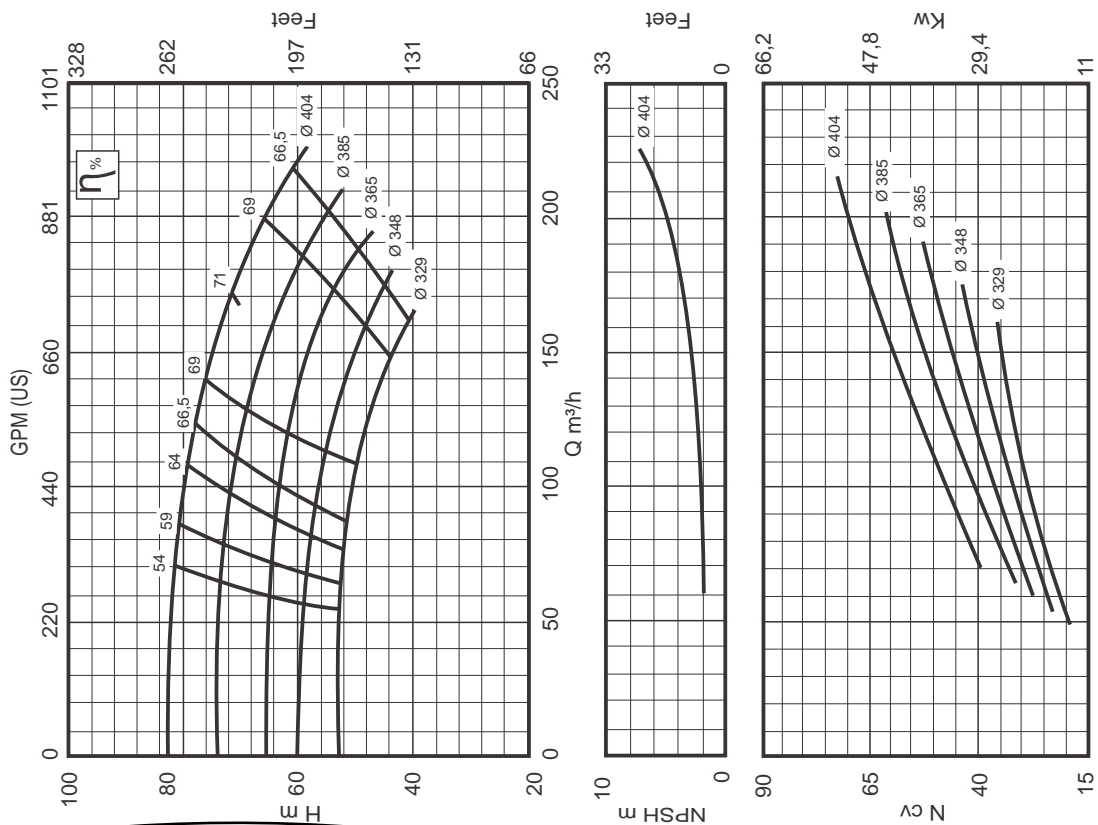

Impeller Ø Max. 404 mm
 Impeller Ø Min. 329 mm
 Impeller of Width 13 mm
 Viscosity $\mu = 1\text{cP}$

Suction Flange 125 mm
 Pressure Flange 80 mm
 Specific Weight $\gamma = 1\text{kgf/dm}^3$

1750 rpm

INI 100-250

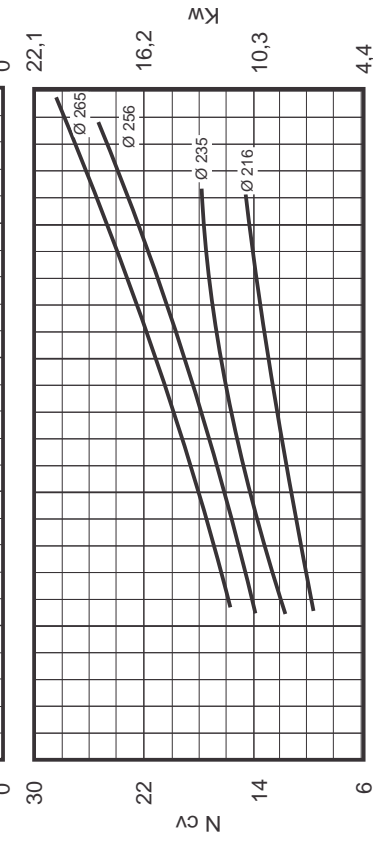
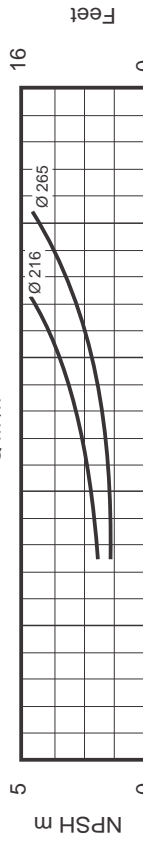
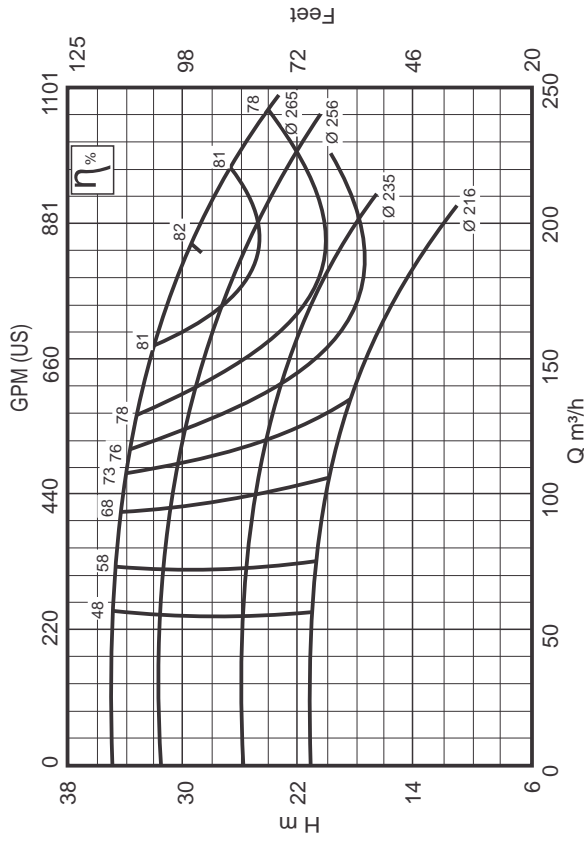

1750 rpm

INI 100-200

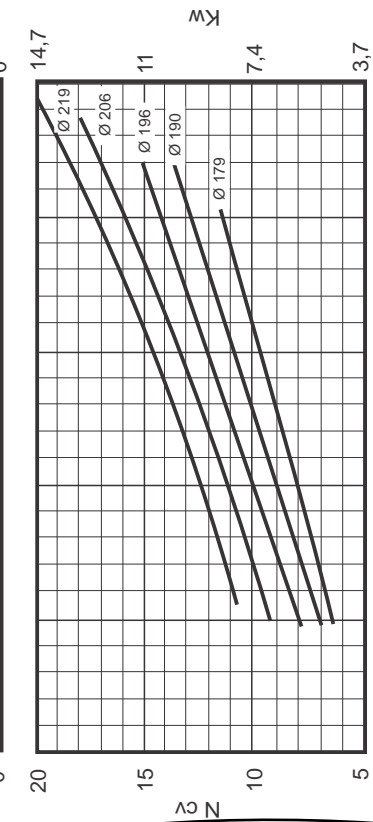
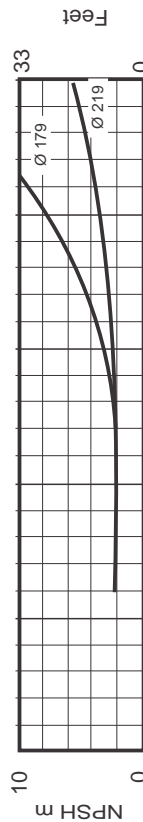
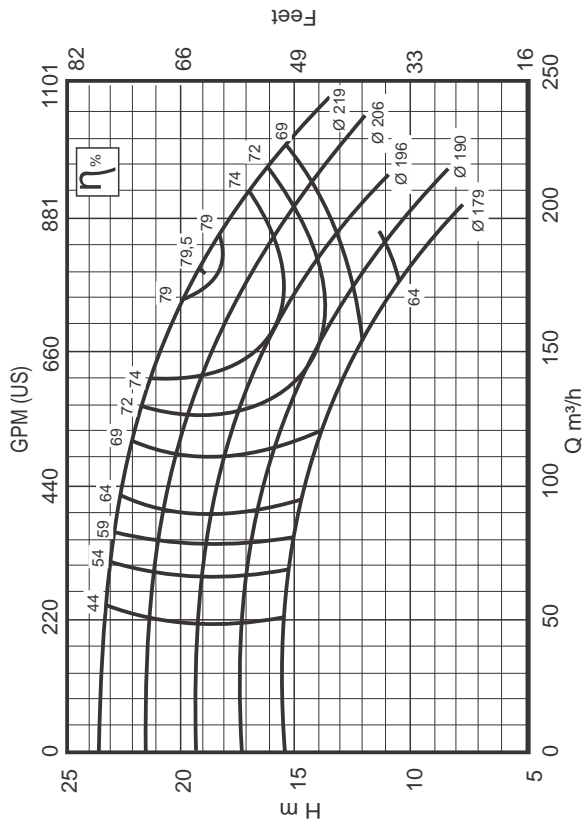

Impeller Ø Max. 265 mm
Impeller Ø Min. 216 mm
Impeller of Width 27 mm
Viscosity $\mu = 1\text{cP}$

Suction Flange 125 mm
Pressure Flange 100 mm
Specific Weight $\gamma = 1\text{kgf/dm}^3$

Impeller Ø Max. 219 mm
Impeller Ø Min. 179 mm
Impeller of Width 32 mm
Viscosity $\mu = 1\text{cP}$

Suction Flange 125 mm
Pressure Flange 100 mm
Specific Weight $\gamma = 1\text{kgf/dm}^3$

INI 100-400

1750 rpm

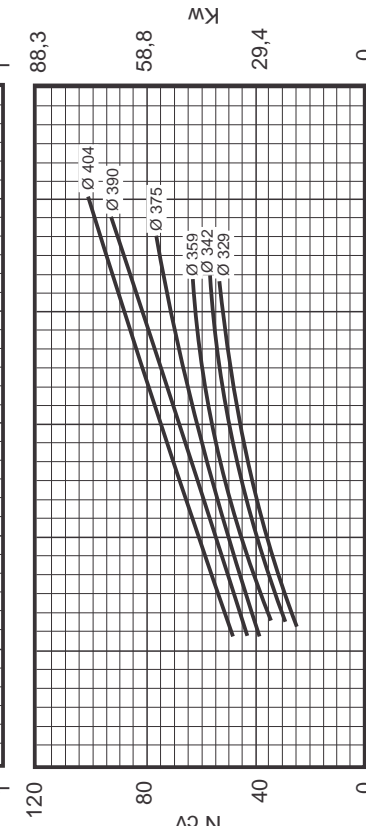
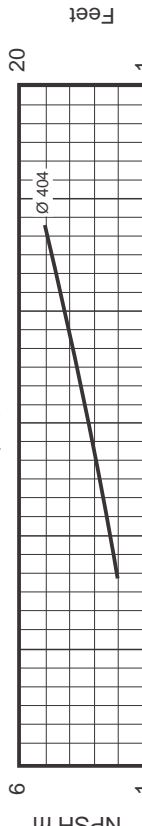
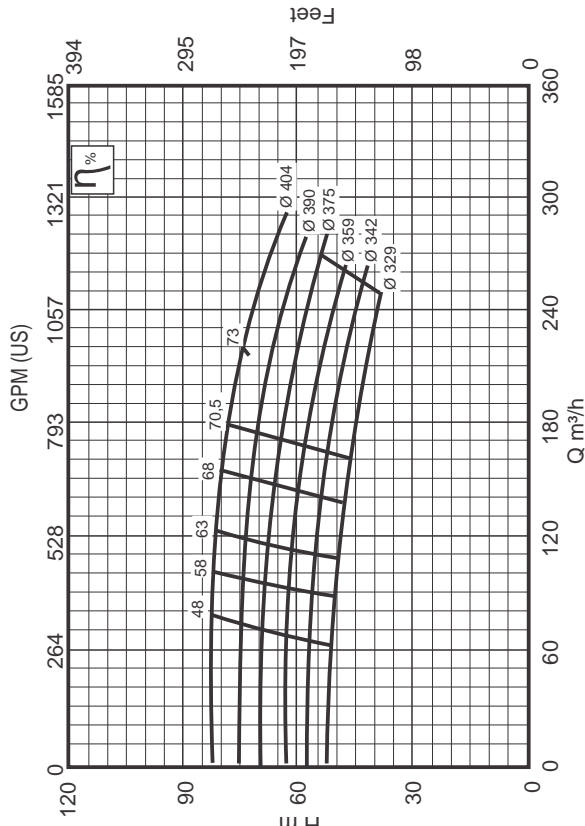

Impeller Ø Max. 404 mm
Impeller Ø Min. 329 mm
Impeller of Width 17 mm
Viscosity $\mu = 1\text{cP}$

Suction Flange 125 mm
Pressure Flange 100 mm
Specific Weight $\gamma = 1\text{kgf/dm}^3$

INI 100-315

1750 rpm

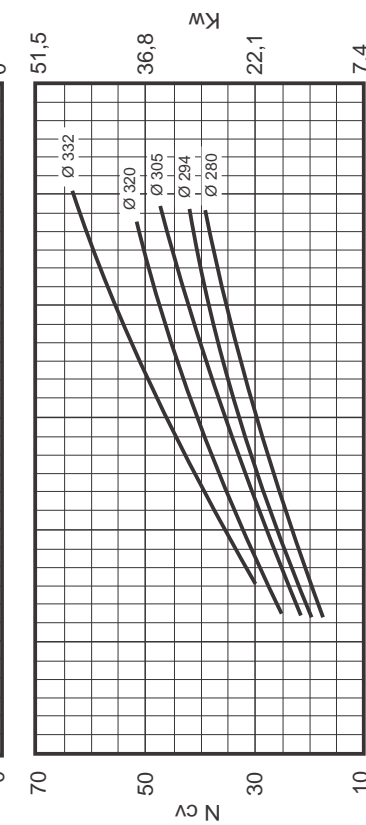
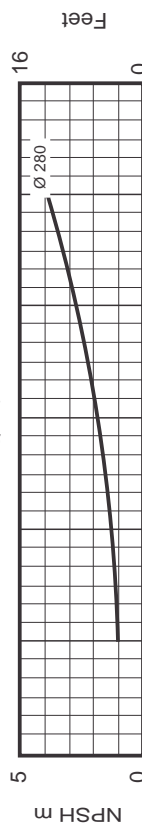
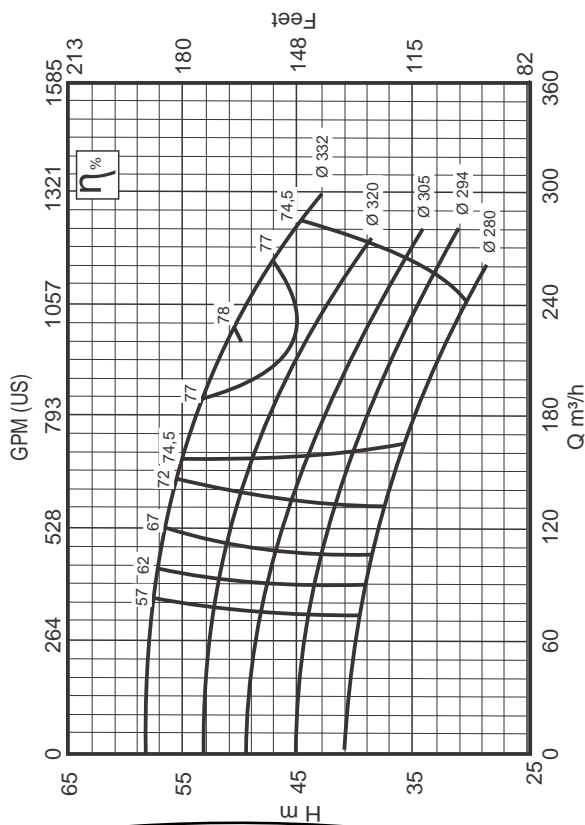

Impeller Ø Max. 332 mm
Impeller Ø Min. 280 mm
Impeller of Width 23 mm
Viscosity $\mu = 1\text{cP}$

Suction Flange 125 mm
Pressure Flange 100 mm
Specific Weight $\gamma = 1\text{kgf/dm}^3$

1750 rpm

INI 125-250

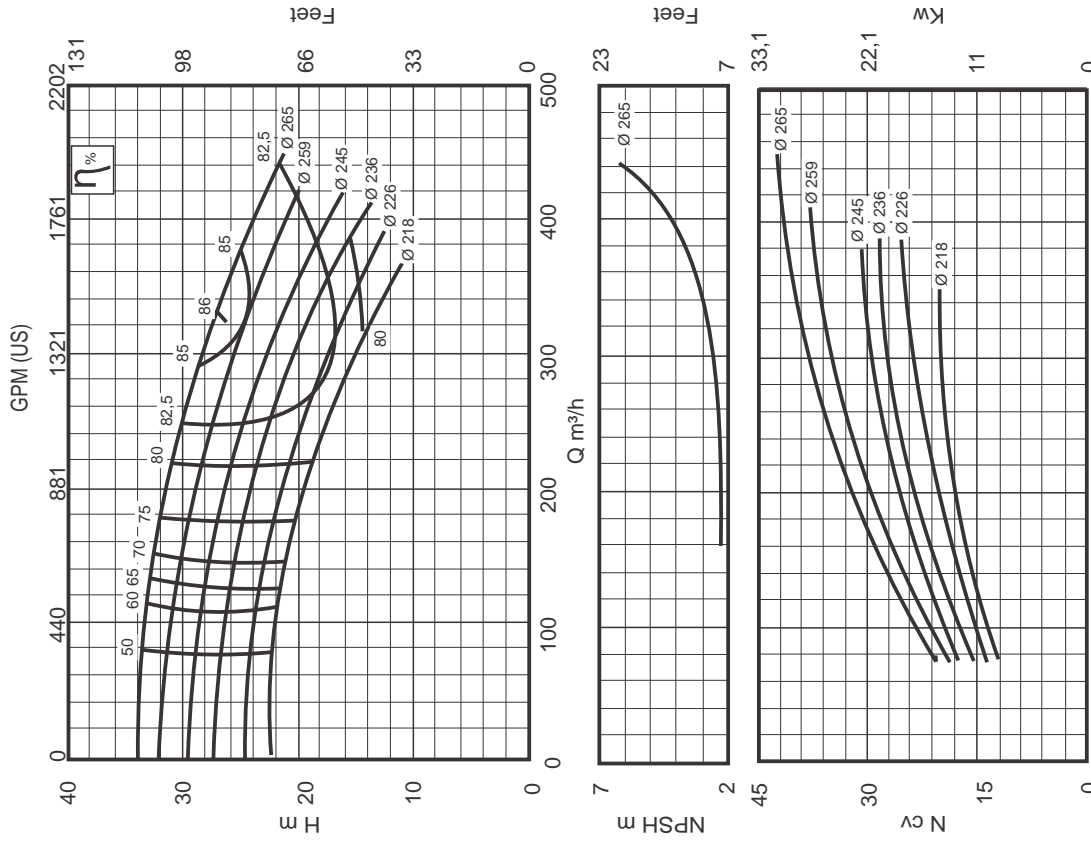

Suction Flange 150 mm
Pressure Flange 125 mm
Specific Weight $\gamma = 1 \text{ kgf/dm}^3$

Impeller Ø Max. 265 mm
Impeller Ø Min. 218 mm
Impeller of Width 37 mm
Viscosity $\mu = 1 \text{ cP}$

1750 rpm

INI 125-200

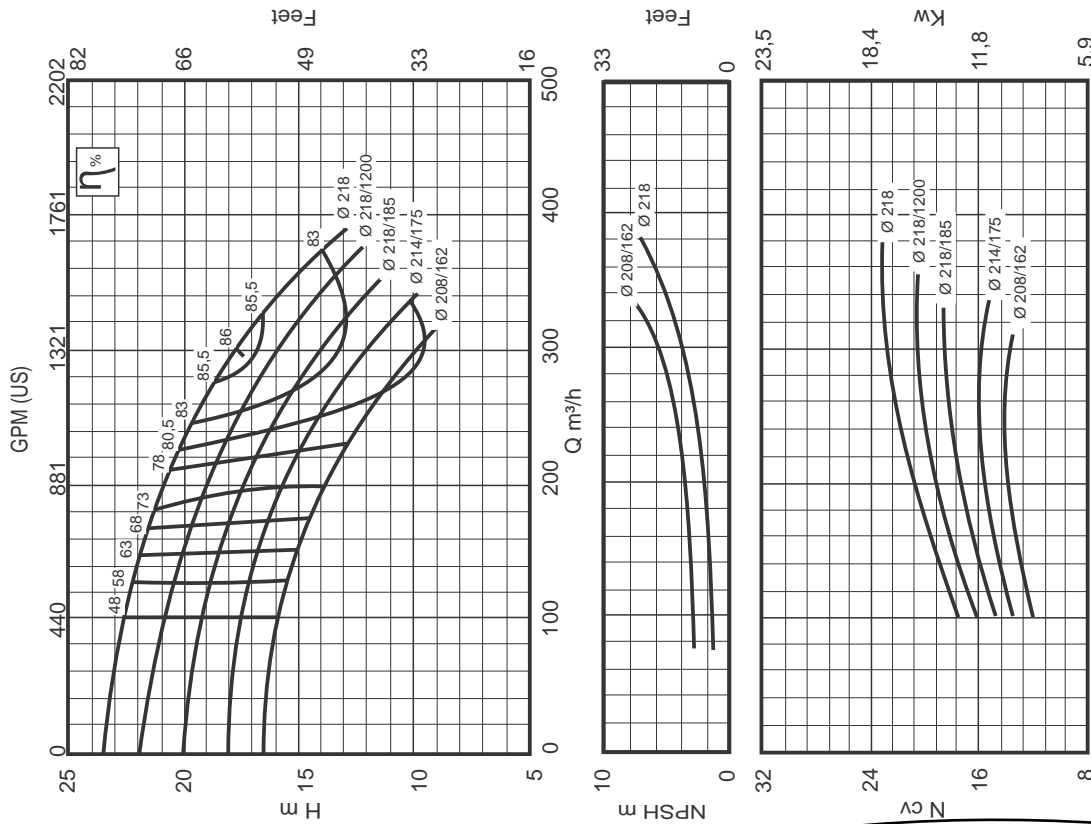

Suction Flange 150 mm
Pressure Flange 120 mm
Specific Weight $\gamma = 1 \text{ kgf/dm}^3$

Impeller Ø Max. 218 mm
Impeller Ø Min. 208/162 mm
Impeller of Width 40 mm
Viscosity $\mu = 1 \text{ cP}$

INI 125-400

1750 rpm

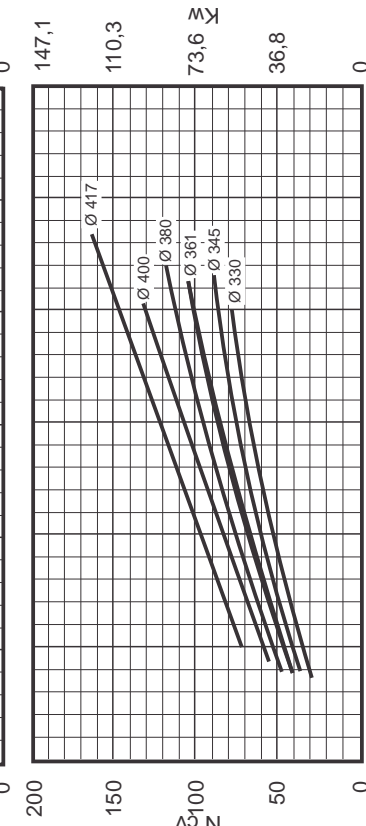
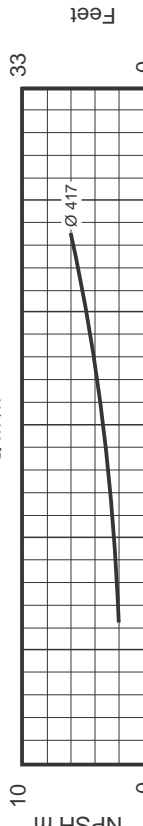
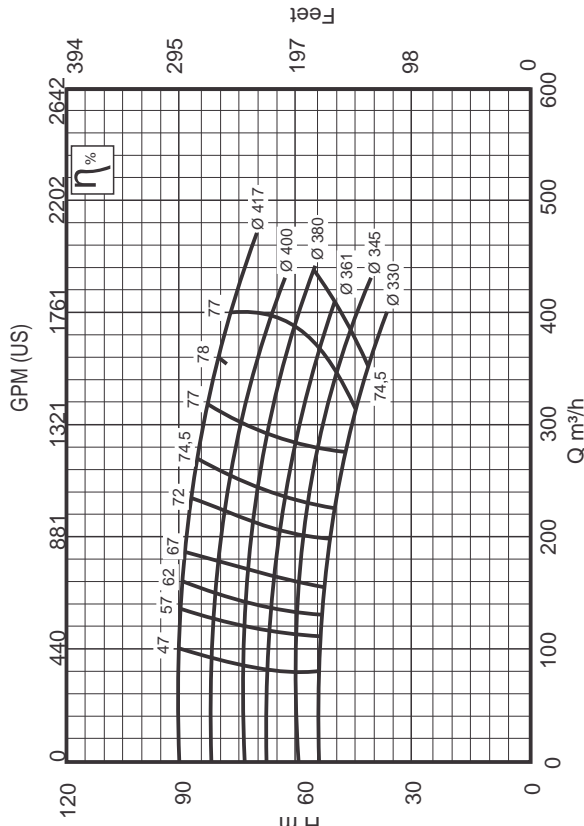

Impeller Ø Max. 417 mm
Impeller Ø Min. 330 mm
Impeller of Width 25 mm
Viscosity $\mu = 1\text{cP}$

Suction Flange 150 mm
Pressure Flange 125 mm
Specific Weight $\gamma = 1\text{kgf/dm}^3$

INI 125-315

1750 rpm

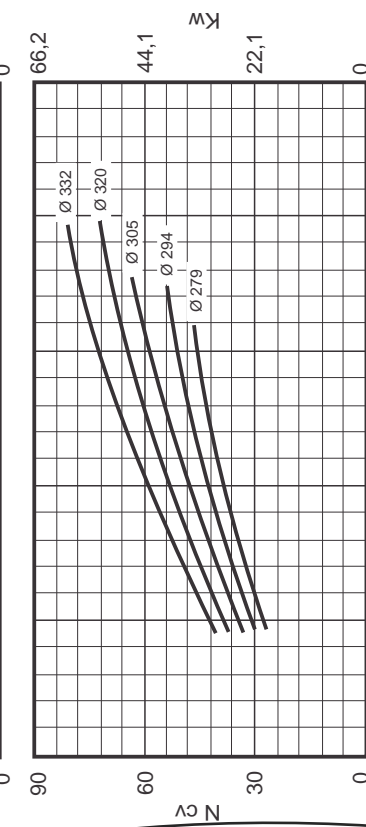
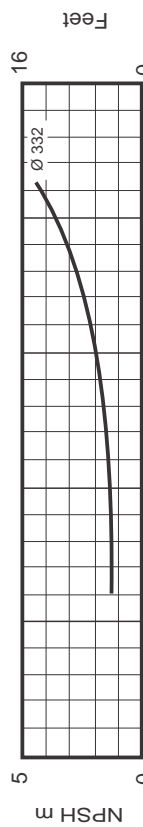
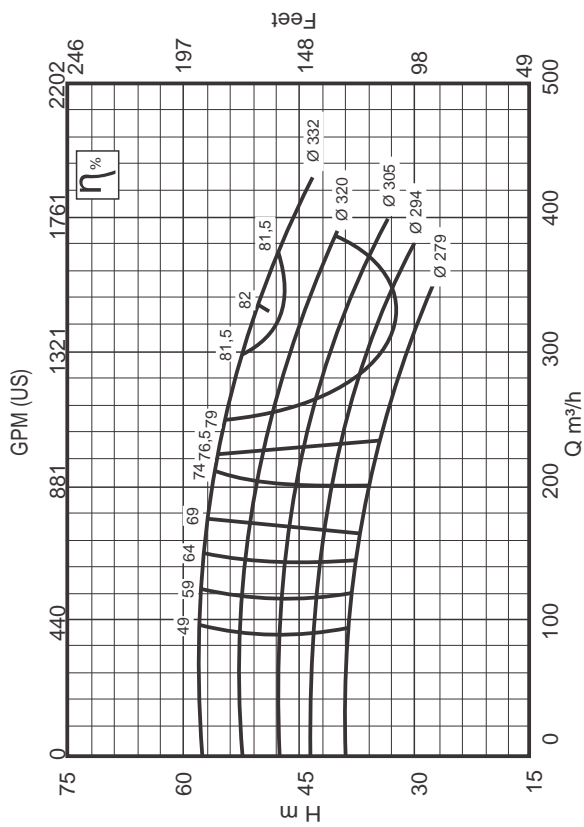

Impeller Ø Max. 218 mm
Impeller Ø Min. 218/153 mm
Impeller of Width 59 mm
Viscosity $\mu = 1\text{cP}$

Suction Flange 150 mm
Pressure Flange 125 mm
Specific Weight $\gamma = 1\text{kgf/dm}^3$

INI 150-250 1750 rpm

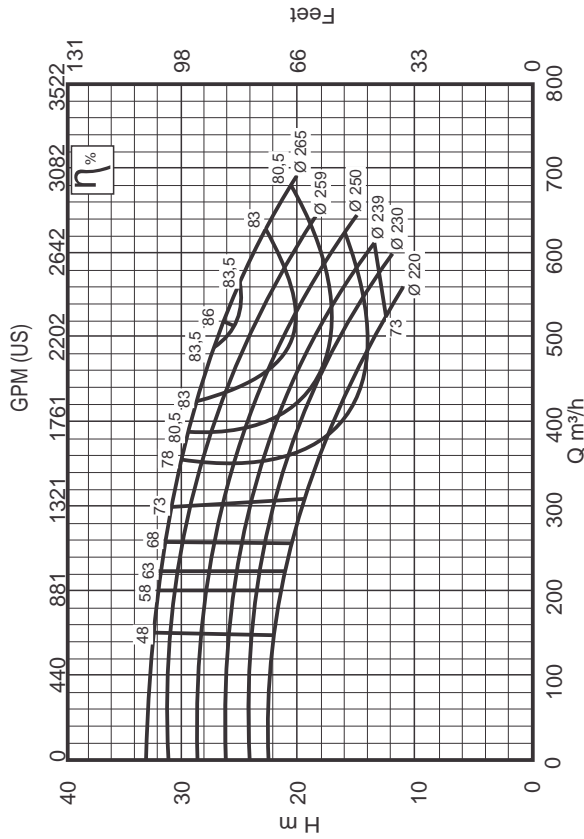

INI 150-200 1750 rpm

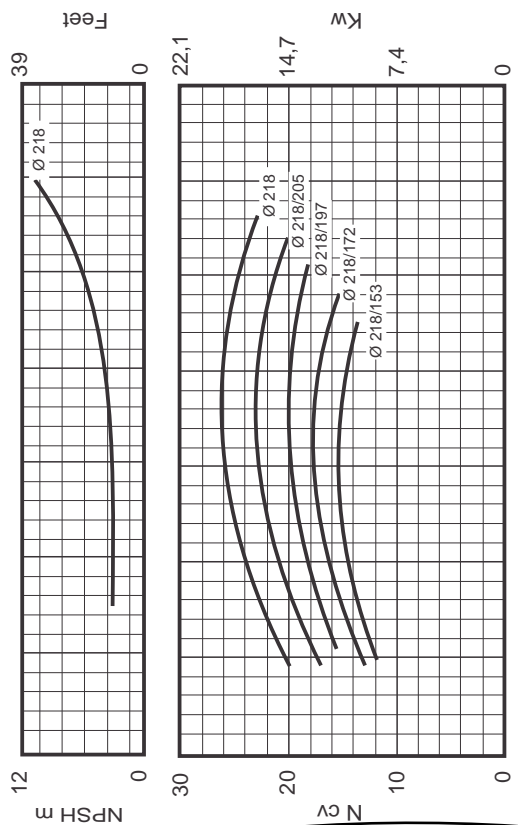
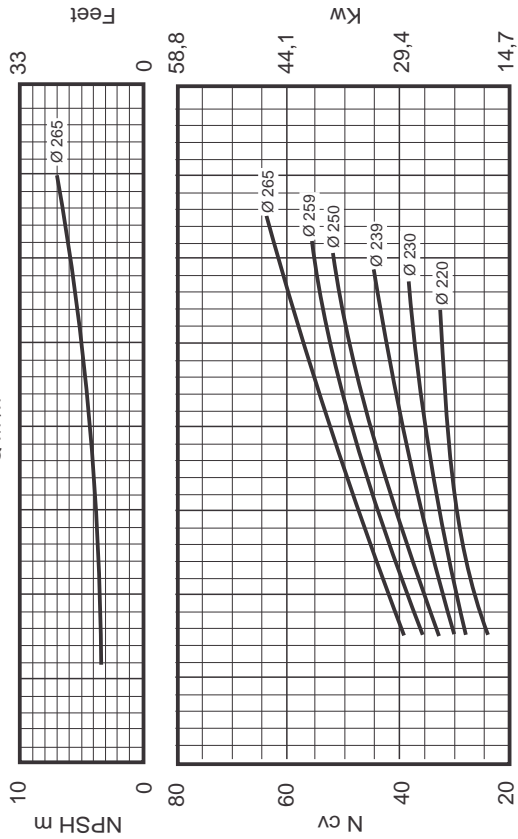
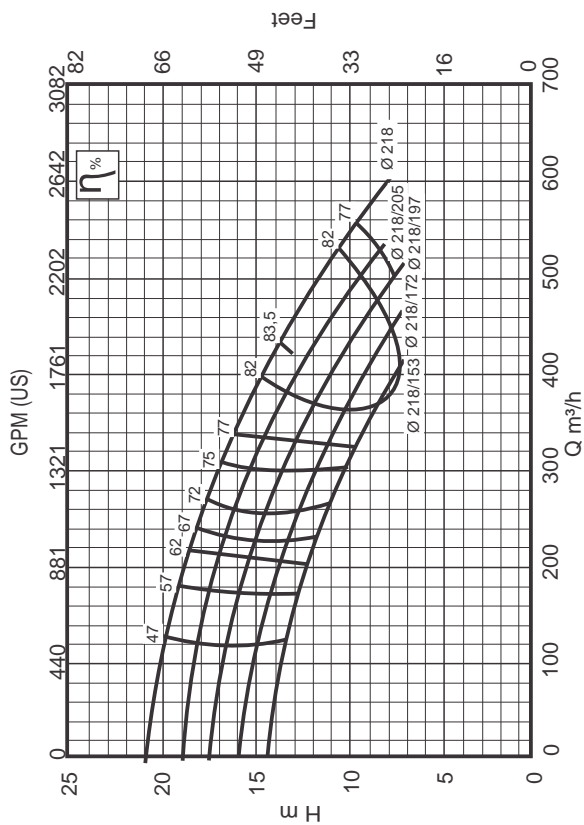

Suction Flange 200 mm
Pressure Flange 150 mm
Specific Weight $\gamma = 1 \text{ kgf/dm}^3$

Impeller Ø Max. 265 mm
Impeller Ø Min. 220 mm
Impeller of Width 12 mm
Viscosity $\mu = 1 \text{ cP}$

Suction Flange 200 mm
Pressure Flange 150 mm
Specific Weight $\gamma = 1 \text{ kgf/dm}^3$

Impeller Ø Max. 218 mm
Impeller Ø Min. 153 mm
Impeller of Width 59 mm
Viscosity $\mu = 1 \text{ cP}$

1750 rpm

INI 150-400

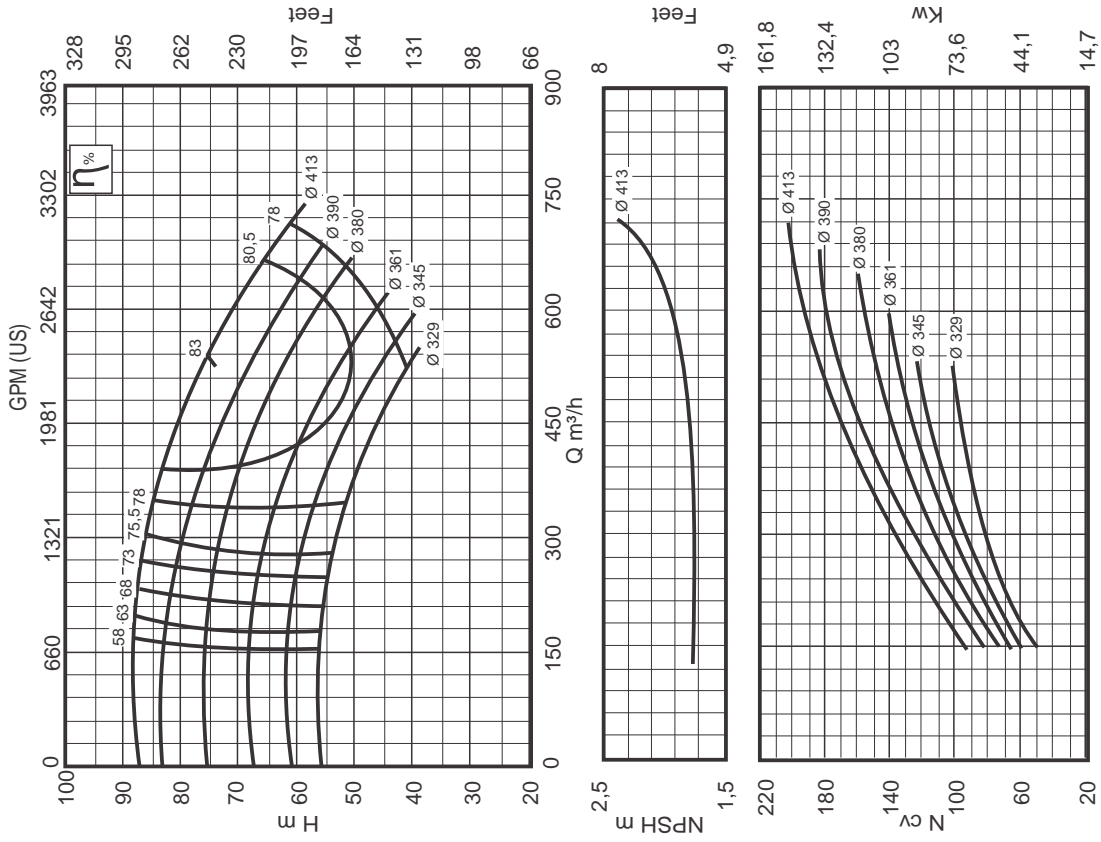

Impeller Ø Max. 413 mm
 Impeller Ø Min. 329 mm
 Impeller of Width 33 mm
 Viscosity $\mu = 1\text{cP}$

Suction Flange 200 mm
 Pressure Flange 150 mm
 Specific Weight $\gamma = 1\text{kgf/dm}^3$

1750 rpm

INI 150-315

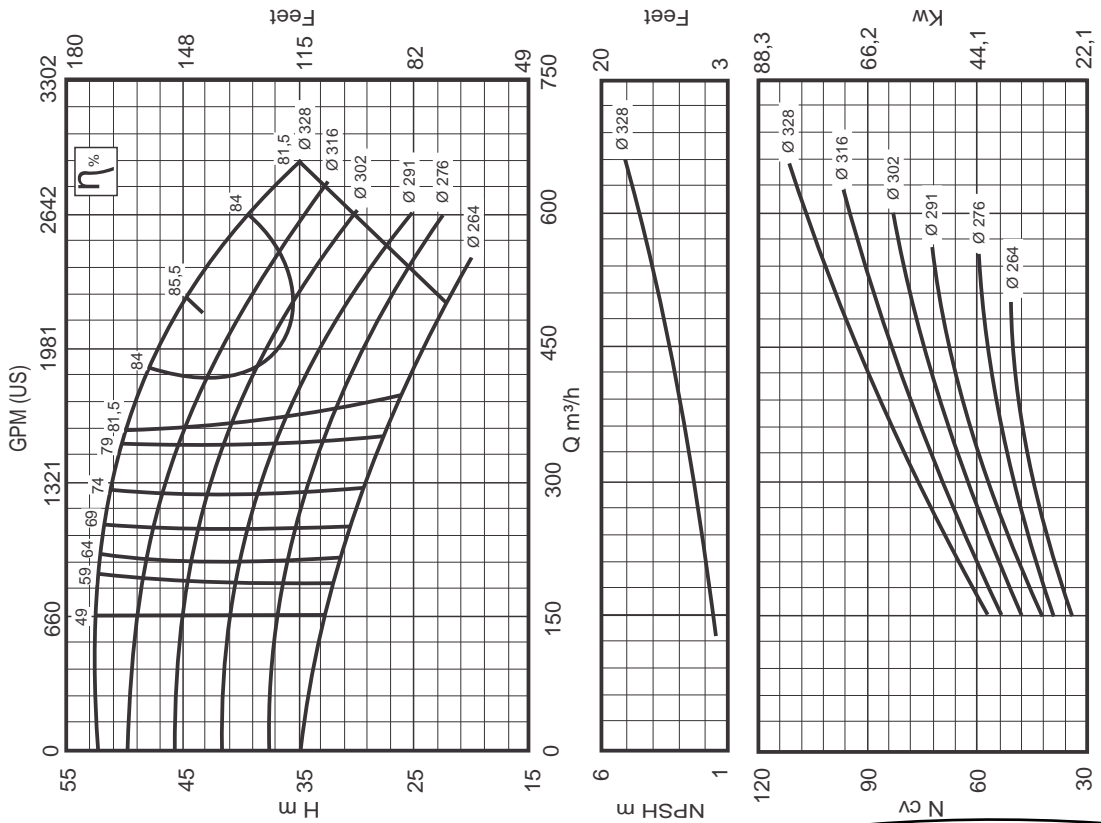

Impeller Ø Max. 328 mm
 Impeller Ø Min. 264 mm
 Impeller of Width 39 mm
 Viscosity $\mu = 1\text{cP}$

Suction Flange 200 mm
 Pressure Flange 150 mm
 Specific Weight $\gamma = 1\text{kgf/dm}^3$

