

# PWV

**API 610  
Vertical Turbine Pump  
VS6 (Can Type)  
VS1 (Sump Type)**



# PWV API 610 VERTICAL TURBINE PUMP

## HYDRAULIC PERFORMANCE COVERAGE

**60 Hz  
Performance Coverage  
3560 RPM & 1780 RPM**

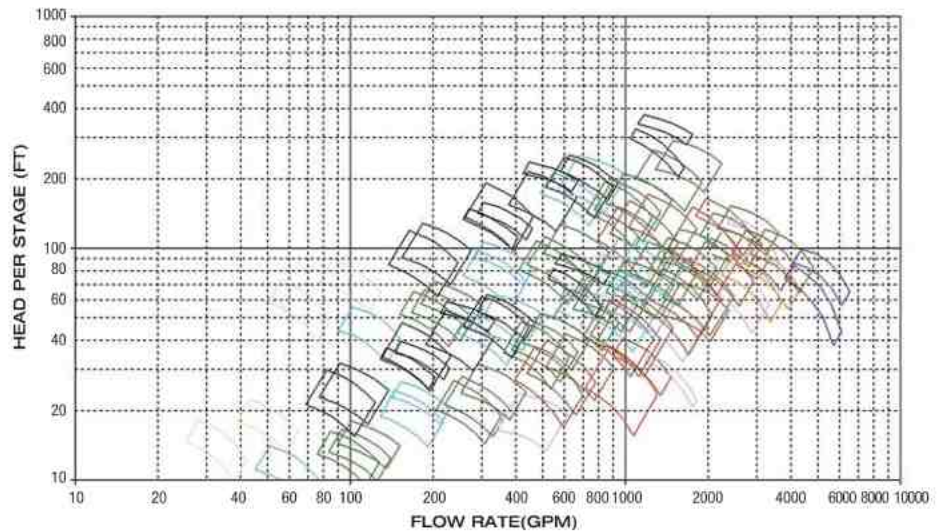

**50 Hz  
Performance Coverage  
2950 RPM & 1475 RPM**

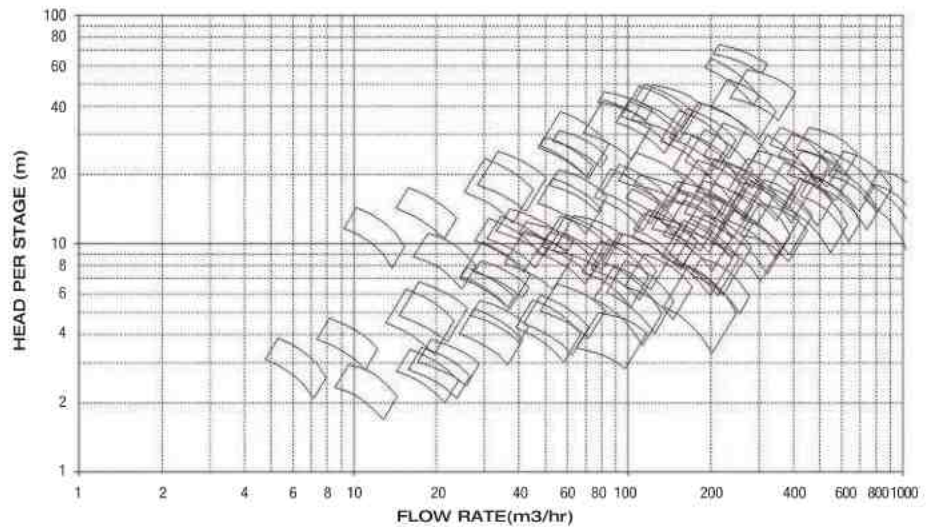

Performances shown are normal and are to be used for preliminary selection only.

## STANDARD MATERIALS OF CONSTRUCTION VS6 (Can Type)

API MATERIAL CLASS	S-4	S-5	S-6	S-8	A-8	D-1	D-2
DISCHARGE HEAD	A106 GRADE B CARBON STEEL PIPE	A106 GRADE B CARBON STEEL PIPE	A106 GRADE B CARBON STEEL PIPE	A106 GRADE B CARBON STEEL PIPE	A312 GRADE TP316LSS PIPE	A790-S31803	A790-S32760
SUCTION BARREL / CAN	A106 GRADE B CARBON STEEL PIPE	A106 GRADE B CARBON STEEL PIPE	A106 GRADE B CARBON STEEL PIPE	A106 GRADE B CARBON STEEL PIPE	A312 GRADE TP316LSS PIPE	A790-S31803	A790-S32760
COLUMN PIPE	A106 GRADE B CARBON STEEL PIPE	A106 GRADE B CARBON STEEL PIPE	A106 GRADE B CARBON STEEL PIPE	A106 GRADE B CARBON STEEL PIPE	A312 GRADE TP316LSS PIPE	A790-S31803	A790-S32760
BOWL	A536 GR 80-40-18 DUCTILE IRON	A216 GRADE WCB	A487 GRADE C6NM	A351-CF3M	A351-CF3M	A890 GRADE 4A	A890 GRADE 4A
IMPELLER	A216 GRADE WCB	A216 GRADE WCB	A743 GRADE C6NM	A743 GR-CF3M	A743 GR-CF3M	A890 GRADE 4A	A890 GRADE 4A
BOWL WEAR RING	A48 CLASS 30 CAST IRON	420 SS HT: 262-302 BHN	420SS HT 400-450 BHN	316 SS HARD FACED	316 SS HARD FACED	A276-S31803	A276-S32760
IMPELLER WEAR RING	A48 CLASS 30 CAST IRON	410 SS HT: 400-450 BHN	410SS HT 262-302 BHN	316 SS HARD FACED	316 SS HARD FACED	A276-S31803	A276-S32760
COLUMN SHAFT	A582 TYPE 416 SS HT	A582 TYPE 416 SS HT	A582 TYPE 416SS HT	A479 TYPE 316 / 316L	A479 TYPE 316 / 316L	B865 MONEL K-500	B865 MONEL K-500
BOWL ASSEMBLY SHAFT	A582 TYPE 416 SS HT	A582 TYPE 416 SS HT	A582 TYPE 416SS HT	A479 TYPE 316 / 316L	A479 TYPE 316 / 316L	B865 MONEL K-500	B865 MONEL K-500
COLUMN SHAFT BUSHING	GRAPHALLOY CARBON	GRAPHALLOY CARBON	GRAPHALLOY CARBON	GRAPHALLOY CARBON	GRAPHALLOY CARBON	GRAPHALLOY CARBON	GRAPHALLOY CARBON
BOWL SHAFT BUSHING	GRAPHALLOY CARBON	GRAPHALLOY CARBON	GRAPHALLOY CARBON	GRAPHALLOY CARBON	GRAPHALLOY CARBON	GRAPHALLOY CARBON	GRAPHALLOY CARBON
COLUMN STUDS	A193 GRADE B7	A193 B8M	A193 B8M	A193 B8M	A193 B8M	A276-S31803	A276-S32760
COLUMN NUTS	A194 GRADE 2H	A194 BM	A194 BM	A194 BM	A194 BM	A276-S31803	A276-S32760
BOWL STUDS	A193 GRADE B7	A193 B8M	A193 B8M	A193 B8M	A193 B8M	A276-S31803	A276-S32760
GASKET	O-RING	O-RING	O-RING	O-RING	O-RING	O-RING	O-RING

\*Other API 610 Material Classes and Combinations are available

# PWV API 610 VERTICAL TURBINE PUMP

## DESIGN FEATURES AND BENEFITS

### Quality

- Manufactured and tested in the USA

#### Barrel and Discharge Head

- Mounting flange O-Ring for positive sealing

#### Barrel Mounting Plate

- Supplied with 4 jackscrews for leveling
- Optional Soleplate

#### Suction Barrel

- BPW Standard blasted to SSPC-6 and externally coated Sherwin Williams Macropoxy 646 FC for excellent anti-corrosive protection in industrial, coastal structures, and offshore environments in both atmospheric exposure and immersion service
- Fabricated steel designed and welded in accordance with ASME Section VIII
- Welded in accordance to ASME code section IX certified weld procedure qualification
- Designed to minimize velocity along the can length resulting in optimum hydraulic inlet conditions at the suction bowl entrance
- Optional below ground suction connection
- Optional drain piping (internal or external)

#### Bearing Retainer

- Welded into the column section to assure alignment and concentricity

- **Renewable Bowl and Impeller Wear Rings**
  - Permits re-establishing initial running clearances and efficiency

#### Bowl Bearing

- Provides hydraulic shaft support to each stage
- Optional materials to meet wide range of process fluids

#### Bowl

- Diffuser type casing has low radial thrust and provides down thrust to keep shaft in tension during normal operation effectively reducing shaft deflection and vibration
- Flanged and o-ring sealed connection to provide ease of maintenance
- Radial hydraulic forces are equalized by multi-vane passages reducing shaft loading and exceptional bearing life

#### Impeller

- Fully enclosed design for high efficiency and eliminates critical field adjustments required by semi or open impeller
- Dynamically balanced per ISO G1.0 for vibration free operation
- Keyed to shaft for longer life, and less maintenance
- Optional thrust balancing to reduce axial thrust load

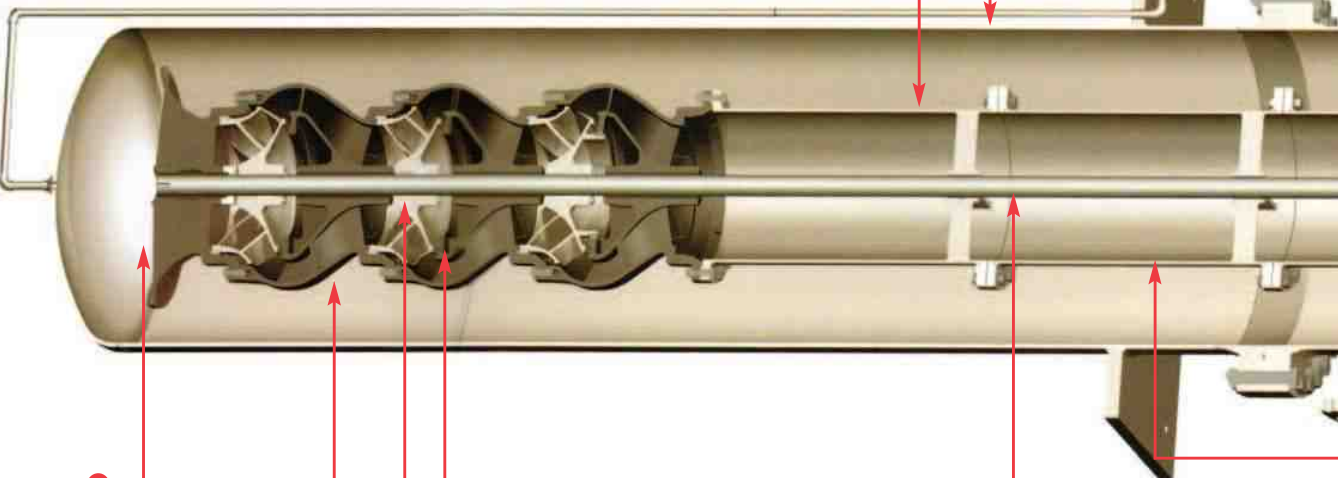

## API-610 CONSTRUCTION Vertical Turbine Pump (Double Casing)

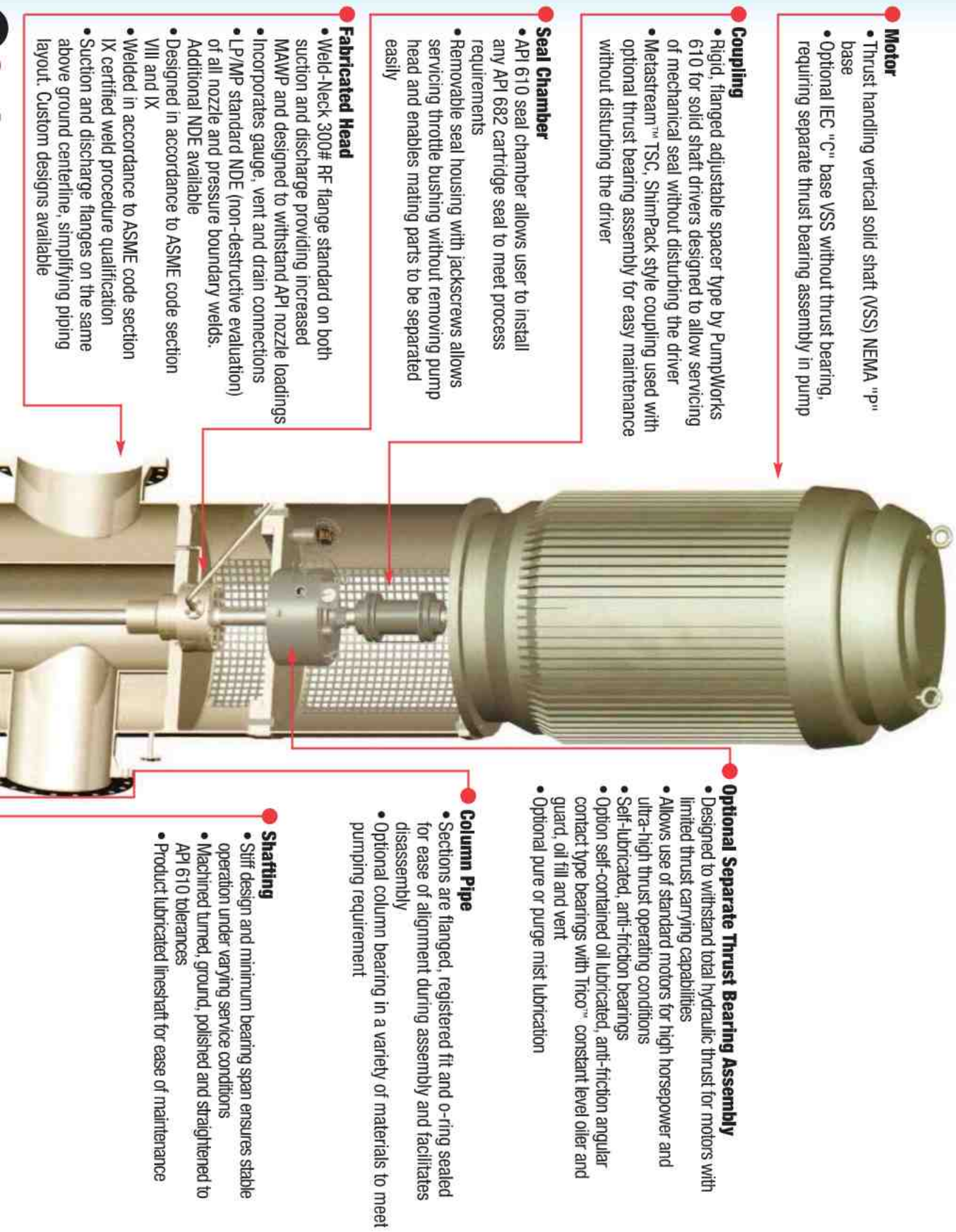

- **Motor**
  - Thrust handling vertical solid shaft (VSS) NEMA "P" base
  - Optional IEC "C" base VSS without thrust bearing, requiring separate thrust bearing assembly in pump

- **Coupling**
  - Rigid, flanged adjustable spacer type by PumpWorks 610 for solid shaft drivers designed to allow servicing of mechanical seal without disturbing the driver
  - Metastream™ TSC, ShimPack style coupling used with optional thrust bearing assembly for easy maintenance without disturbing the driver

- **Seal Chamber**
  - API 610 seal chamber allows user to install any API 682 cartridge seal to meet process requirements
  - Removable seal housing with jackscrews allows servicing throttle bushing without removing pump head and enables mating parts to be separated easily

- **Fabricated Head**
  - Weld-Neck 300# RF flange standard on both suction and discharge providing increased MAWP and designed to withstand API nozzle loadings
  - Incorporates gauge, vent and drain connections
  - LP/MP standard NDE (non-destructive evaluation) of all nozzle and pressure boundary welds. Additional NDE available
  - Designed in accordance to ASME code section VIII and IX
  - Welded in accordance to ASME code section IX certified weld procedure qualification
  - Suction and discharge flanges on the same above ground centerline, simplifying piping layout. Custom designs available

- **Optional Separate Thrust Bearing Assembly**
  - Designed to withstand total hydraulic thrust for motors with limited thrust carrying capabilities
  - Allows use of standard motors for high horsepower and ultra-high thrust operating conditions
  - Self-lubricated, anti-friction bearings
  - Option self-contained oil lubricated, anti-friction angular contact type bearings with Trico™ constant level oiler and guard, oil fill and vent
  - Optional pure or purge mist lubrication

- **Column Pipe**
  - Sections are flanged, registered fit and o-ring sealed for ease of alignment during assembly and facilitates disassembly
  - Optional column bearing in a variety of materials to meet pumping requirement

- **Shafting**
  - Stiff design and minimum bearing span ensures stable operation under varying service conditions
  - Machined turned, ground, polished and straightened to API 610 tolerances
  - Product lubricated lineshaft for ease of maintenance

# PWV API 610 VERTICAL TURBINE PUMP

## OUTLINE DIMENSIONS VS6 (Can Type)

### BARREL AND BOWL DIMENSIONS (Inches)

BOWL SIZE	BL	BM & B	BN	BP	E	APPROX. BOWL WT. (lbs.)	
						1st Stg.	Add Stg.
6CX	15 3/8	4 3/4	6	10 1/4	5 5/8	76	21
6BX	16 3/4	5	6 7/8	11 5/8	5 7/8	76	21
7DX	17 11/16	4 13/16	7 15/16	12 1/16	6 13/16	76	34
8AX	17 3/8	5	7 1/4	11	7 5/8	79	39
8BX	20 3/8	7 1/4	8	13 3/4	7 3/4	120	42
9BX	21 9/16	6 7/16	9 13/16	14 5/16	8 5/8	147	56
10AX	16	6 1/2	6 3/4	10 3/4	9 5/8	181	83
10BX	23 3/4	8 1/2	11 1/4	17 3/4	9 13/16	193	75
11AX	17 1/8	7 1/4	7 3/8	13 1/8	10 7/8	255	95
11BX	27 11/16	9 7/8	9 5/8	19 7/8	11	300	120
12BX	27 3/8	10 3/4	10 5/8	19 1/4	11 15/16	315	135
12FX	27 1/2	10 1/4	12 1/2	20 3/4	11 3/8	287	113
13AX	20 7/8	8 5/8	8 1/4	15	13 1/16	395	159
14BX	29 1/2	12 1/2	11 3/4	20	14 1/16	425	170
14FX	31 1/2	12	13 3/4	23 1/4	13 5/16	404	156
15FX	29 3/8	13 1/2	10 15/16	17 1/4	14 7/8	518	195
16BX	28 7/16	14 1/4	12 7/16	21 7/8	16 1/32	446	240
16EX	29	13	10 1/2	21 1/2	15 3/8	583	220
16FX	33	14 7/8	11 1/2	20	16	509	187
16GX	63 1/2	14	15 1/2	27 9/16	17 1/2	458	283
20EX	105	19 5/8	10 3/4	28	20	834	516

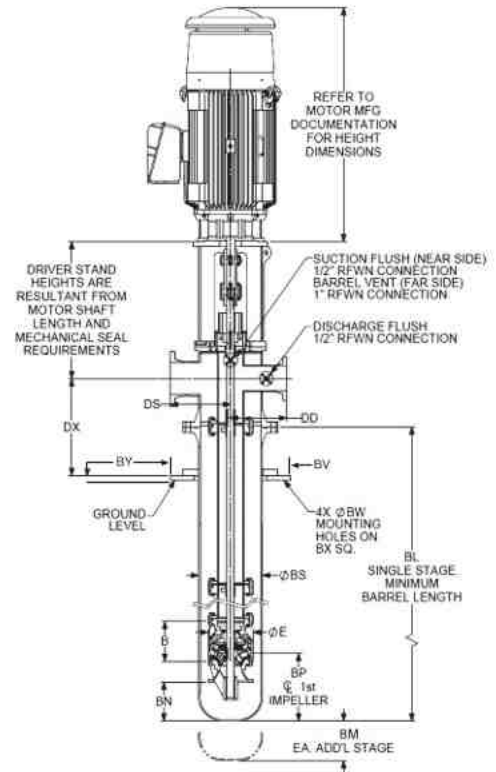

### DISCHARGE HEAD AND SUCTION CAN DIMENSIONS 150# & 300# SERVICE (inches)

DISCH. X SUCTION X	BS	BV	BW	BX	BY	DD	DS	DX	DISCH. HEAD WT. (lbs.)	SUCT. CAN WT. (Lbs.)	
										1st. Ft.	Add. Ft.
3 x 4 x 10	10 3/4	24	1 1/8	20	1	10	11	20	280	249	54
4 x 6 x 12	12 3/4	28	1 1/8	24	1 1/4	12	13	22	410	345	73
6 x 8 x 16	16	32	1 1/4	28	1 1/4	14	15	24	670	552	108
8 x 10 x 20	20	38	1 1/4	32	1 1/2	16	17	26	1050	800	165
10 x 12 x 24	24	44	1 1/4	38	2	20	20	28	1660	1131	237
16 x 20 x 30	30	50	1 3/8	44	2	26	26	34	2745	1601	158

### 600# & 900# SERVICE (inches)

DISCH. X SUCTION X	BS	BV	BW	BX	BY	DD	DS	DX	DISCH. HEAD WT. (lbs.)	SUCT. CAN WT. (Lbs.)	
										1st. Ft.*	Add. Ft.
3 x 4 x 10	10 3/4	28	1 1/8	24	1 1/4	12	12	24	565	513	89
4 x 6 x 12	12 3/4	30	1 1/8	26	1 1/4	13	14	26	850	662	124
6 x 8 x 16	16	34	1 1/4	30	1 1/2	17	18	28	1380	1088	191
8 x 10 x 20	20	40	1 1/4	34	2	20	20	42	2300	1706	295
10 x 12 x 24	24	48	1 1/4	42	2	24	24	46	3860	2775	427
16 X 20 X 30	30	58	1 3/8	52	2	30	30	52	7285	3954	595

### SUCTION BARREL SELECTION (Allowable capacity in USGPM)

NOM. BOWL SIZE (Inches)	BARREL SIZE					
	10	12	16	20	24	30
6	580					
7	450					
8	300	730				
9		560				
10		370	1220			
11			1020	2280		
12			790	2060	3880	
13			550	1810	3640	
14				1550	3370	
15				1260	3090	6030
16				960	2790	5730
20						4320

NOTE: Dimensions shown are considered standard but are not for construction purposes. Discharge heads may be designed to fit most dimensional requirements. Pumps with suction located in the barrel are available. For further information contact the factory. Discharge head dimensions and weights are suitable for 300# ASME flanges. Suction barrel dimensions and weights are suitable for 740 PSI rating.

#### NOTES:

The above capacities are based upon maximum suction inlet velocities of 5 ft./sec.

**BARREL LENGTH ESTIMATION** – Where limited NPSH available and minimum barrel length is insufficient to satisfy pump NPSH requirements the first stage impeller is lowered in the extended length barrel to provide sufficient NPSHR.

To estimate barrel length with customer's NPSH available at grade level. **Example:** 5-stage 10XKH at 3600 RPM; 2 ft. NPSHA at grade level; required capacity – 600 USGPM.

1. NPSHR (req'd) at C<sub>1</sub> 1st. stage impeller (from performance curve) ..... + 18.00 Ft.
2. NPSHA at grade level (specified by customer) ..... - 2.0 Ft.
3. Additional barrel length from C<sub>1</sub> 1st. stage impeller barrel to bottom (BP dimension on this page, convert from inches to feet) ..... + 0.9 Ft.
4. Estimated hydraulic friction losses ..... + 2.0 Ft.
5. Safety factor (pump runout allowance)\* ..... + 2.0 Ft.

**Estimated Barrel Length** ..... 20.9 Ft.

\* Will vary, depending on application.

\*1st 2 Feet on 20" & 24" Barrels

SHORT PANEL DOTTED LINE DOES NOT PRINT

# PWV API 610 VERTICAL TURBINE PUMP

## SOLE PLATE 150# & 300# SERVICE (inches)

SUCTION CAN	BV	BX	BW	BY
10	24	20	1 1/8	1
12	28	24	1 1/8	1 1/4
16	32	28	1 1/4	1 1/4
20	38	32	1 1/4	1 1/2
24	44	38	1 1/4	2
30	50	44	1 3/8	2
36	58	52	1 3/8	2

## SOLE PLATE 600# & 900# SERVICE (inches)

SUCTION CAN	BV	BX	BW	BY
10	28	24	1 1/8	1
12	30	26	1 1/8	1 1/4
16	34	30	1 1/4	1 1/4
20	42	36	1 1/4	1 1/2
24	48	42	1 1/4	2
30	58	52	1 3/8	2
36	66	60	1 3/8	2

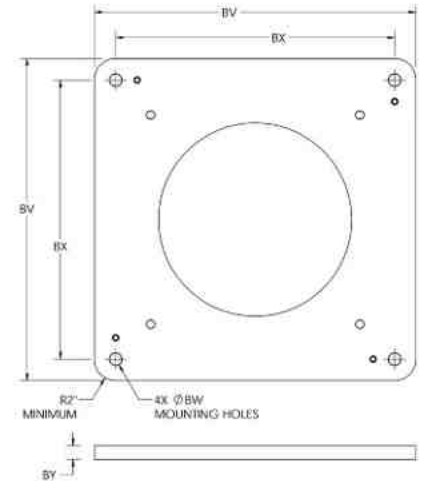

## API 610 Classifications

- Vertical Suspended Single Casing (Sump Type / Wet Pit) VS1
- Vertical Suspended Double Casing (Can Type) VS6

## Typical Services

- Vertical Process
- Light Hydrocarbon, High-Vapor Pressure (Low NPSHA)
- Pipeline Booster
- Offshore Platform/ Sea Water Lift (Crude Oil Transfer)
- LBPB Transfer
- Refinery Service
- Waste Water
- Secondary Recovery
- Cryogenic Liquid
- Cooling Water
- Aircraft Fueling



## Test Facilities Horizontal and Vertical Pumps

A critical function of any pump manufacturer is the performance testing of their product across the pump's operating region to ensure that it meets design specifications. The PumpWorks 610 Pump are designed to provide performance and NPSHR tests in accordance with the latest edition of API 610.



## Test Facilities Capabilities:

- Test flows up to 21,500 gpm
- Discharge test pressures up to 6,000 psi
- Variable frequency drive for precise speed control through 600 HP @ 460 volt
- Solid state soft start for low impact motor starting over 600 HP through 6,000 HP @ 4160 volt

See our PumpWorks 610 Test Facilities Brochure for more information.

