

SINGLE STAGE SPLIT CASE PUMPS

1800 SERIES

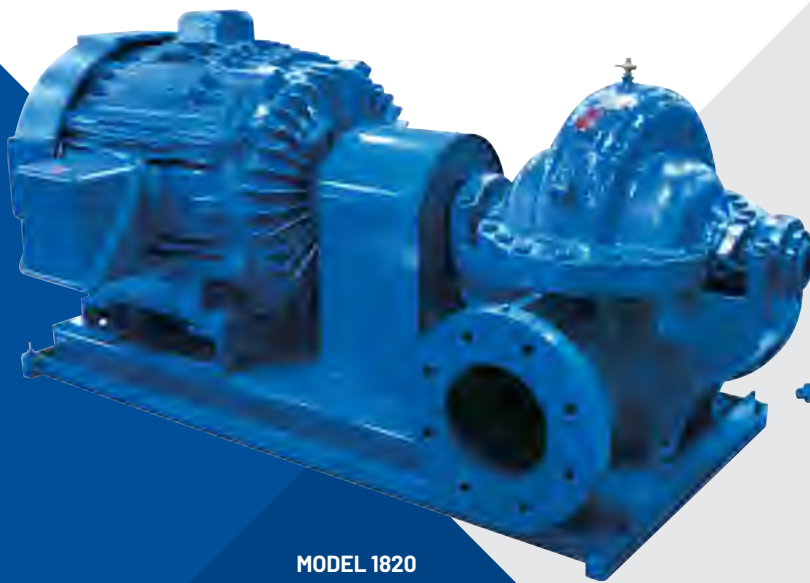

MODEL 1820



MODEL 1840

PENTAIR® FAIRBANKS NIJHUIS® 1800 SERIES SINGLE STAGE SPLIT CASE PUMPS

Capacities to 15000 GPM (3407 m³/hr)

Heads to 663 Ft. (202 m)

Temperatures to 275°F (135°C)

TRUSTED TECHNOLOGY. MODERN DESIGN.

Horizontal split case pumps are a tried-and-true technology that have been trusted for generations to reliably pump water and other low-viscosity fluids in a variety of applications. Their simple design and rugged construction make them ideal for industrial, agricultural, and commercial settings.

Fairbanks Nijhuis 1800 Series Pumps offer a modern contribution to that trusted design. The result is a pump that is best-suited to your specifications, while offering the performance and dependability you expect.

MODEL 1810

Vertically mounted and uses flexible shafting between the driver and pump. Recommended for installations where flooding is possible.

MODEL 1820

Horizontally baseplate mounted with a driver flexibly coupled to the pump. Recommended for installations with ample floorspace and no possibility of flooding.

MODEL 1840

Vertically mounted with an elevated driver coupled directly to the pump through a flexible coupling. Recommended for installations with limited floorspace and marginal possibilities of flooding.

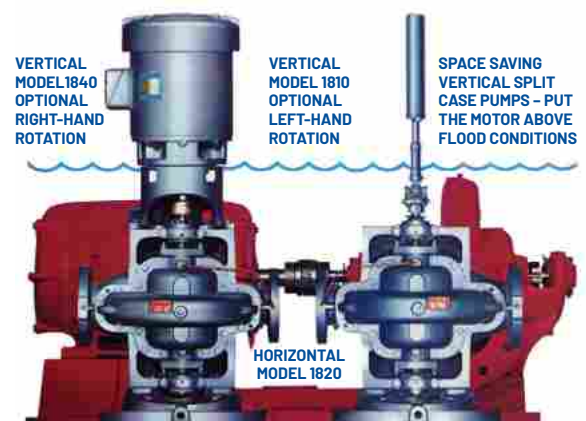

PUMP FEATURES

STANDARD FEATURES

- ◆ Bronze fitted pump construction
- ◆ Bronze shaft sleeves
- ◆ Dynamically balanced impellers
- ◆ Bronze case wearing rings
- ◆ Twin volute on 10" and larger pumps
- ◆ Stainless steel impeller key
- ◆ Regreasable ball bearings
- ◆ Single row ball bearing (inboard)
- ◆ Double row ball bearing (outboard)
- ◆ Mechanical seals, single unbalanced (Models 1810 and 1840)
- ◆ Graphite and TFE lubricated acrylic packing

- ◆ Internal bypass between casing and stuffing box
- ◆ 125# ASA flanges
- ◆ 250 psi case working pressure
- ◆ Carbon steel shaft
- ◆ Stuffing box bushings
- ◆ Lifting lugs
- ◆ Hydrostatic test
- ◆ Cast integral bearing arms
- ◆ Water slingers and grease seals
- ◆ External bypass between casing and stuffing box (Models 1810 and 1840)
- ◆ Coupling guard (Model 1820)

OPTIONAL FEATURES

- ◆ All iron or specialty alloy pump construction
- ◆ Hardened 440C stainless steel shaft sleeves (packing only)
- ◆ 316 stainless steel shaft sleeves (mechanical seal)
- ◆ Impeller wearing rings
- ◆ Oil lubricated ball bearings (Model 1820 horizontal pump)
- ◆ Mechanical seals
 - ◆ Single unbalanced (Model 1820)
 - ◆ Single balanced (all models)

- ◆ Stainless steel or Monel® shaft
- ◆ External bypass between casing and stuffing box (Model 1820)
- ◆ Steel drip rim, formed steel or fabricated steel bases
- ◆ Double extended shaft (Model 1820)
- ◆ Right- or left-hand rotation
- ◆ Certified performance test
- ◆ Packing with lantern ring (Model 1820)
- ◆ 250# ASA suction and discharge flanges
- ◆ Water cooled cartridge caps

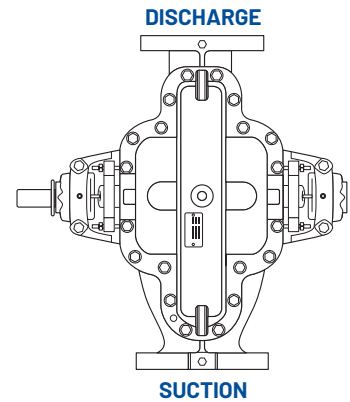

**STANDARD
RIGHT HAND ROTATION**

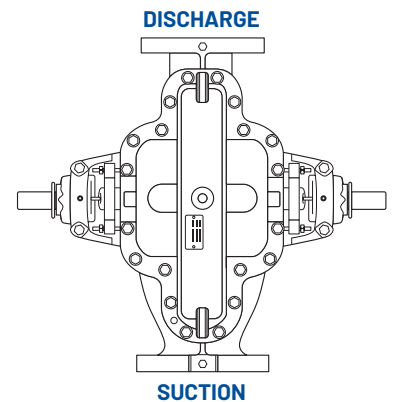

**OPTIONAL DUAL DRIVE
RIGHT HAND ROTATION**

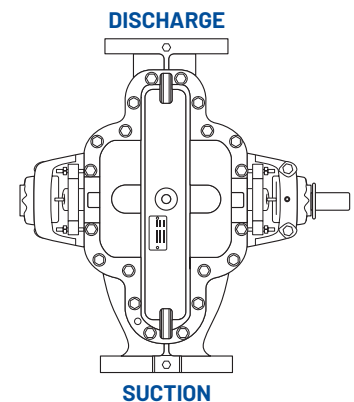

**OPTIONAL
LEFTHAND ROTATION**

HORIZONTAL PUMP FEATURES

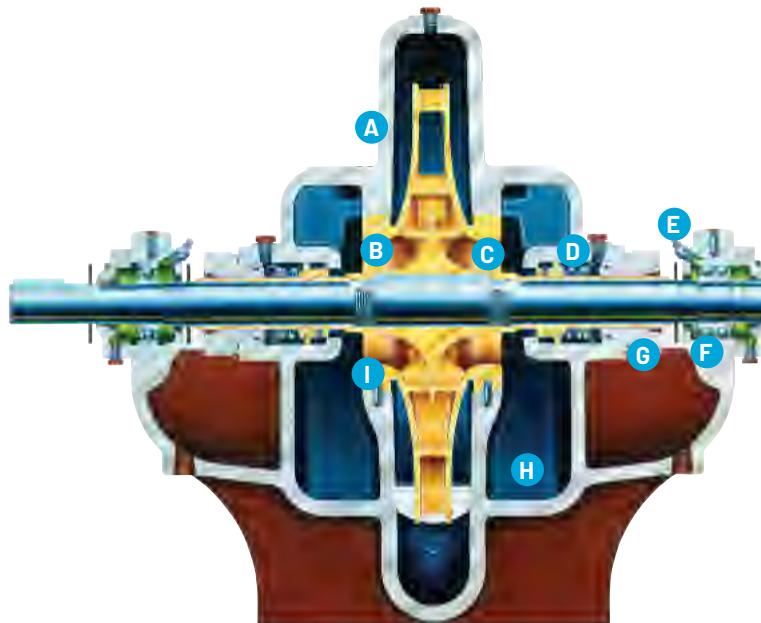

A. SPLIT CASE DESIGN

- ◆ Design makes service or inspection simple by removal of upper casing without disturbing suction and discharge piping and alignment
- ◆ Computer-machined major components with 360-degree registered fits assure concentricity of all parts
- ◆ Twin volute design balances radial hydraulic thrust loads on larger split case pumps (see range charts)

B. DYNAMICALLY BALANCED IMPELLER

- ◆ Keyed to shaft and secured by adjustable shaft sleeves
- ◆ Double suction design balances hydraulic thrust loads
- ◆ Vacuum cast process and proven design provides superior efficiency and performance

C. BRONZE SHAFT SLEEVE

- ◆ Slip fit over the shaft, keylocked and extends the entire length of each stuffing box to prevent shaft wear
- ◆ Shaft sleeves and impeller are O-ring sealed to help reduce likelihood of shaft corrosion, which helps avoid the need for high-cost, special stainless or Monel® shafts.

D. INTERCHANGEABLE STUFFING BOX

- ◆ Allows use of mechanical seals or packing
- ◆ Optional lantern rings with internal water seal passages between the casing and stuffing box to help prevent damage
- ◆ Mechanical seals have carbon against ceramic face
- ◆ 303 stainless steel parts and Buna-N® elastomers help ensure long life
- ◆ Several mechanical seal options available

E. GREASE LUBRICATION

- ◆ Purges old grease from bearing
- ◆ Oil lubrication optional on horizontal pumps
- ◆ Fittings conveniently located provide quick access and positive bearing lubrication
- ◆ Oil seals and nonsparking neoprene rotating slingers protect bearings during operation and washdowns

F. BEARINGS

- ◆ Provide 50,000-hour minimum life at maximum load
- ◆ Double row thrust ball bearing standard on all models
- ◆ Short bearing span holds shaft deflection to .002" at face of stuffing box at maximum load
- ◆ Integral bearing arms help eliminate bearing misalignment and simplify service

G. LEFT-HAND ROTATION

- ◆ Available with standard parts – tandem drive pumps only require a different shaft

H. CERTIFIED PERFORMANCE

- ◆ Certification with positive suction pressure or with a suction lift is available on each pump for customer approval – pumps are all hydrostatically tested

I. CASE WEARING RINGS AND THROTTLE BUSHINGS

- ◆ Prevent wear on the pump casing
- ◆ Easy and cost-effective to replace

VERTICAL PUMP FEATURES

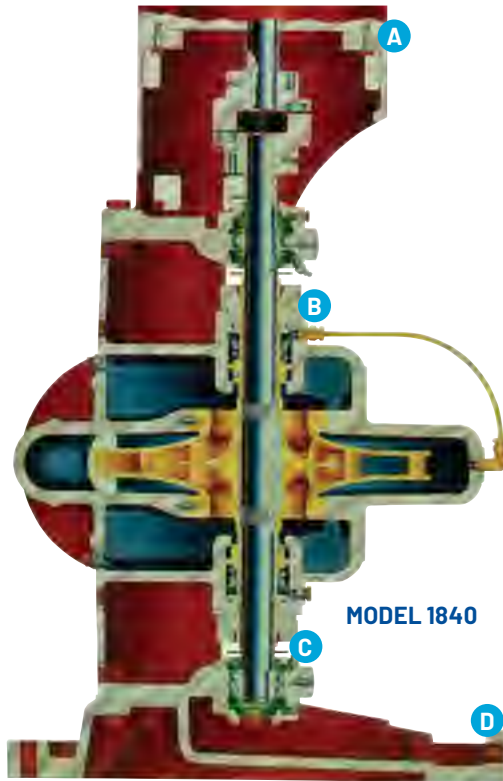

KEY FEATURES

A. COUPLING ALIGNMENT

- ◆ Mounting bracket is rabbet fitted to the motor to help enable long life and proper performance

B. MECHANICAL SEALS

- ◆ Standard construction includes carbon against ceramic face for optimum hot water performance
- ◆ 303 stainless steel parts and Buna-N® elastomers help provide long life

C. BEARING PROTECTION

- ◆ Grease seals and water slingers protect the bearings from contamination (also standard on horizontal pumps)

D. CAST IRON DRIP RIM BASE

- ◆ Mounting base helps assure accurate positioning of the pump
- ◆ Integral drip rim controls condensation and leakage

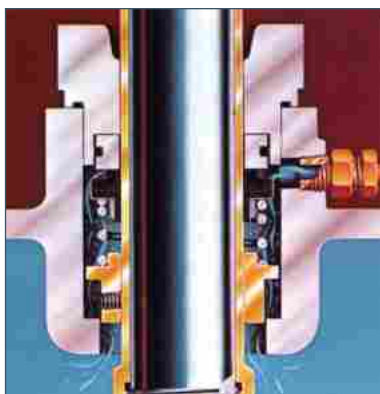

EXTERNAL UPPER SEAL FLUSH

BENEFITS

Vertical pumps allow you to place two pumps where only one horizontal would fit. Pentair Fairbanks Nijhuis Space-Saving Vertical Split Case Pumps are known for their reliability, and the Model 1820 builds on that reputation.

Vertical pumps offer distinct advantages over horizontal pump construction.

- ◆ They require less floor space
- ◆ In-line piping arrangement allows piping in any direction
- ◆ Elevated motor helps protect against potential flooding

RANGE CHARTS

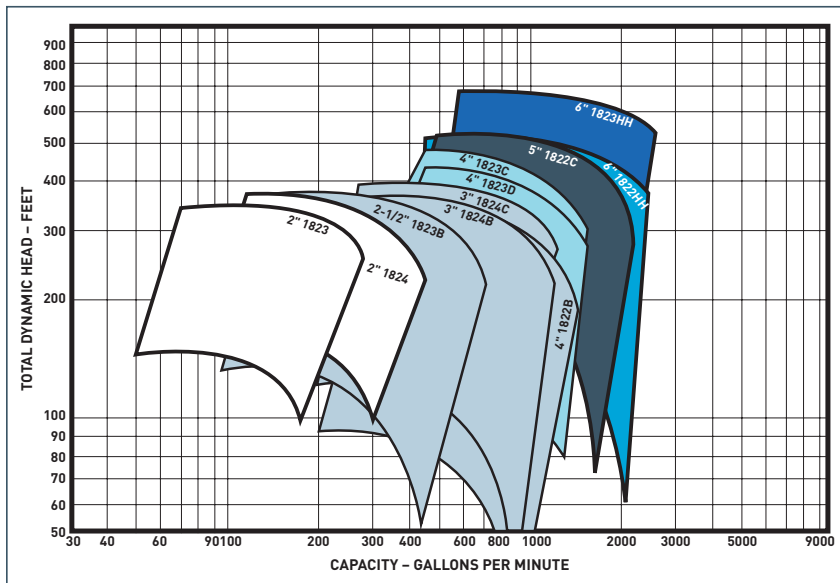

SINGLE VOLUTE 3500 RPM

Individual performance curves should be checked for final selection.

For selections not shown on this chart, please refer to the factory.

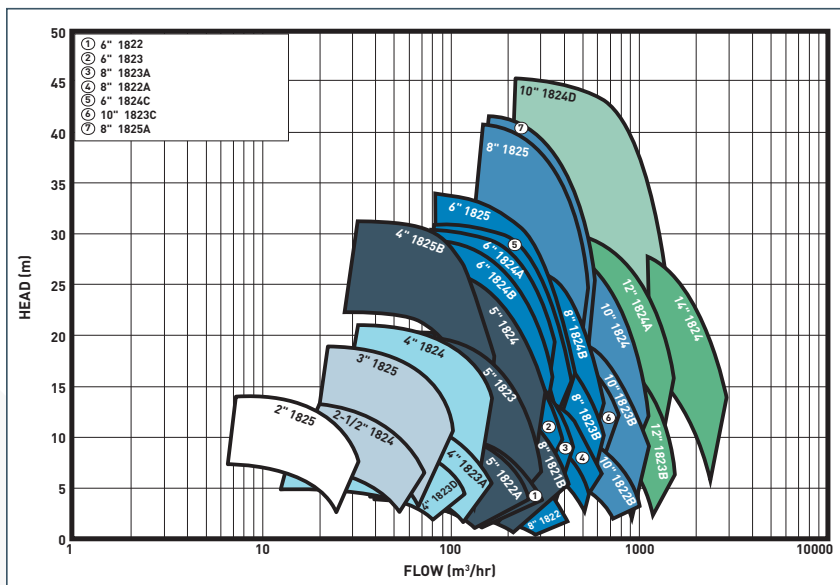
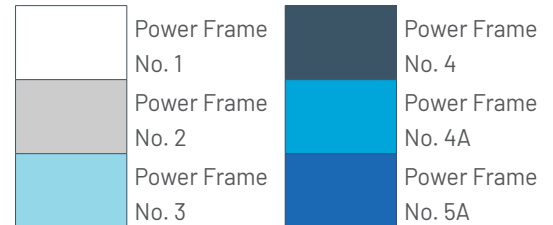

1000 RPM

Individual performance curves should be checked for final selection.

For selections not shown on this chart, please refer to the factory.

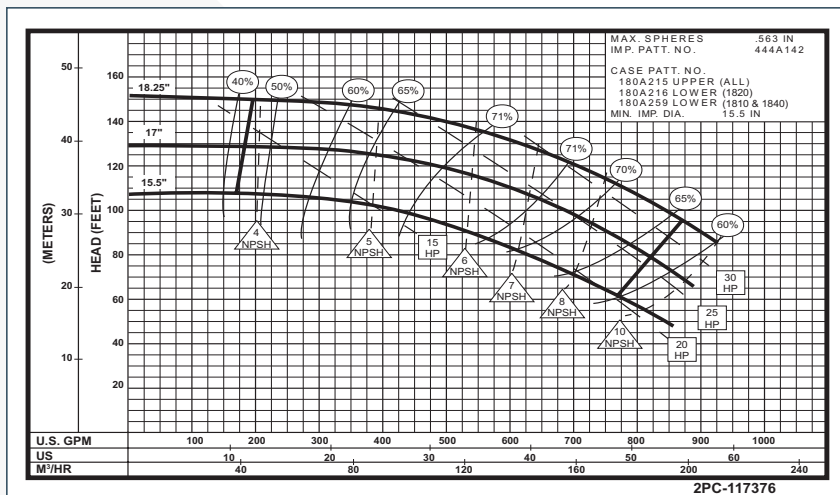
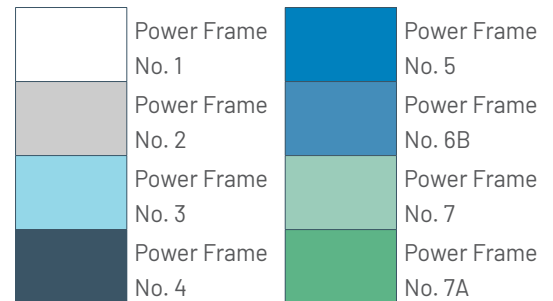

PERFORMANCE CURVES

The individual curve for the size pump selected is found in the catalog. These performance curves give complete operating characteristics, efficiency, horsepower and N.P.S.H. required. Horsepower lines on these curves are based on specific gravity of 1.0. To obtain the horsepower for a liquid of a different specific gravity, multiply the horsepower obtained from the curves by the specific gravity of that liquid. The performance curve illustrated to the left is typical of the individual curves readily available for each pump size.

RANGE CHARTS

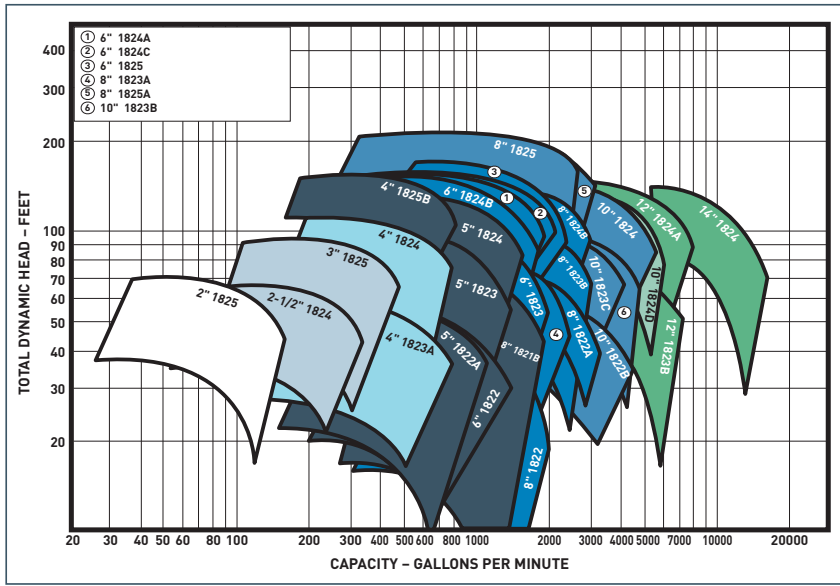

1150 RPM

Individual performance curves should be checked for final selection.

For selections not shown on this chart, please refer to the factory.

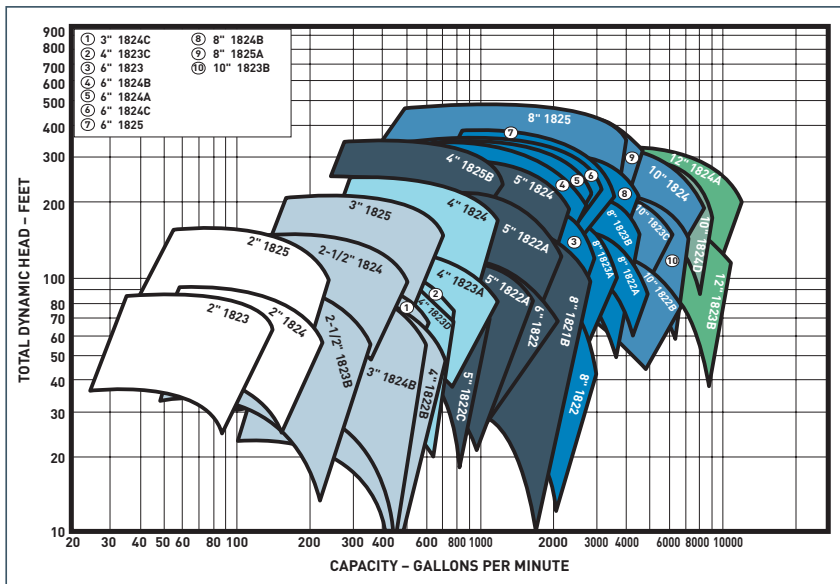
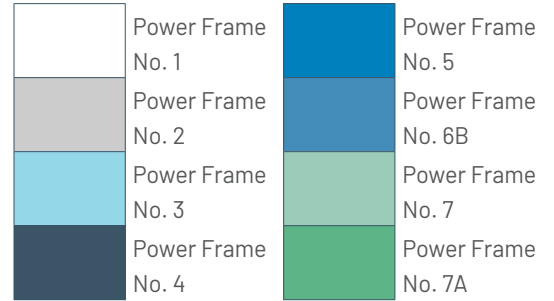

1750 RPM

Individual performance curves should be checked for final selection.

For selections not shown on this chart, please refer to the factory.

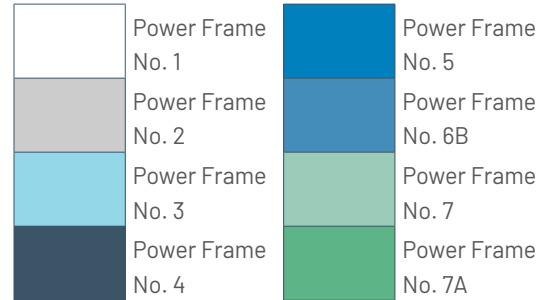

RANGE CHARTS

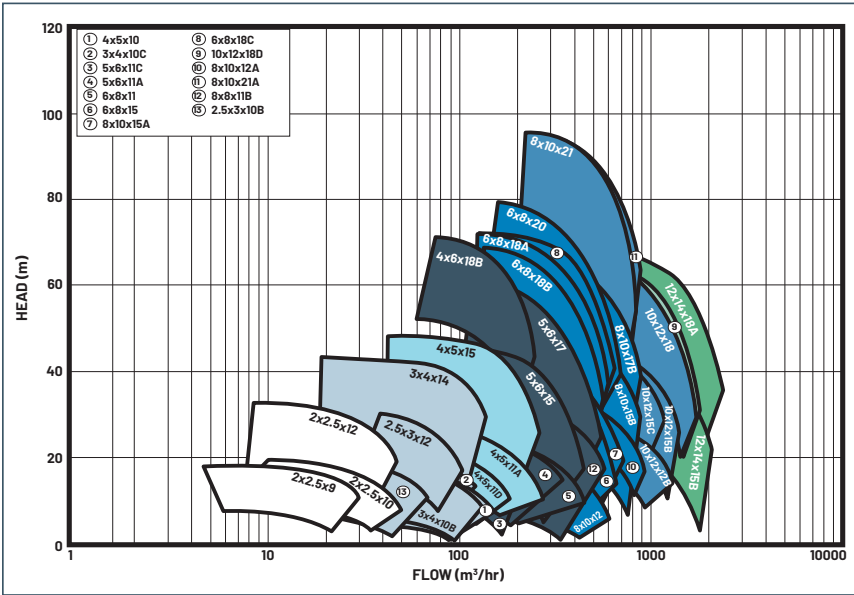

1500 RPM

Individual performance curves should be checked for final selection.

For selections not shown on this chart, please refer to the factory.

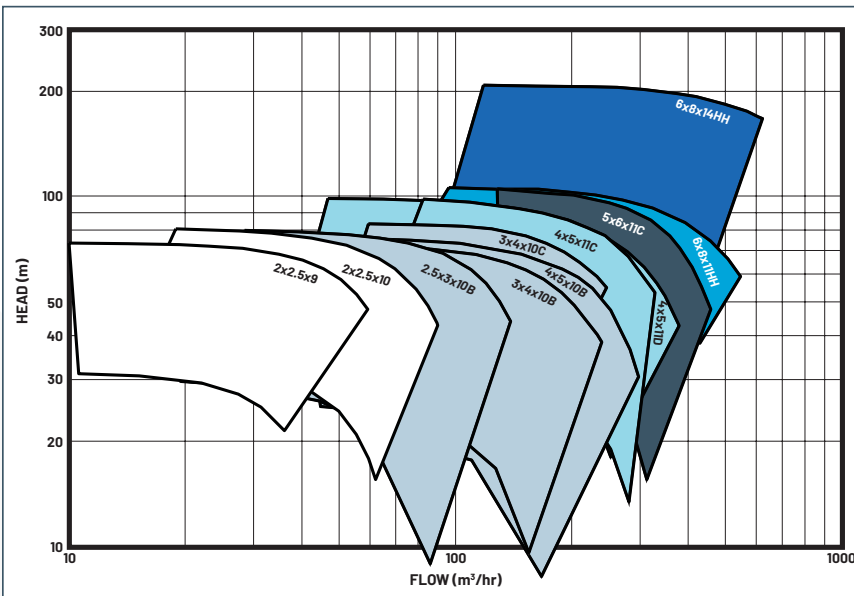
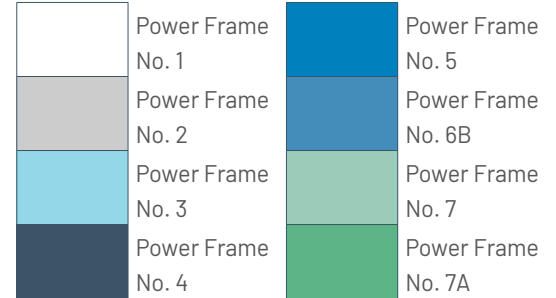

3000 RPM

Individual performance curves should be checked for final selection.

For selections not shown on this chart, please refer to the factory.

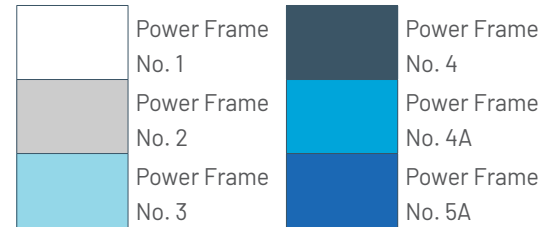

PUMP DIMENSIONS

PUMP SIZE	DISCHARGE	SUCTION	BORE	PWR. SERIES	PUMP WGT. (LBS.)		A	D**	S	X	CP	HY	VE	YY	
					1820	1840									
2x2.5x9	2	2-1/2	9	1	145	215	18	7	3-1/2	8-1/2	21	4-1/2	11-1/8	9	
2x2.5x10	2	2-1/2	10		145	215	18	7	3-1/2	8-1/2	21	4-1/2	11-1/8	9	
2x2.5x12	2	2-1/2	12		175	260	18	8	4	10	21	4-1/2	11-1/8	10-3/4	
2.5x3x10	2-1/2	3	10	2	215	300	18	8	4	9-3/4	24	5-1/2	13	10	
2.5x3x12	2-1/2	3	12		255	360	18	9	4-1/2	11	24	5-1/2	13	11-1/2	
3x4x10	3	4	10		260	365	18	9	4-1/2	10	24	5-1/2	13	11	
3x4x14	3	4	14	3	310	435	18	10	5	12	24	5-1/2	13	13	
4x5x10	4	5	10		330	465	18	9	4-5/8	10	24	5-1/2	13	11-1/4	
4x5x11	4	5	11		390	435	22	10	5	11-1/4	26	6-1/2	14	12-3/4	
4x5x15	4	5	15	4	415	490	22	11	5-1/2	13	26	6-1/2	14	14	
4x6x18	4	6	18		560	780	22	12-1/2	6-1/4	14	29	6-1/2	15	16	
5x6x11	5	6	11		455	580	22	11	5-1/2	11-1/4	29	6-1/2	15	13-1/4	
5x6x15	5	6	15	5	530	735	22	12-1/2	6-1/4	13-1/4	29	6-1/2	15	15	
5x6x17	5	6	17		635	855	22	12-1/2	6-1/4	14	29	6-1/2	15	15	
6x8x11	6	8	11		520	650	22	12-1/2	6-1/4	11-3/4	29	6-1/2	15	14-1/2	
8x8x11	8	8	11	6B	605	835	22	12-1/2	6-1/4	12	29	6-1/2	15	14-1/2	
6x8x11HH	6	8	11HH		4A	990	1095	22	13-3/16	8-5/8	10	32-3/4	8-1/2	17-1/8	15
6x8x14HH	6	8	14HH		5A	1190	1410	30	13-3/16	7-1/2	15	36-3/4	8-1/2	19-7/16	17
6x8x15	6	8	15	7	585	735	30	13-1/2	6-3/4	14-1/4	32	7-1/2	17	16-3/4	
6x8x18	6	8	18		800	1020	30	14-3/4	8	16	32	7-1/2	17	18	
6x8x20	6	8	20		875	1095	30	14-3/4	8	15-3/4	32	7-1/2	17	18	
8x10x12	8	10	12	6B	740	925	30	14-3/4	8*	17	32	7-1/2	17	17-3/4	
8x10x15	8	10	15		835	1040	30	14-3/4	8*	17	32	7-1/2	17	17-3/4	
8x10x17	8	10	17		865	1085	30	14-3/4	8	17	32	7-1/2	17	17-3/4	
8x10x21	8	10	21	7	955	††	††	18-1/2	9-1/2	18	38	11-1/2	-	21	
10x12x12	10	12	12		1325	1575	40	23	12	16	38	11-1/2	-	19	
10x12x15	10	12	15		1390	††	††	25	13-1/2	17	38	11-1/2	-	20	
10x12x18	10	12	18	7A	1725	††	††	25	13-1/2	18	38	11-1/2	-	22	
10x12x18D	10	12	18D		1920	††	††	25	12-1/4	20	42-15/16	11-1/2	-	24	
12x14x15	12	14	15		2000	††	††	24	15	17	44	11-1/2	-	22	
12x14x18	12	14	18	7	2100	††	††	24	15	18	44	-	-	23	
14x16x18	14	16	18		2850	††	††	29-1/4	16	22	44	-	-	27	

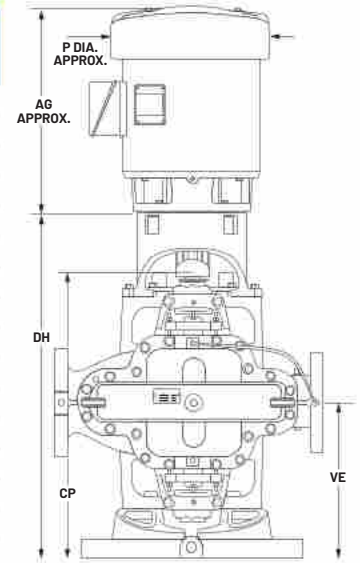

MODELS 1810 AND 1840

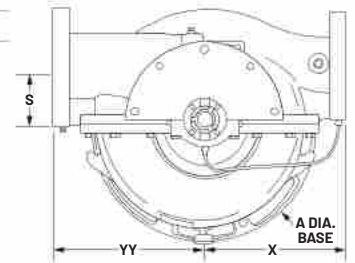
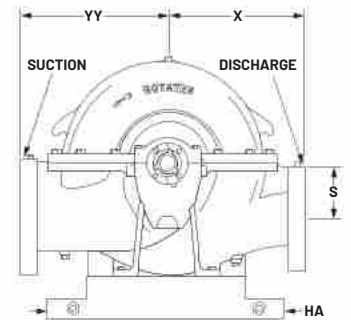

MODEL 1820

MODELS 1810 AND 1840

PWR. SERIES		1	2	3	4	5
DH	Up to 256 hp	26	30	33	35	-
	284 hph and up	28	32	35	37	41
CP		23	27	29	31	35

NOTES - APPLY TO ALL MODELS:

- * Add 1" for true discharge centerline.
- ** Always use largest of 2 "D" dimensions.
- †† These pump sizes are available in a vertical chair mount configuration in Models 1810 and 1840. See individual dimensions pages for complete dimensions and weights.

ENGINEERING SPECIFICATIONS

MODELS 1810, 1820, AND 1840 SPLIT CASE BASE MOUNTED

Furnish and install as shown on the plans ____ Right-hand (Left-hand) Pentair Fairbanks Nijhuis Model (Horizontal - 1820) (Vertical - 1810 Open Shaft)(Vertical - 1840 Flexible Coupled) type Split Case, Double Suction, Single Stage centrifugal pump, size ____x____x____ of bronze fitted (all bronze)(all iron)(stainless steel) construction. The pump shall be capable of delivering at design conditions a capacity of ____ GPM when operating against a Total Dynamic Head of ____ feet, with a temperature of ____ °F, specific gravity _____. Pump shall have minimum guaranteed efficiency at design capacity of ____%. Pump must also be capable of delivering a maximum of ____ GPM when operating against a head of ____ feet, and at this condition shall have a minimum efficiency of ____%. Minimum shut-off head acceptable will be ____ feet. Pump shall operate at a maximum synchronous speed of ____ RPM.

A unit operating at a lesser rotative speed will be considered, but in no event will a pump operating at more than the maximum speed specified be acceptable. The pump casing halves shall be of the inline piping design and will be constructed of Class 30 cast iron having a minimum tensile strength of 30,000 psi and shall be of sufficient thickness to withstand stresses and strains at full operating pressures.

Casings shall be subject to a hydrostatic pressure test at 150% of the specified duty point. Bearing housing supports, suction and discharge flanges shall be integrally cast with the lower half of the casing. Removal of the upper half of the casing must allow the rotating element to be removed without disconnecting the suction and discharge flanges. The upper casing is to be dowel aligned to the lower casing.

Pump sizes 10" and larger are to be of the twin volute design. Drain openings must be provided in the bearing arms for removal of lubricating liquid. Impeller shall be of the enclosed double suction

type and shall be vacuum cast bronze (____). Impeller shall be dynamically balanced and securely fastened to the shaft by key and screw locked shaft sleeves. The vanes shall be designed to reduce noise. The pump shaft shall be made of high grade SAE 1045 steel or equal, accurately machined to give a true running rotating element. The minimum dia. acceptable will be ____". The shaft shall be protected from wear by bronze (____) sleeves which are key locked and threaded so that the sleeves tighten with the rotation of the shaft. Buna® O-rings must be provided between the impeller hub and the shaft sleeves to prevent pumped liquid from corroding the shaft.

Pump shall be equipped with easily renewable bronze (____) casing rings (impeller wearing rings) so designed that hydraulic pressure will seat them against a shoulder in the pump case around the full periphery of the wearing ring. The wear rings will be locked in place by the doweling to prevent rotation. The rotating element shall be mounted in heavy duty grease lubricated ball bearings and shall be equipped with water strainers on side next to pump glands.

Bearing housings shall be so designed to flush lubricant through and provide continuous cleaning of bearing surfaces and protection against overheating. The pump shall be supplied with a single row inboard bearing primarily for radial loads and double row outboard bearing primarily for thrust loads. Both bearings shall be regreaseable lubrication ball type, designed for 50,000 hours average life. Each bearing shall be mounted in a machined housing that is moisture- and dust-proof. The housing shall have registered fits to assure alignment, pinned to prevent rotation and bolted to the bearing arms. Each housing shall be supplied with a grease fitting and a plugged relief port.

ENGINEERING SPECIFICATIONS

MODEL 1820

Stuffing boxes shall be placed on both sides of the pump centerline to seal the pump shaft. All packed pumps having a suction lift shall be provided with lantern rings connected to the pressure side of the pump by cored passages in the parting flange of the pump. The stuffing boxes shall be equipped with heavy, cast, split glands with extra length, for easy removal for packing inspection and maintenance. Pump and motor shall be mounted on a common heavy baseplate of (steel with drip rim)(formed steel)(structural steel). Pump and motor must be checked for alignment after the pump base has been installed and grouted in place, in accordance with the standards of the Hydraulic Institute. There shall be no strain transmitted to the pumps.

MODELS 1810 AND 1840

Mechanical seal boxes shall be placed on both sides of the pump centerline to seal the pump shaft. Each pump is to be furnished with mechanical seals with all metal parts to be 303 stainless steel with Buna-N® elastomers, ceramic seat, and carbon washer. A bypass line must be provided for the upper seal between the seal faces and the discharge flange to assure adequate venting of the seal chamber and to provide lubrication. All pumps shall be provided with cored passages in the parting flange of the pump to provide additional circulation to both seals. The mechanical seal boxes shall be equipped with heavy, cast, one piece O-ring sealed glands. The pump shall be supported by a cast iron drip rim base.

MODEL 1810

Vertical open shaft pumps are to be driven through flexible shafting with dia. tubing and intermediate bearings. Shafting must be of sufficient size to transmit required HP and must be provided with a slip spline which will permit removal of the pump rotating assembly without removing any section of intermediate shafting, bearings, suction or discharge piping.

MODEL 1840

Vertical flexible coupled pumps shall be furnished with a cast iron motor bracket which is to be bolted to the vertical casing. The motor bracket must be machined with a register fit to ensure proper alignment of motor and pump shaft.

MODELS 1820 AND 1840

The pumps shall be flexible coupled to a standard (horizontal) (vertical) NEMA®, ___ hp, ___ phase, ___ hertz, ___ volts, ___ RPM (drip-proof)(tot. encl.)(hazardous location) motor.



3601 Fairbanks Avenue | Kansas City, KS 66106 | Ph: 913.371.5500 | pentair.com

All indicated Pentair trademarks and logos are property of Pentair. Third party registered and unregistered trademarks and logos are the property of their respective owners. Because we are continuously improving our products and services, Pentair reserves the right to change specifications without prior notice. Pentair is an equal opportunity employer.

Buna N® is the registered trademark of Pittway Corporation, Chicago.

Hydraulic Institute is a trademark of Hydraulic Institute, Inc.

Monel is a registered trademark of Special Metals Corporation.

NEMA® is the registered trademark and service mark of the National Electrical Manufacturers Association.

©2022 Pentair. All Rights Reserved.

FM-02-1525 (03-30-22)