

acciaio inox microfuso - elevato rendimento - casted stainless steel - high efficiency

PANELLI®

italian excellence since 1906

6" 8"

140 RSX - 180 RSX | **50Hz**

**POMPA SOMMERSA
RADIALE INOX
RADIAL SUBMERSIBLE
PUMP - INOX**



MADE IN ITALY

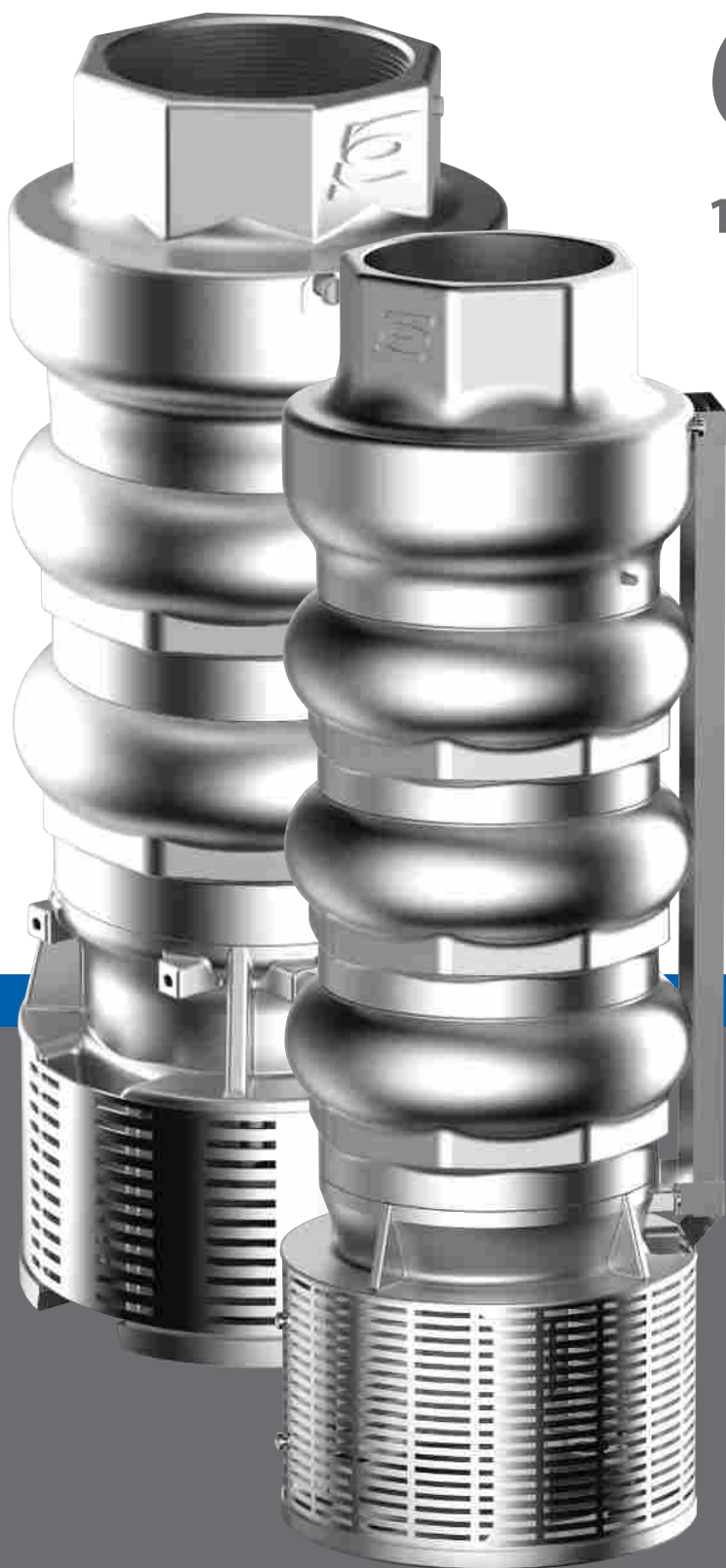

6" - 8" RSX - 1



6" 8" 140 RSX | **50**Hz
180 RSX

POMPA SOMMERSA RADIALE INOX
RADIAL SUBMERSIBLE PUMP - INOX



Pompa radiale in acciaio inossidabile microfuso

Casted stainless steel radial pump

Pompe radiale en acier inoxydable - coulé

Bomba radial en acero inoxidable microfundido

Disponibile su richiesta in: AISI 316 - Duplex

Available on request in: AISI 316 - Duplex

Disponibile sur demanden: AISI 316 - Duplex

Disponibilidad bajo pedido en: AISI 316 - Duplex

PANELLI®

italian excellence since 1906

Tolleranza alla sabbia 100 g/m³ - sand tolerance 50 g/m³
Tolleranze secondo UNI ISO 9906 livello 3B - Tolerances according to UNI ISO 9906 grade 3B

6" - 8" RSX - 2

acciaio inox microfuso - elevato rendimento - casted stainless steel - high efficiency

PANELLI®

italian excellence since 1906

6" 8" 140 RSX | 50Hz
180 RSX

POMPA SOMMERSA RADIALE INOX
RADIAL SUBMERSIBLE PUMP - INOX



Diffusore in acciaio inossidabile AISI 304 microfuso

Casted stainless steel diffuser AISI 304

Diffuseur en acier inoxydable coulé AISI 304

Difusor en acero inoxidable microfundido AISI 304

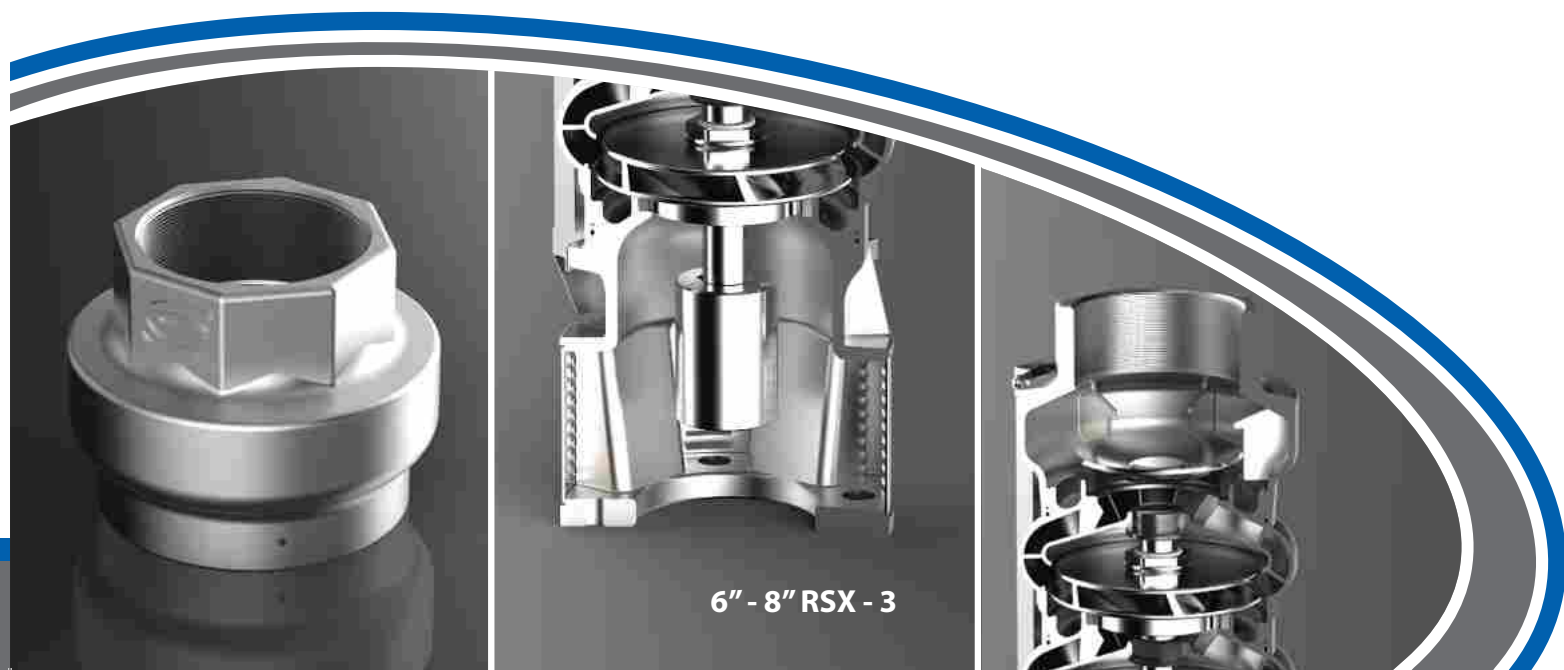

6" - 8" RSX - 3



italian excellence since 1906

6" 8" 140 RSX | 50Hz
180 RSX

POMPA SOMMERSA RADIALE INOX
RADIAL SUBMERSIBLE PUMP - INOX 



ELETTROPOMPE SOMMERSE RADIALI 6"/8" - SERIE 140 E 180 RSX IN ACCIAIO MICROFUSO EN 1.4301(AISI 304)

Le pompe radiali della gamma RSX, sono completamente in Acciaio Inossidabile microfuso EN 1.4301(AISI304) e rappresentano la soluzione più evoluta e performante della gamma RX.

La soluzione radiale avendo un ingombro assiale particolarmente ridotto permette l'impiego di un elevato numero di stadi, con la conseguenza di ottenere a parità di diametro prevalenze molto elevate.

Il diffusore, grazie al sistema di palettatura prolungata fino all'uscita della girante, consente all'acqua di seguire una traiettoria obbligata con conseguente aumento delle prestazioni e del rendimento idraulico.

Lo stadio è composto da: Girante, Diffusore, Cono e ghiera, Bronzina intermedia, Anello di usura, O-ring

In questo tipo di pompa le giranti sono fissate all'albero pompa tramite il cono e la ghiera, evitando quindi il taglio chiavetta e il relativo indebolimento dell'albero. Il corpo diffusore è bloccato l'uno con l'altro, tramite un sistema di filettatura, eliminando quindi i tiranti che durante il funzionamento, possono allungarsi e/o snervarsi con possibili perdite di acqua tra gli stadi.

VANTAGGI

Elevato rendimento – bassi costi di esercizio, notevole durata nel tempo, facilità di montaggio e smontaggio, pressioni elevate ridotta manutenzione

MATERIALI

Diffusore, gabbia di aspirazione e corpo valvola in acciaio inox microfuso EN 1.4301 (AISI 304)

Albero pompa in acciaio inox EN 1.4301 (AISI 304)

Bronzine, anelli di usura, guarnizione valvola in gomma NBR.

Disponibile su richiesta :

Acciaio inox microfuso en 1.4401 - AISI 316, Acciaio inox microfuso en 1.4462 – Duplex

CAMPI DI PRESTAZIONE IDRAULICHE

Portate Fino a 78 m³/h, Prevalenze fino a 650 m, Potenze fino a 92 kW, Massima quantità di sabbia ammessa: 100 g/m³



SUBMERSIBLE PUMPS RADIAL 6"/8" Series 140 and 180 RSX In Stainless Steel Precision Casting EN 1.4301 (AISI 304)

The Radial Pumps of RSX range, are completely in Precision Cast Stainless Steel. EN 1.4301(AISI 304) and represent the most advanced and performing solution of the RX range. The radial solution, having a particularly reduced axial size, allows the use of a large number of stage, with the vantage to obtaining very high heads at the same diameter.

The diffuser, thank to the blading system prolonged until the impeller exits, allows the water to follow an obligatory trajectory with a consequent increase in performance and hydraulic performance.

The Stage is composed of:

Impeller, Diffuser, Cone/hexagonal ring, Bearing bush, Usury ring, O-ring

In this type of pump, the Impellers are attached to the pump shaft trough the cone and the hexagonal ring, avoiding therefore, the key cut and no fault shaft. The diffuser body is stuck with each other, via a threading system, thus eliminating the pulls that during operation can stretch with possible water leaks between the stages.

ADVANTAGES

High performance – Low operating costs, Remarkable durability, Easy mounting and disassembling, High pressure, Reduced maintenance

MATERIALS

Diffuser, suction and body valve in Stainless Steel precision casted EN 1.4301 (AISI 304), Pump shaft in Stainless Steel EN 1.4301(AISI 304), Bearing bush, usury ring, valve gasket in NBR.

Under request:

Stainless steel precision casted EN 1.4401 – AISI 316

Stainless steel precision casted EN 1.4462 – DUPLEX.

HYDRAULIC PERFORMANCES

Flow up to 78 m³/h, Head up to 650 mts., Power up to 92 kW, Max sand permitted : 100 g/m³

Tolleranza alla sabbia 100 g/m³ - sand tolerance 100 g/m³ - MEI ≥ 0,4 (direttiva EU No. 547/2012 - regulation EU N. 547/2012)

Tolleranze secondo UNI ISO 9906 livello 3B - Tolerances according to UNI ISO 9906 grade 3B



italian excellence since 1906

6" 8" 140 RSX | 180 RSX | 50Hz

POMPA SOMMERSA RADIALE INOX
RADIAL SUBMERSIBLE PUMP - INOX



POMPES IMMERGÉES RADIALES 6"/8" – SERIE 140 ET 180 RSX EN ACIER INOXIDABLE (AISI 304) ET MICROFUSION EN 1.4301

Les pompes immergées radiales de la série RSX sont totalement en acier inoxydable et microfusion EN 1.4301 (AISI 304) et elles représentent la solution plus avancée et performante de la série RX.

La solution radiale permet l'utilisation d'un grand nombre d'étages grâce à ses dimensions axiales réduites et en conséquence on peut obtenir des performances plus élevées avec le même diamètre.

Grâce au système dans lequel les palettes sont longues jusqu'à la sortie de la roue, le diffuseur permet à l'eau de suivre une trajectoire oblique avec une augmentation des performances et de l'efficacité hydraulique.

L'étage est composé de :

Roue, diffuseur, Cône et bague, Coussinet intermédiaire, Bague d'usure, O-ring

Dans ce type de pompe, les roues sont fixées à l'arbre de la pompe à travers le cône et la bague, évitant ainsi de faire logement de la clé et l'affaiblissement relatif de l'arbre. Le corps diffuseur est bloqué l'un contre l'autre à travers un système d'enfilage et avec l'élimination des tirants qui, durant l'opération, peuvent s'étirer et/ou devenir gênants avec des éventuelles fuites d'eau entre les étages.

ADVANTAGES

Haute efficacité, coûts d'exercice réduits, durée de vie importante, facilité de montage et démontage, hautes pressions, manutention réduite

MATERIAUX

Diffuseur, cage d'aspiration et refoulement en acier inox en coulé EN 1.4301 (AISI 304)

Axe de la pompe en acier inox EN 1.4301 (AISI 304)

Bagues, bagues d'usure, anneau du clapet en caoutchouc NBR

Disponible sur demande

Acier inox en coulé EN 1.4401 - AISI 316

Acier inox en coulé EN 1.4462 - Duplex

PERFORMANCES HYDRAULIQUES

Débit jusqu'à 78 m³/h, hauteur jusqu'à 650 mt, puissance jusqu'à 92 kw, tolérance maximum de sable : 100 g/m³



BOMBAS SUBMERSA RADIALES 6"/8" Serie 140 y 180 RSX en Acero Inoxidable Micro Fundido EN 1.4301 (AISI 304)

Las Bombas Radiales de la serie RSX, completamente en Acero Inoxidable Micro Fundido EN 1.4301 (AISI 304) representan la solución mas avanzada y eficiente de la gama RX.

La solución radial, que tiene una dimensiones axiales particularmente reducidas, permite el uso de un gran numero de etapas, con la consecuencia de obtener presiones muy importante aunque con el mismo diámetro.

El difusor, gracias al Sistema de alave prolongado hasta el final de la salida del impulsor, permite al agua de seguir una trayectoria obligada que tiene como consecuencia un aumento de las prestaciones y de la eficiencia hidráulica.

El estadio está formado por:

Impulsor, Difusor, Cono/hexagonal, Cojinete, Anillo de desgaste, Anillo torico

VENTAJAS

Elevados rendimientos – Bajos costos de trabajo, muy buena durabilidad en el tiempo, fácil de armar y desarmar presiones elevadas, bajo costos de mantenimiento

MATERIALES

Diffusor, succion e impulsion en Acero Inoxidable EN 1.4301 (AISI 304), eje bomba en Acero Inoxidable EN 1.4301 (AISI 304), casquillo de cojinete, anillo de desgaste, junta de válvula en NBR.

Bajo pedido:

Acero Inox microfundido EN 1.4401 – AISI 316, fundición de precisión de acero inoxidable EN 1.4462 – Duplex.

PRESTACIONES HIDRAULICAS

Caudal hasta 78 m³/h, MCA hasta 650 mts., Potencias hasta 92 kW, Maxima arena permitida : 100 g/m³



Tolleranza alla sabbia 100 g/m³ - sand tolerance 100 g/m³ - MEI ≥ 0,4 (direttiva EU No. 547/2012 - regulation EU N. 547/2012)
Tolleranze secondo UNI ISO 9906 livello 3B - Tolerances according to UNI ISO 9906 grade 3B

acciaio inox microfuso - elevato rendimento - casted stainless steel - high efficiency

6"

140 RSX15

PANELLI®

CARATTERISTICHE IDRAULICHE - HYDRAULIC PERFORMANCES

Q= Portata - Capacity - Debit

50 Hz n= 2900 min

Tipo Type	Power		H(m)	0	100	150	200	250	300	350		
	kW	HP		l/min	l/sec	m ³ /h	l/min	l/sec	m ³ /h	l/min	l/sec	m ³ /h
				0	0	0	0	0	0	0	0	0
140 RSX 15/01	0,75	1	15	14	14	13	12	10	9			
140 RSX 15/02	1,5	2	29	28	27	25	23	20	17			
140 RSX 15/03	2,2	3	44	42	41	38	35	31	26			
140 RSX 15/04	3	4	58	56	54	50	46	41	34			
140 RSX 15/05	4	5,5	73	70	68	63	58	51	43			
140 RSX 15/06	5,5	7,5	87	84	81	75	69	61	51			
140 RSX 15/07	5,5	7,5	102	98	95	88	81	71	60			
140 RSX 15/08	7,5	10	116	112	108	100	92	82	68			
140 RSX 15/09	7,5	10	131	126	122	113	104	92	77			
140 RSX 15/10	7,5	10	145	140	135	125	115	102	85			
140 RSX 15/11	9,2	12,5	160	154	149	138	127	112	94			
140 RSX 15/12	9,2	12,5	174	168	162	150	138	122	102			
140 RSX 15/13	11	15	189	182	176	163	150	133	111			
140 RSX 15/14	11	15	203	196	189	175	161	143	119			
140 RSX 15/15	11	15	218	210	203	188	173	153	128			
140 RSX 15/16	13	17,5	232	224	216	200	184	163	136			
140 RSX 15/17	13	17,5	247	238	230	213	196	173	145			
140 RSX 15/18	13	17,5	261	252	243	225	207	184	153			

DIMENSIONI D'INGOMBRO E PESI - OVERALL DIMENSIONS AND WEIGHTS

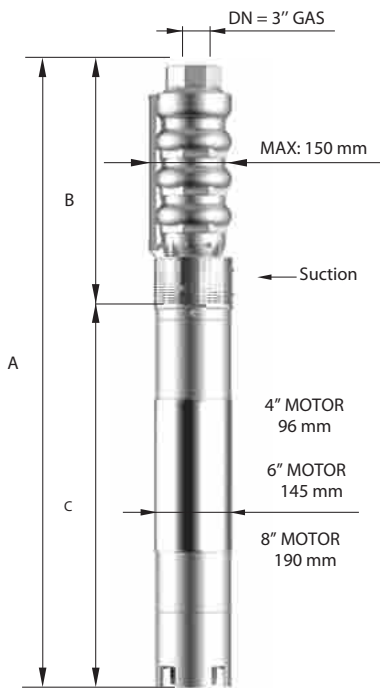

Type	A mm Tri V 400	B mm	C mm Tri	M Kg Tri	P Kg
140 RSX 15/01	639	302	337	10	10
140 RSX 15/02	761	369	392	13	14
140 RSX 15/03	888	436	452	15	17
140 RSX 15/04	1060	503	557	19	21
140 RSX 15/05	1167	570	597	22	25
140 RSX 15/06	1335	637	698	27	28
140 RSX 15/07	1402	704	698	27	32
140 RSX 15/08	1472	771	701	55	35
140 RSX 15/09	1539	838	701	55	39
140 RSX 15/10	1606	905	701	55	43
140 RSX 15/11	1723	972	751	60	46
140 RSX 15/12	1790	1039	751	60	50
140 RSX 15/13	1917	1106	811	65	53
140 RSX 15/14	1984	1173	811	65	57
140 RSX 15/15	2051	1240	811	65	61
140 RSX 15/16	2148	1307	841	70	64
140 RSX 15/17	2215	1374	841	70	68
140 RSX 15/18	2282	1441	841	70	71

n% = Rendimento della pompa
 n% = Rendement de la pompe
 n% = Pump efficiency
 n% = Rendimiento de la bomba

**Max
71%**

kW/st = Assorbimento per stadio
 kW/st = Absorption par étage
 kW/st = Stage absorption
 kW/st = Potencia absorbida por etapa

**Max
0,74**

Tolleranza alla sabbia 100 g/m³ - Sand tolerance 100 g/m³ - Compatibilità con acqua potabile DM 174 Drinking water compatibility according to DM 174
 Tolleranze secondo UNI ISO 9906 livello 3B - Tolerances according to UNI ISO 9906 grade 3B

acciaio inox microfuso - elevato rendimento - casted stainless steel - high efficiency



6"

140 RSX15

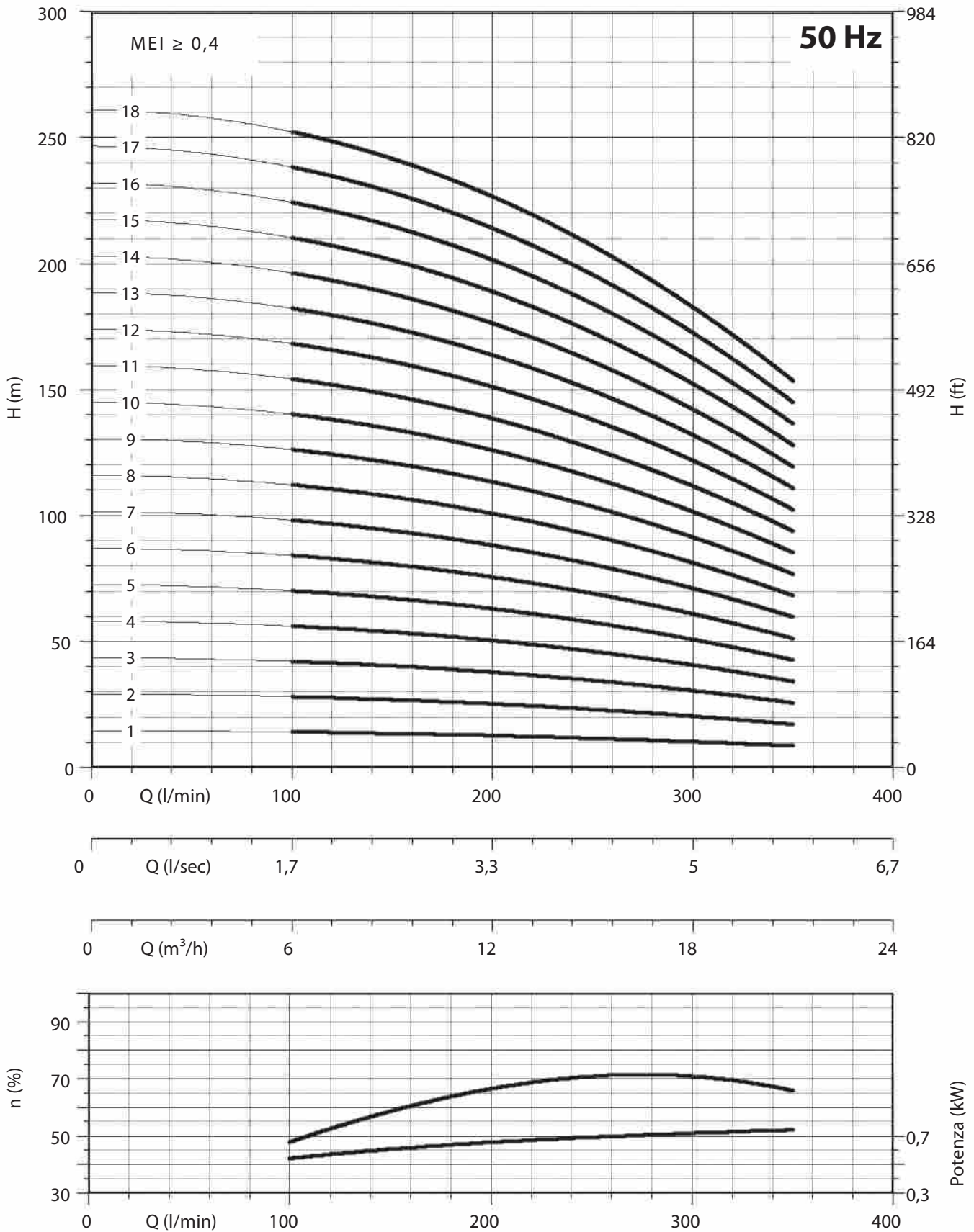

NPSH (m)	25%	50%	75%	100%
140 RSX 15	3	3	4	6

acciaio inox microfuso - elevato rendimento - casted stainless steel - high efficiency

6"

140 RSX15

PANELLI®

CARATTERISTICHE IDRAULICHE - HYDRAULIC PERFORMANCES

Q= Portata - Capacity - Debit

50 Hz n= 2900 min

Tipo Type	Power		H(m)	0	100	150	200	250	300	350			
	kW	HP		l/min	l/sec	m ³ /h	0	1,67	2,5	3,33	4,17	5	5,83
				0	6	9	12	15	18	21			
140 RSX 15/19	15	20	276	266	257	238	219	194	162				
140 RSX 15/20	15	20	290	280	270	250	230	204	170				
140 RSX 15/21	18,5	25	305	294	284	263	242	215	179				
140 RSX 15/22	18,5	25	319	308	297	275	253	225	187				
140 RSX 15/23	18,5	25	334	322	311	288	265	235	196				
140 RSX 15/24	18,5	25	348	336	324	300	276	245	204				
140 RSX 15/25	18,5	25	363	350	338	313	288	256	213				
140 RSX 15/26	22	30	377	364	351	325	299	266	221				
140 RSX 15/27	22	30	392	378	365	338	311	276	230				
140 RSX 15/28	22	30	406	392	378	350	322	286	238				
140 RSX 15/29	22	30	421	406	392	363	334	296	247				
140 RSX 15/30	22	30	435	420	405	375	345	307	255				
140 RSX 15/31	26	35	450	434	419	388	357	317	264				
140 RSX 15/32	26	35	464	448	432	400	368	327	272				
140 RSX 15/33	26	35	479	462	446	413	380	337	281				
140 RSX 15/34	26	35	493	476	459	425	391	348	289				
140 RSX 15/35	26	35	508	490	473	438	403	358	298				

DIMENSIONI D'INGOMBRO E PESI - OVERALL DIMENSIONS AND WEIGHTS

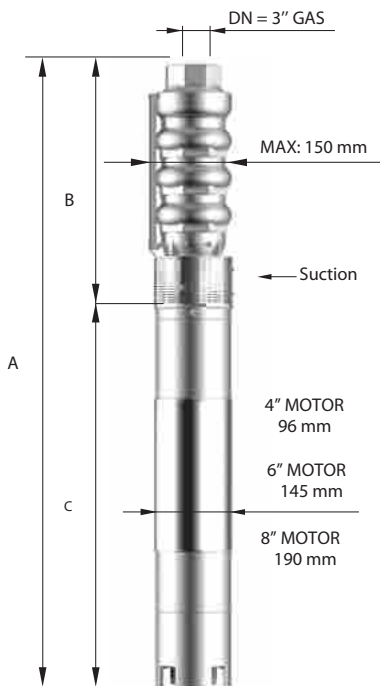

Type	A mm Tri V 400	B mm	C mm Tri	M Kg Tri	P Kg
140 RSX 15/19	2439	1508	931	75	75
140 RSX 15/20	2506	1575	931	75	79
140 RSX 15/21	2633	1642	991	83	82
140 RSX 15/22	2700	1709	991	83	86
140 RSX 15/23	2767	1776	991	83	89
140 RSX 15/24	2834	1843	991	83	93
140 RSX 15/25	2901	1910	991	83	97
140 RSX 15/26	3048	1977	1071	92	100
140 RSX 15/27	3115	2044	1071	92	104
140 RSX 15/28	3182	2111	1071	92	107
140 RSX 15/29	3249	2178	1071	92	111
140 RSX 15/30	3316	2245	1071	92	115
140 RSX 15/31	3493	2312	1181	100	118
140 RSX 15/32	3560	2379	1181	100	122
140 RSX 15/33	3627	2446	1181	100	125
140 RSX 15/34	3694	2513	1181	100	129
140 RSX 15/35	3761	2580	1181	100	133

n% = Rendimento della pompa
 n% = Rendement de la pompe
 n% = Pump efficiency
 n% = Rendimiento de la bomba

**Max
71%**

kW/st = Assorbimento per stadio
 kW/st = Absorption par étage
 kW/st = Stage absorption
 kW/st = Potencia absorbida por etapa

**Max
0,74**

Tolleranza alla sabbia 100 g/m³ - Sand tolerance 100 g/m³ - Compatibilità con acqua potabile DM 174 Drinking water compatibility according to DM 174
 Tolleranze secondo UNI ISO 9906 livello 3B - Tolerances according to UNI ISO 9906 grade 3B

acciaio inox microfuso - elevato rendimento - casted stainless steel - high efficiency



6"

140 RSX15

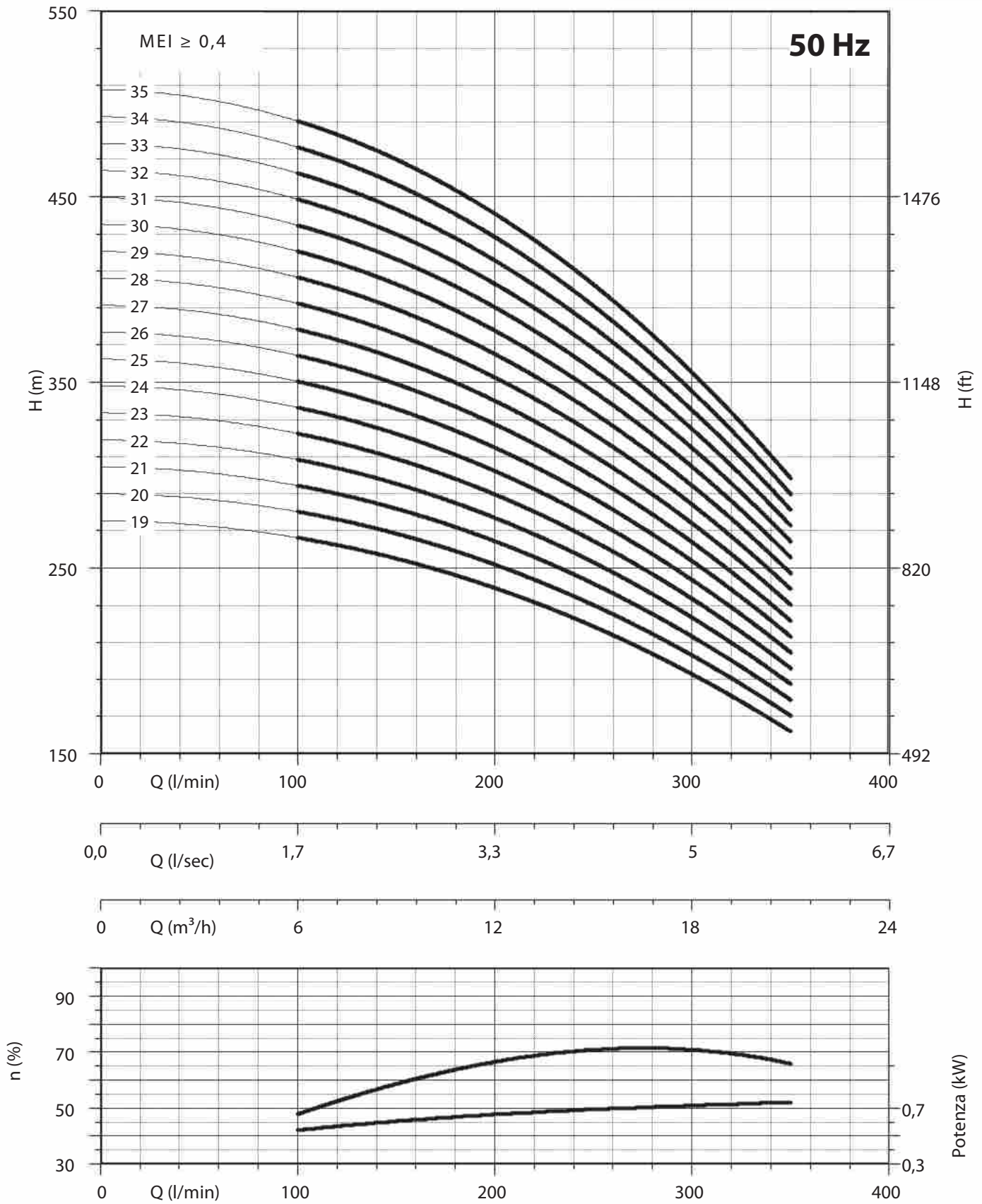

NPSH (m)	25%	50%	75%	100%
140 RSX 15	3	3	4	6

acciaio inox microfuso - elevato rendimento - casted stainless steel - high efficiency

6"

140 RSX18

PANELLI®

CARATTERISTICHE IDRAULICHE - HYDRAULIC PERFORMANCES

Q= Portata - Capacity - Debit **50 Hz n= 2900 min**

Tipo Type	Power		l/min	0	150	200	250	300	350	400	450	
	kW	HP		l/sec	0	2,50	3,33	4,17	5	5,83	6,67	7,5
				m ³ /h	0	9	12	15	18	21	24	27
140 RSX 18/01	1,1	1,5	H(m)	16	14	14	13	12	11	9	7	
140 RSX 18/02	2,2	3		31	28	28	26	25	22	19	15	
140 RSX 18/03	3	4		47	42	41	40	37	33	28	22	
140 RSX 18/04	4	5,5		62	56	55	53	49	44	37	29	
140 RSX 18/05	5,5	7,5		78	71	69	66	62	55	47	37	
140 RSX 18/06	5,5	7,5		93	85	83	79	74	66	56	44	
140 RSX 18/07	7,5	10		109	99	97	92	86	77	65	51	
140 RSX 18/08	7,5	10		124	113	110	106	98	88	74	58	
140 RSX 18/09	9,2	12,5		140	127	124	119	111	99	84	66	
140 RSX 18/10	9,2	12,5		155	141	138	132	123	110	93	73	
140 RSX 18/11	11	15		171	155	152	145	135	121	102	80	
140 RSX 18/12	11	15		186	169	166	158	148	132	112	88	
140 RSX 18/13	13	17,5		202	183	179	172	160	143	121	95	
140 RSX 18/14	13	17,5		217	197	193	185	172	154	130	102	
140 RSX 18/15	15	20		233	212	207	198	185	165	140	110	
140 RSX 18/16	15	20		248	226	221	211	197	176	149	117	
140 RSX 18/17	15	20		264	240	235	224	209	187	158	124	

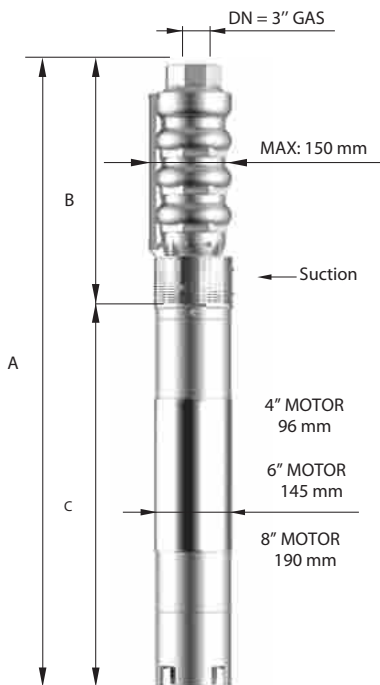

DIMENSIONI D'INGOMBRO E PESI - OVERALL DIMENSIONS AND WEIGHTS

Type	A mm Tri V 400	B mm	C mm Tri	M Kg Tri	P Kg
140 RSX 18/01	664	302	362	12	10
140 RSX 18/02	821	369	452	15	14
140 RSX 18/03	993	436	557	19	17
140 RSX 18/04	1100	503	597	22	21
140 RSX 18/05	1268	570	698	27	25
140 RSX 18/06	1335	637	698	27	28
140 RSX 18/07	1405	704	701	55	32
140 RSX 18/08	1472	771	701	55	35
140 RSX 18/09	1589	838	751	60	39
140 RSX 18/10	1656	905	751	60	43
140 RSX 18/11	1783	972	811	65	46
140 RSX 18/12	1850	1039	811	65	50
140 RSX 18/13	1947	1106	841	70	53
140 RSX 18/14	2014	1173	841	70	57
140 RSX 18/15	2171	1240	931	75	61
140 RSX 18/16	2238	1307	931	75	64
140 RSX 18/17	2305	1374	931	75	68

n% = Rendimento della pompa
 n% = Rendement de la pompe
 n% = Pump efficiency
 n% = Rendimiento de la bomba

**Max
73%**

kW/st = Assorbimento per stadio
 kW/st = Absorption par étage
 kW/st = Stage absorption
 kW/st = Potencia absorbida por etapa

**Max
0,91**

Tolleranza alla sabbia 100 g/m³ - Sand tolerance 100 g/m³ - Compatibilità con acqua potabile DM 174 Drinking water compatibility according to DM 174
 Tolleranze secondo UNI ISO 9906 livello 3B - Tolerances according to UNI ISO 9906 grade 3B

acciaio inox microfuso - elevato rendimento - casted stainless steel - high efficiency



6"

140 RSX18

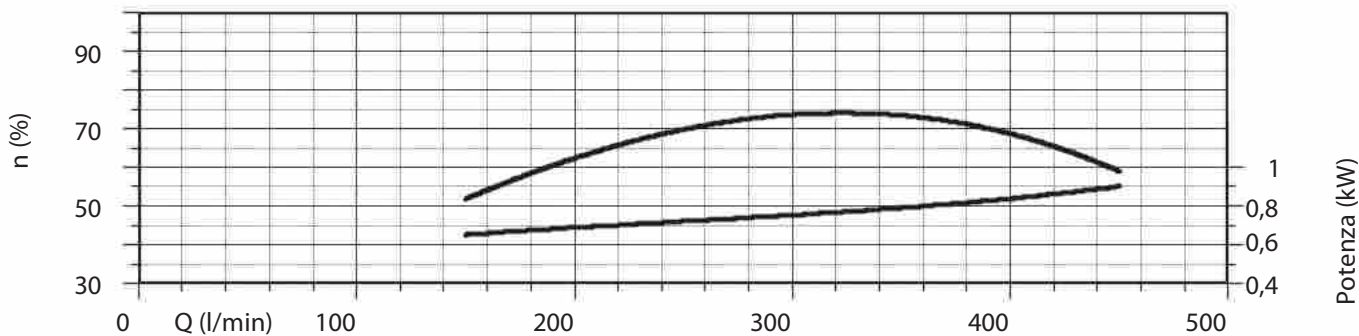
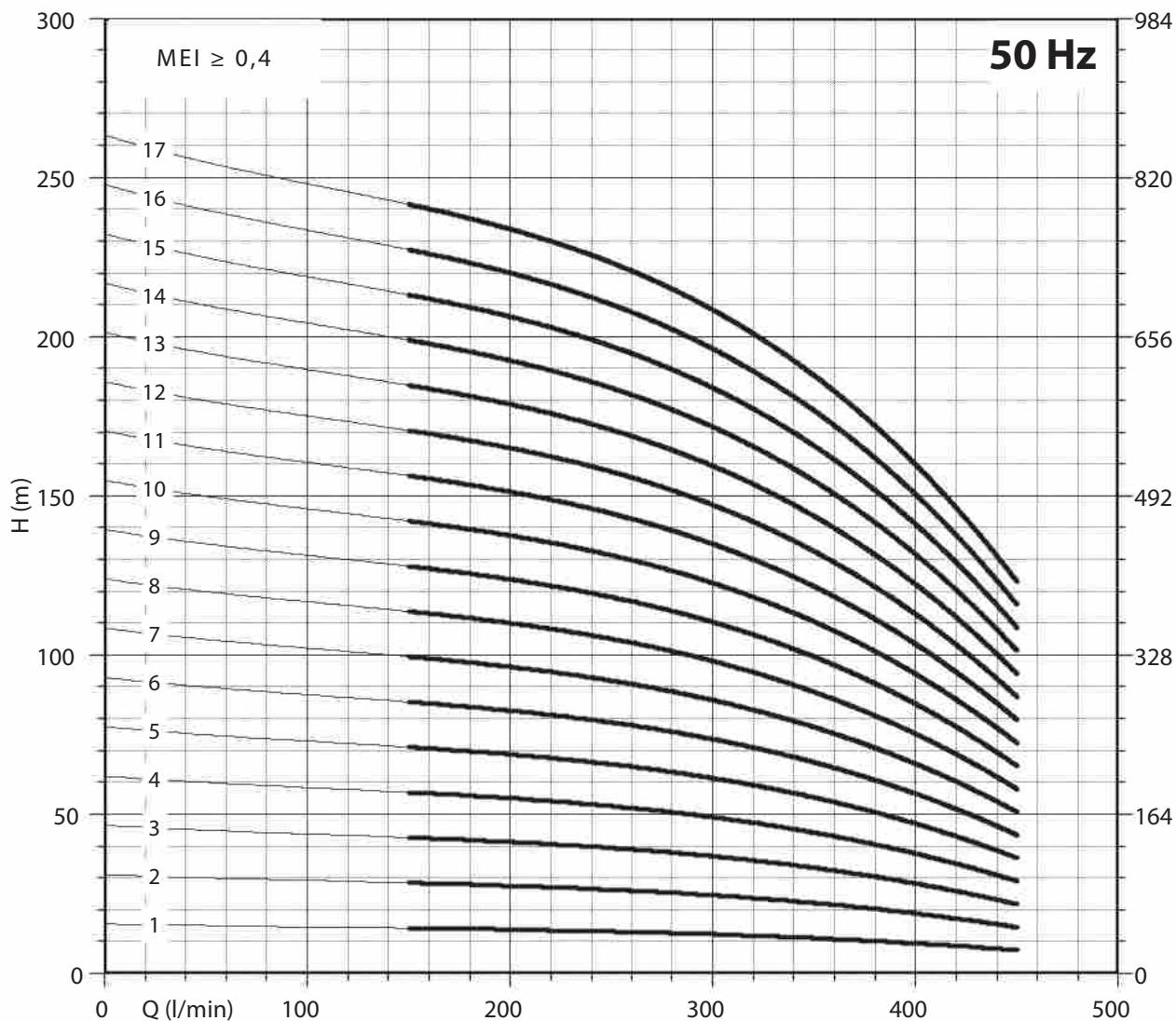

NPSH (m)	25%	50%	75%	100%
140 RSX 18	3	3	4	6

acciaio inox microfuso - elevato rendimento - casted stainless steel - high efficiency

6"

140 RSX18

PANELLI®

CARATTERISTICHE IDRAULICHE - HYDRAULIC PERFORMANCES

Q= Portata - Capacity - Debit **50 Hz n= 2900 min**

Tipo Type	Power		H(m)	0	150	200	250	300	350	400	450			
	kW	HP		l/min	l/sec	m ³ /h	0	2,50	3,33	4,17	5	5,83	6,67	7,50
				0	9	12	15	18	21	24	27			
140 RSX 18/18	18,5	25	280	254	249	237	221	198	167	131				
140 RSX 18/19	18,5	25	295	268	263	250	234	209	177	139				
140 RSX 18/20	18,5	25	311	282	276	264	246	220	186	146				
140 RSX 18/21	18,5	25	326	296	290	277	258	231	195	153				
140 RSX 18/22	22	30	342	311	304	290	270	242	204	160				
140 RSX 18/23	22	30	357	325	318	303	283	253	214	168				
140 RSX 18/24	22	30	373	339	332	316	295	264	223	175				
140 RSX 18/25	22	30	388	353	346	329	307	275	232	182				
140 RSX 18/26	26	35	404	367	359	343	320	286	242	190				
140 RSX 18/27	26	35	419	381	373	356	332	297	251	197				
140 RSX 18/28	26	35	435	395	387	369	344	308	260	204				
140 RSX 18/29	26	35	450	409	401	382	357	319	270	212				
140 RSX 18/30	30	40	466	424	415	395	369	330	279	219				
140 RSX 18/31	30	40	481	438	429	408	381	341	288	226				
140 RSX 18/32	30	40	497	452	442	422	393	352	297	233				
140 RSX 18/33	30	40	512	466	456	435	406	363	307	241				

DIMENSIONI D'INGOMBRO E PESI - OVERALL DIMENSIONS AND WEIGHTS

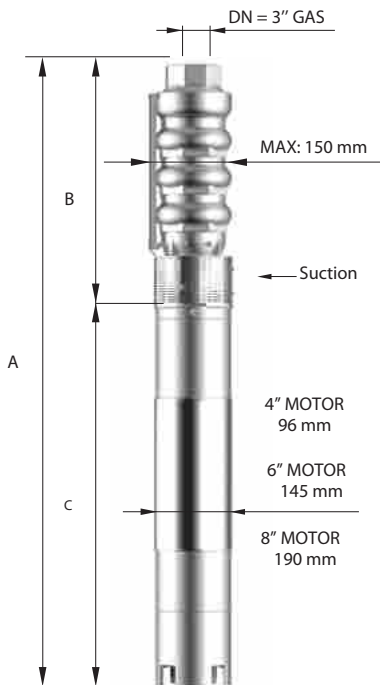

Type	A mm Tri V 400	B mm	C mm Tri	M Kg Tri	P Kg
140 RSX 18/18	2432	1441	991	83	71
140 RSX 18/19	2499	1508	991	83	75
140 RSX 18/20	2566	1575	991	83	79
140 RSX 18/21	2633	1642	991	83	82
140 RSX 18/22	2780	1709	1071	92	86
140 RSX 18/23	2847	1776	1071	92	89
140 RSX 18/24	2914	1843	1071	92	93
140 RSX 18/25	2981	1910	1071	92	97
140 RSX 18/26	3158	1977	1181	100	100
140 RSX 18/27	3225	2044	1181	100	104
140 RSX 18/28	3292	2111	1181	100	107
140 RSX 18/29	3359	2178	1181	100	111
140 RSX 18/30	3496	2245	1251	108	115
140 RSX 18/31	3563	2312	1251	108	118
140 RSX 18/32	3630	2379	1251	108	122
140 RSX 18/33	3697	2446	1251	108	125

n% = Rendimento della pompa
 n% = Rendement de la pompe
 n% = Pump efficiency
 n% = Rendimiento de la bomba

**Max
73%**

kW/st = Assorbimento per stadio
 kW/st = Absorption par étage
 kW/st = Stage absorption
 kW/st = Potencia absorbida por etapa

**Max
0,91**

Tolleranza alla sabbia 100 g/m³ - Sand tolerance 100 g/m³ - Compatibilità con acqua potabile DM 174 Drinking water compatibility according to DM 174
 Tollerances secondo UNI ISO 9906 livello 3B - Tolerances according to UNI ISO 9906 grade 3B

acciaio inox microfuso - elevato rendimento - casted stainless steel - high efficiency



6"

140 RSX18

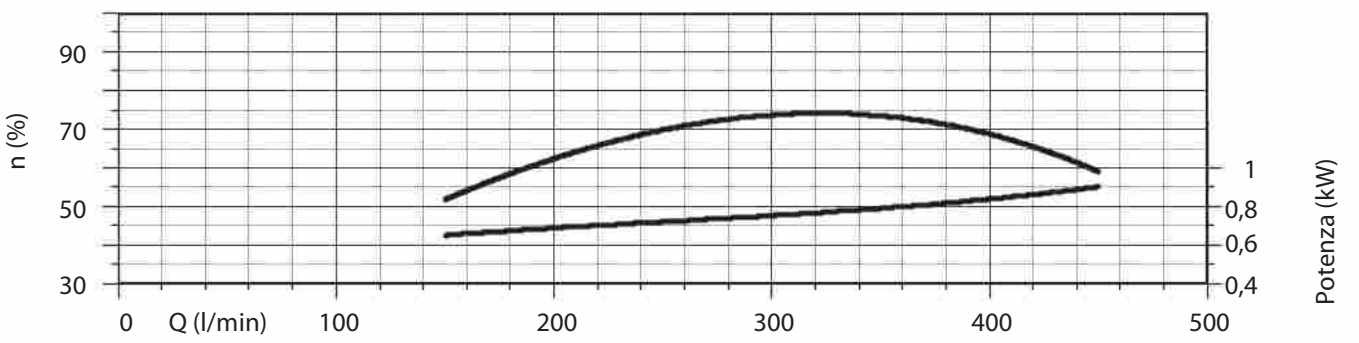
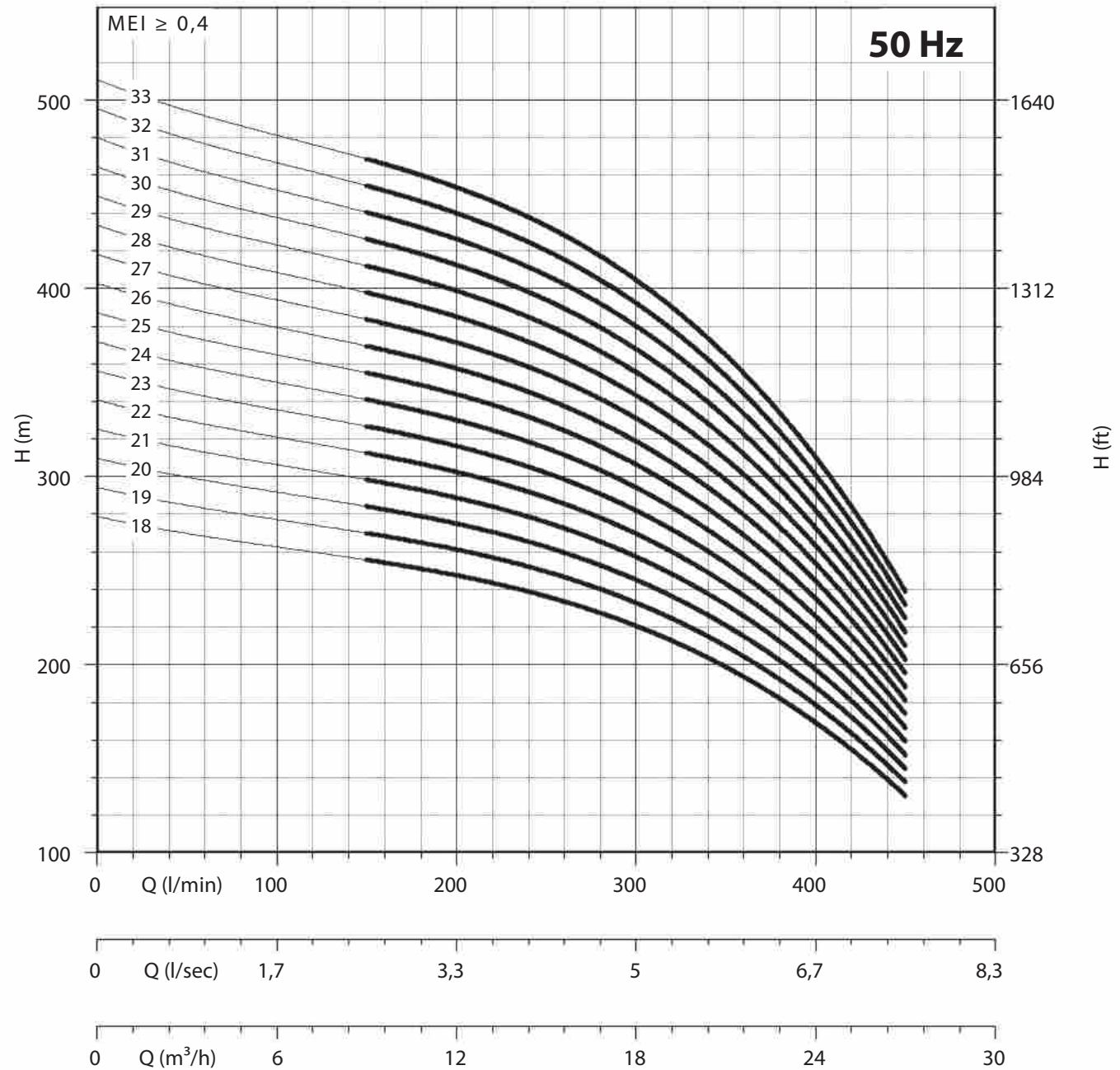

NPSH (m)	25%	50%	75%	100%
140 RSX 18	3	3	4	6

acciaio inox microfuso - elevato rendimento - casted stainless steel - high efficiency

6"

140 RSX24

PANELLI®

CARATTERISTICHE IDRAULICHE - HYDRAULIC PERFORMANCES

Q= Portata - Capacity - Debit

50 Hz n= 2900 min

Tipo Type	Power		H(m)	0	200	250	300	350	400	450	500	550
	kW	HP		l/min	l/sec	l/min	l/min	l/min	l/min	l/min	l/min	l/min
				m ³ /h	m ³ /h	m ³ /h	m ³ /h	m ³ /h	m ³ /h	m ³ /h	m ³ /h	m ³ /h
140 RSX 24/01	1,1	1,5	15	13	13	13	12	12	11	10	8	
140 RSX 24/02	2,2	3	30	27	26	25	25	23	21	19	17	
140 RSX 24/03	4	5,5	45	40	39	38	37	35	32	29	25	
140 RSX 24/04	5,5	7,5	60	54	52	51	49	46	43	38	34	
140 RSX 24/05	5,5	7,5	75	67	66	63	61	58	54	48	42	
140 RSX 24/06	7,5	10	90	80	79	76	74	70	64	57	50	
140 RSX 24/07	9,2	12,5	105	94	92	89	86	81	75	67	59	
140 RSX 24/08	9,2	12,5	120	107	105	101	98	93	86	76	67	
140 RSX 24/09	11	15	135	121	118	114	111	105	96	86	76	
140 RSX 24/10	11	15	150	134	131	127	123	116	107	95	84	
140 RSX 24/11	13	17,5	165	147	144	139	135	128	118	105	92	
140 RSX 24/12	15	20	180	161	157	152	147	139	129	114	101	
140 RSX 24/13	15	20	195	174	170	165	160	151	139	124	109	
140 RSX 24/14	18,5	25	210	187	184	177	172	163	150	133	117	
140 RSX 24/15	18,5	25	225	201	197	190	184	174	161	143	126	
140 RSX 24/16	18,5	25	240	214	210	203	196	186	172	152	134	
140 RSX 24/17	22	30	255	228	223	215	209	197	182	162	143	
140 RSX 24/18	22	30	270	241	236	228	221	209	193	171	151	

DIMENSIONI D'INGOMBRO E PESI - OVERALL DIMENSIONS AND WEIGHTS

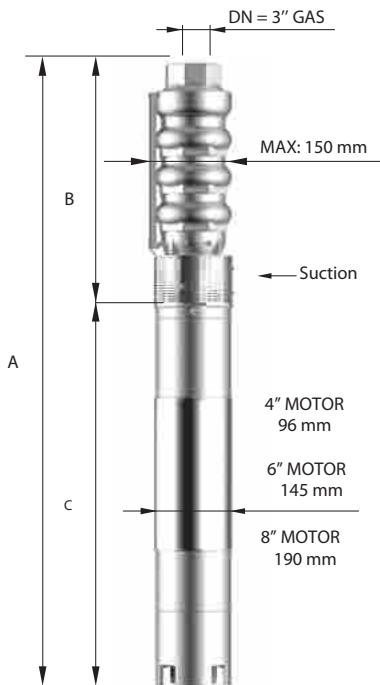

Type	A mm Tri V 400	B mm	C mm Tri	M Kg Tri	P Kg
140 RSX 24/01	664	302	362	12	10
140 RSX 24/02	821	369	452	15	14
140 RSX 24/03	1033	436	597	22	18
140 RSX 24/04	1201	503	698	27	21
140 RSX 24/05	1268	570	698	27	25
140 RSX 24/06	1338	637	701	55	29
140 RSX 24/07	1455	704	751	60	32
140 RSX 24/08	1522	771	751	60	36
140 RSX 24/09	1649	838	811	65	40
140 RSX 24/10	1716	905	811	65	44
140 RSX 24/11	1813	972	841	70	47
140 RSX 24/12	1970	1039	931	75	51
140 RSX 24/13	2037	1106	931	75	55
140 RSX 24/14	2164	1173	991	83	58
140 RSX 24/15	2231	1240	991	83	62
140 RSX 24/16	2298	1307	991	83	66
140 RSX 24/17	2445	1374	1071	92	69
140 RSX 24/18	2512	1441	1071	92	73

n% = Rendimento della pompa
 n% = Rendement de la pompe
 n% = Pump efficiency
 n% = Rendimiento de la bomba

**Max
77%**

kW/st = Assorbimento per stadio
 kW/st = Absorption par étage
 kW/st = Stage absorption
 kW/st = Potencia absorbida por etapa

**Max
1,14**

Tolleranza alla sabbia 100 g/m³ - Sand tolerance 100 g/m³ - Compatibilità con acqua potabile DM 174 Drinking water compatibility according to DM 174
 Tolleranze secondo UNI ISO 9906 livello 3B - Tolerances according to UNI ISO 9906 grade 3B

acciaio inox microfuso - elevato rendimento - casted stainless steel - high efficiency



6"

140 RSX24

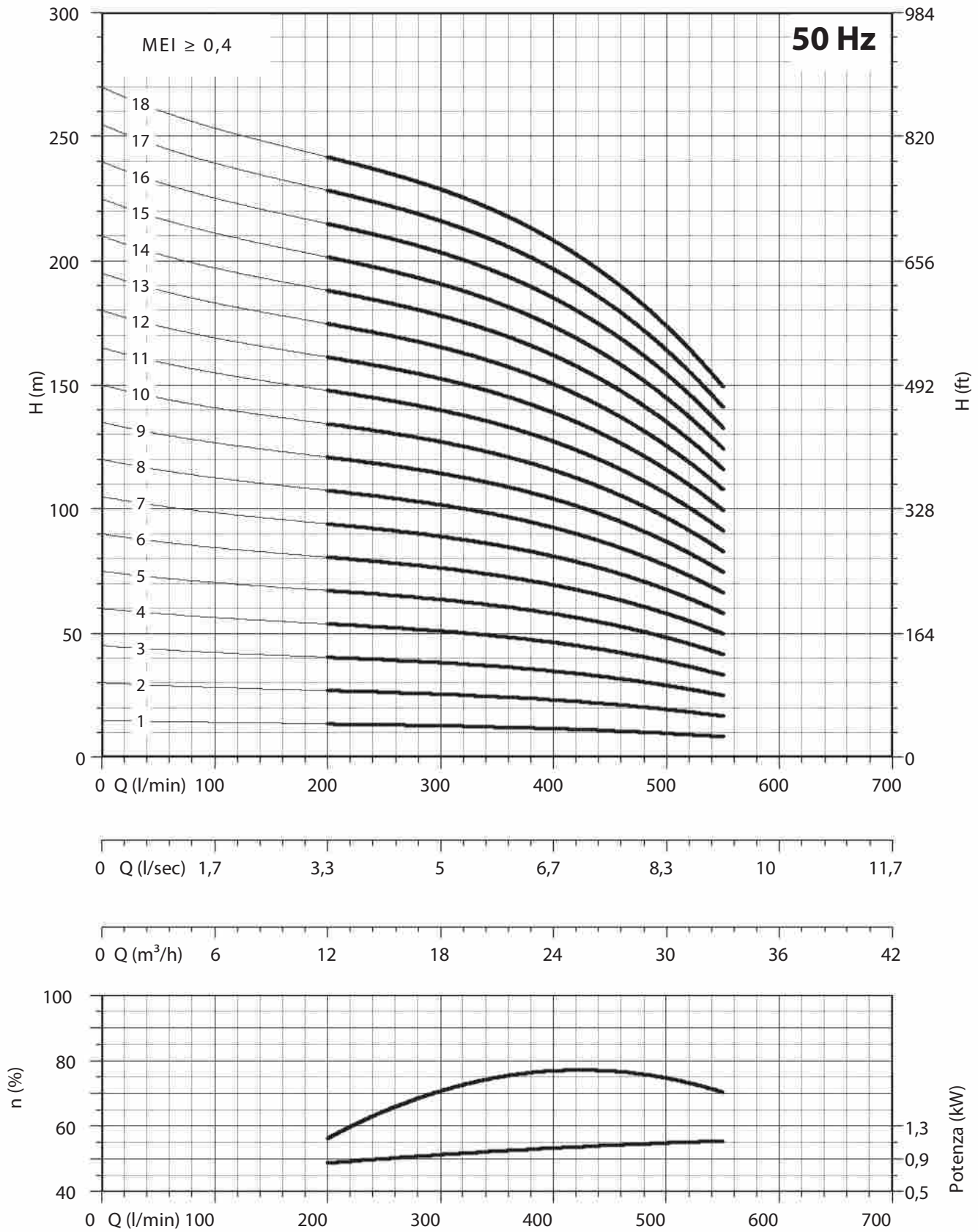

NPSH (m)	25%	50%	75%	100%
140 RSX 24	3	3	4,5	6,6

acciaio inox microfuso - elevato rendimento - casted stainless steel - high efficiency

6"

140 RSX24

PANELLI®

CARATTERISTICHE IDRAULICHE - HYDRAULIC PERFORMANCES

Q= Portata - Capacity - Debit **50 Hz n= 2900 min**

Tipo Type	Power		l/min	0	200	250	300	350	400	450	500	550	
	kW	HP		l/sec	0	3,33	4,17	5	5,83	6,67	7,5	8,33	9,17
				m ³ /h	0	12	15	18	21	24	27	30	33
140 RSX 24/19	22	30	H(m)	285	254	249	241	233	221	204	181	159	
140 RSX 24/20	26	35		300	268	262	253	246	232	214	190	168	
140 RSX 24/21	26	35		315	281	275	266	258	244	225	200	176	
140 RSX 24/22	26	35		330	295	288	279	270	255	236	209	185	
140 RSX 24/23	26	35		345	308	302	291	282	267	247	219	193	
140 RSX 24/24	30	40		360	321	315	304	295	279	257	228	201	
140 RSX 24/25	30	40		375	335	328	317	307	290	268	238	210	
140 RSX 24/26	30	40		390	348	341	329	319	302	279	247	218	
140 RSX 24/27	30	40		405	362	354	342	332	314	289	257	227	
140 RSX 24/28	37	50		420	375	367	355	344	325	300	266	235	
140 RSX 24/29	37	50		435	388	380	367	356	337	311	276	243	
140 RSX 24/30	37	50		450	402	393	380	368	348	322	285	252	
140 RSX 24/31	37	50		465	415	406	393	381	360	332	295	260	
140 RSX 24/32	37	50		480	428	420	405	393	372	343	304	268	
140 RSX 24/33	37	50		495	442	433	418	405	383	354	314	277	

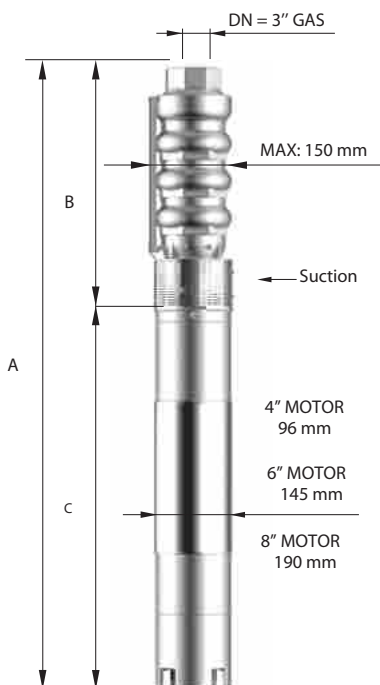

DIMENSIONI D'INGOMBRO E PESI - OVERALL DIMENSIONS AND WEIGHTS

Type	A mm Tri V 400	B mm	C mm Tri	M Kg Tri	P Kg
140 RSX 24/19	2579	1508	1071	92	77
140 RSX 24/20	2756	1575	1181	100	81
140 RSX 24/21	2823	1642	1181	100	84
140 RSX 24/22	2890	1709	1181	100	88
140 RSX 24/23	2957	1776	1181	100	92
140 RSX 24/24	3094	1843	1251	108	95
140 RSX 24/25	3161	1910	1251	108	99
140 RSX 24/26	3228	1977	1251	108	103
140 RSX 24/27	3295	2044	1251	108	106
140 RSX 24/28	3452	2111	1341	118	110
140 RSX 24/29	3519	2178	1341	118	114
140 RSX 24/30	3586	2245	1341	118	118
140 RSX 24/31	3653	2312	1341	118	121
140 RSX 24/32	3720	2379	1341	118	125
140 RSX 24/33	3787	2446	1341	118	129

n% = Rendimento della pompa
 n% = Rendement de la pompe
 n% = Pump efficiency
 n% = Rendimiento de la bomba

Max 77%

kW/st = Assorbimento per stadio
 kW/st = Absorption par étage
 kW/st = Stage absorption
 kW/st = Potencia absorbida por etapa

Max 1,14

Tolleranza alla sabbia 100 g/m³ - Sand tolerance 100 g/m³ - Compatibilità con acqua potabile DM 174 Drinking water compatibility according to DM 174
 Tolleranze secondo UNI ISO 9906 livello 3B - Tolerances according to UNI ISO 9906 grade 3B

acciaio inox microfuso - elevato rendimento - casted stainless steel - high efficiency



6"

140 RSX24

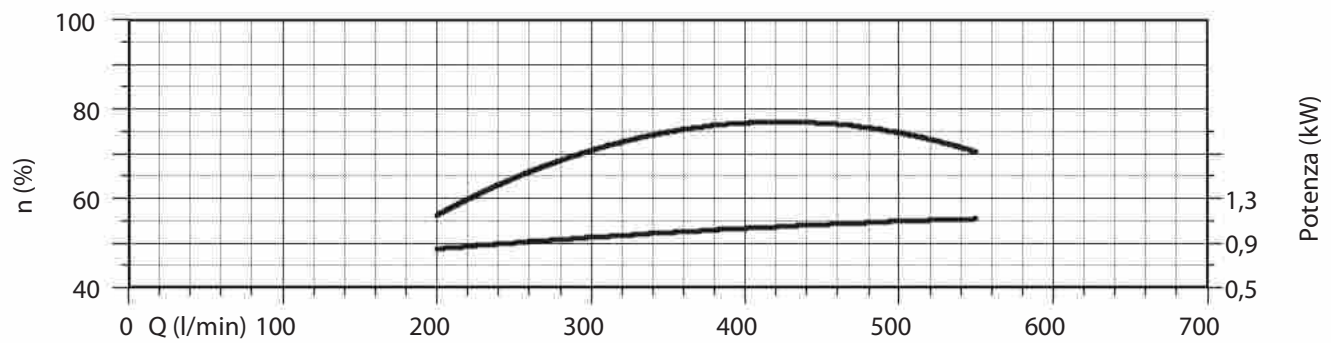
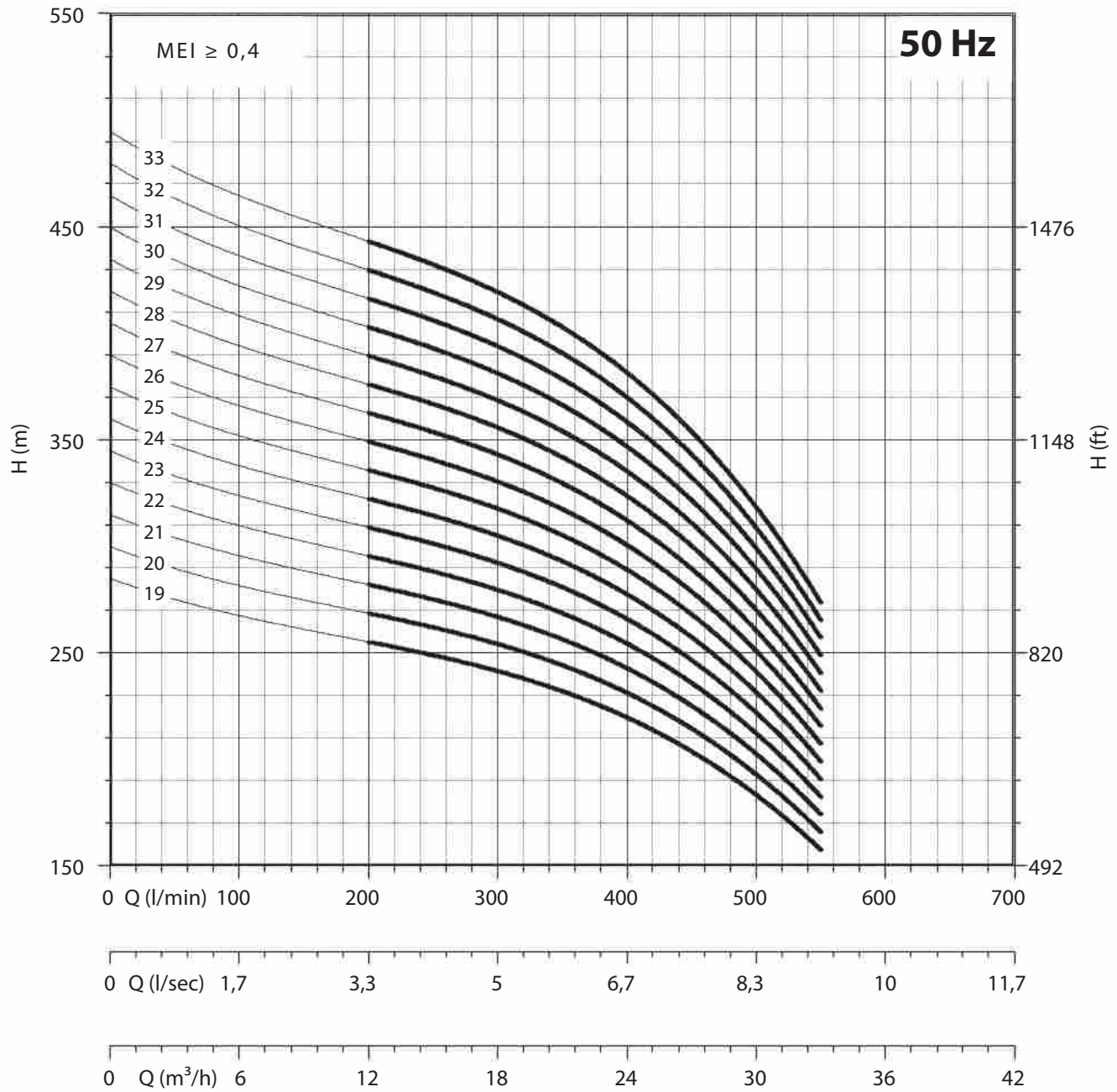

NPSH (m)	25%	50%	75%	100%
140 RSX 24	3	3	4,5	6,6

acciaio inox microfuso - elevato rendimento - casted stainless steel - high efficiency

6"

140 RSX30

PANELLI®

CARATTERISTICHE IDRAULICHE - HYDRAULIC PERFORMANCES

Q= Portata - Capacity - Debit

50 Hz n= 2900 min

Tipo Type	Power		l/min	0	200	300	400	500	600	700	
	kW	HP		l/sec	0	3,33	5	6,67	8,33	10	700
				m ³ /h	0	12	18	24	30	36	42
140 RSX 30/01	1,5	2	H(m)	15	14	14	13	11	9	7	
140 RSX 30/02	3	4		30	28	27	25	23	19	15	
140 RSX 30/03	4	5,5		45	42	41	38	34	28	22	
140 RSX 30/04	5,5	7,5		60	56	54	51	45	38	29	
140 RSX 30/05	7,5	10		75	71	68	63	56	47	36	
140 RSX 30/06	9,2	12,5		90	85	81	76	68	56	44	
140 RSX 30/07	9,2	12,5		105	99	95	89	79	66	51	
140 RSX 30/08	11	15		120	113	108	101	90	75	58	
140 RSX 30/09	13	17,5		135	127	122	114	102	85	66	
140 RSX 30/10	13	17,5		150	141	136	127	113	94	73	
140 RSX 30/11	15	20		165	155	149	139	124	103	80	
140 RSX 30/12	18,5	25		180	169	163	152	135	113	87	
140 RSX 30/13	18,5	25		195	183	176	165	147	122	95	
140 RSX 30/14	18,5	25		210	198	190	177	158	131	102	
140 RSX 30/15	22	30		225	212	203	190	169	141	109	
140 RSX 30/16	22	30		240	226	217	203	180	150	116	
140 RSX 30/17	22	30		255	240	230	215	192	160	124	
140 RSX 30/18	26	35		270	254	244	228	203	169	131	

DIMENSIONI D'INGOMBRO E PESI - OVERALL DIMENSIONS AND WEIGHTS

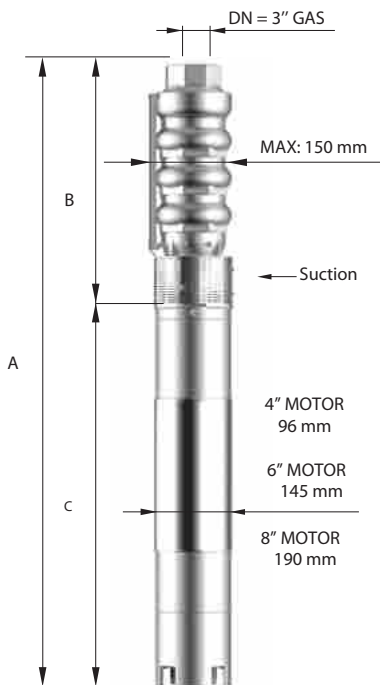

Type	A mm Tri V 400	B mm	C mm Tri	M Kg Tri	P Kg
140 RSX 30/01	694	302	392	13	10
140 RSX 30/02	926	369	557	19	14
140 RSX 30/03	1033	436	597	22	18
140 RSX 30/04	1201	503	698	27	21
140 RSX 30/05	1271	570	701	55	25
140 RSX 30/06	1388	637	751	60	29
140 RSX 30/07	1455	704	751	60	32
140 RSX 30/08	1582	771	811	65	36
140 RSX 30/09	1679	838	841	70	40
140 RSX 30/10	1746	905	841	70	44
140 RSX 30/11	1903	972	931	75	47
140 RSX 30/12	2030	1039	991	83	51
140 RSX 30/13	2097	1106	991	83	55
140 RSX 30/14	2164	1173	991	83	58
140 RSX 30/15	2311	1240	1071	92	62
140 RSX 30/16	2378	1307	1071	92	66
140 RSX 30/17	2445	1374	1071	92	69
140 RSX 30/18	2622	1441	1181	100	73

n% = Rendimento della pompa
 n% = Rendement de la pompe
 n% = Pump efficiency
 n% = Rendimiento de la bomba

Max 77%

kW/st = Assorbimento per stadio
 kW/st = Absorption par étage
 kW/st = Stage absorption
 kW/st = Potencia absorbida por etapa

Max 1,32

Tolleranza alla sabbia 100 g/m³ - Sand tolerance 100 g/m³ - Compatibilità con acqua potabile DM 174 Drinking water compatibility according to DM 174
 Tolleranze secondo UNI ISO 9906 livello 3B - Tolerances according to UNI ISO 9906 grade 3B

acciaio inox microfuso - elevato rendimento - casted stainless steel - high efficiency



6"

140 RSX30

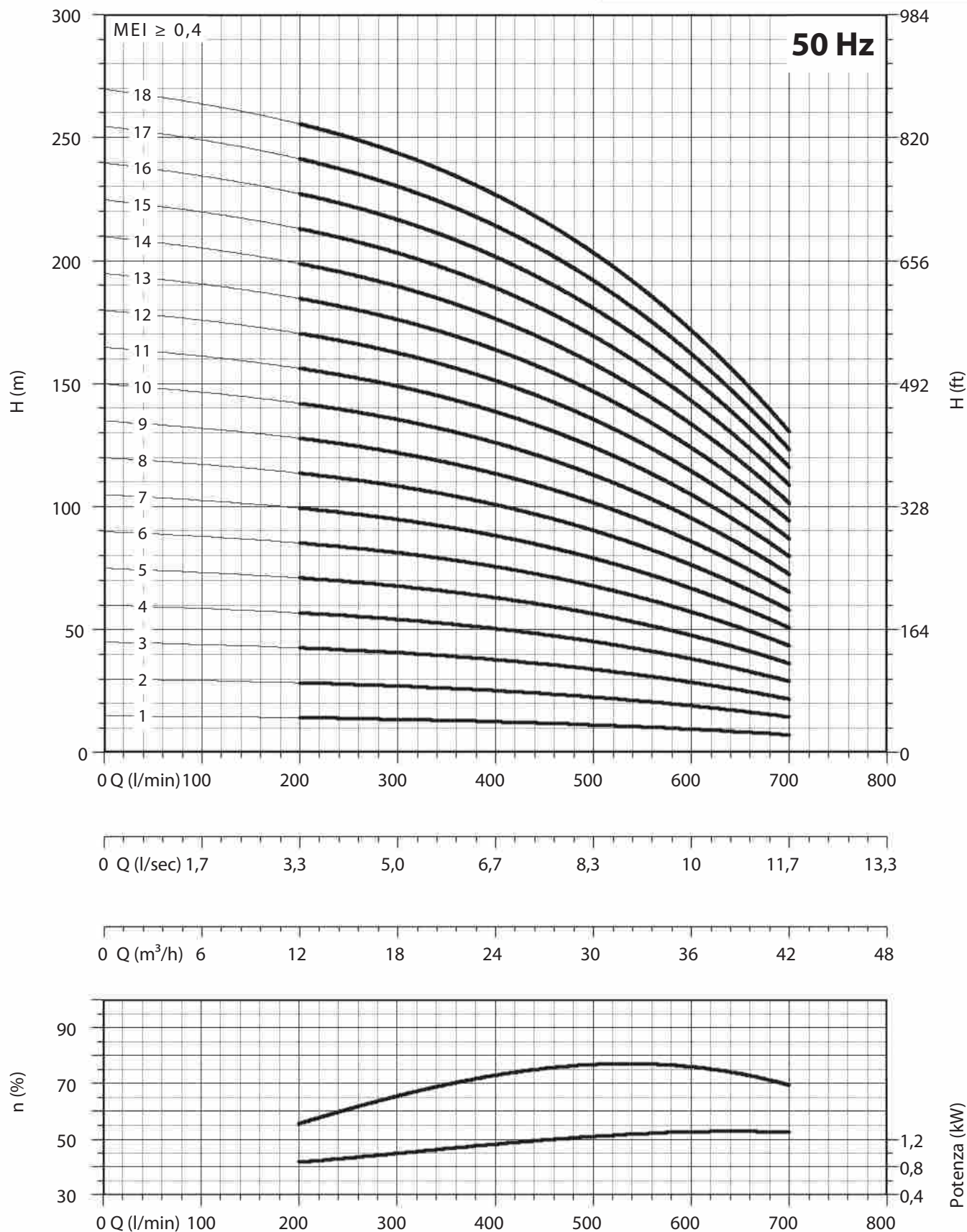

NPSH (m)	25%	50%	75%	100%
140 RSX 30	3,4	3,4	3,9	7,5

acciaio inox microfuso - elevato rendimento - casted stainless steel - high efficiency

6"

140 RSX30

PANELLI®

CARATTERISTICHE IDRAULICHE - HYDRAULIC PERFORMANCES

Q= Portata - Capacity - Debit **50 Hz n= 2900 min**

Tipo Type	Power		l/min	0	200	300	400	500	600	700	
	kW	HP		l/sec	0	3,33	5	6,67	8,33	10	11,67
				m³/h	0	12	18	24	30	36	42
140 RSX 30/19	26	35	H(m)	285	268	258	241	214	178	138	
140 RSX 30/20	26	35		300	282	271	253	226	188	146	
140 RSX 30/21	30	40		315	296	285	266	237	197	153	
140 RSX 30/22	30	40		330	310	298	279	248	207	160	
140 RSX 30/23	30	40		345	325	312	291	259	216	167	
140 RSX 30/24	37	50		360	339	325	304	271	225	175	
140 RSX 30/25	37	50		375	353	339	317	282	235	182	
140 RSX 30/26	37	50		390	367	352	329	293	244	189	
140 RSX 30/27	37	50		405	381	366	342	305	254	197	
140 RSX 30/28	37	50		420	395	380	355	316	263	204	
140 RSX 30/29	37	50		435	409	393	367	327	272	211	
140 RSX 30/30	44	60		450	423	407	380	338	282	218	
140 RSX 30/31	44	60		465	437	420	393	350	291	226	
140 RSX 30/32	44	60		480	452	434	405	361	300	233	
140 RSX 30/33	44	60		495	466	447	418	372	310	240	
140 RSX 30/34	44	60		510	480	461	431	383	319	247	

DIMENSIONI D'INGOMBRO E PESI - OVERALL DIMENSIONS AND WEIGHTS

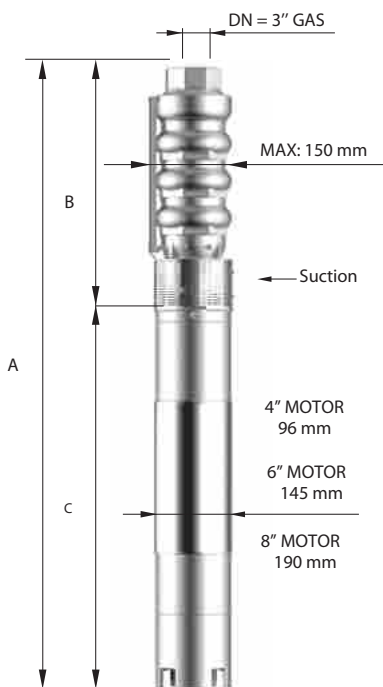

Type	A mm Tri V 400	B mm	C mm Tri	M Kg Tri	P Kg
140 RSX 30/19	2689	1508	1181	100	77
140 RSX 30/20	2756	1575	1181	100	81
140 RSX 30/21	2893	1642	1251	108	84
140 RSX 30/22	2960	1709	1251	108	88
140 RSX 30/23	3027	1776	1251	108	92
140 RSX 30/24	3184	1843	1341	118	95
140 RSX 30/25	3251	1910	1341	118	99
140 RSX 30/26	3318	1977	1341	118	103
140 RSX 30/27	3385	2044	1341	118	106
140 RSX 30/28	3452	2111	1341	118	110
140 RSX 30/29	3519	2178	1341	118	114
140 RSX 30/30	3368	2245	1123	178	118
140 RSX 30/31	3435	2312	1123	178	121
140 RSX 30/32	3502	2379	1123	178	125
140 RSX 30/33	3569	2446	1123	178	129
140 RSX 30/34	3636	2513	1123	178	132

n% = Rendimento della pompa
 n% = Rendement de la pompe
 n% = Pump efficiency
 n% = Rendimiento de la bomba

**Max
77%**

kW/st = Assorbimento per stadio
 kW/st = Absorption par étage
 kW/st = Stage absorption
 kW/st = Potencia absorbida por etapa

**Max
1,32**

Tolleranza alla sabbia 100 g/m³ - Sand tolerance 100 g/m³ - Compatibilità con acqua potabile DM 174 Drinking water compatibility according to DM 174
 Tolleranza secondo UNI ISO 9906 livello 3B - Tolerances according to UNI ISO 9906 grade 3B

acciaio inox microfuso - elevato rendimento - casted stainless steel - high efficiency



6"

140 RSX30

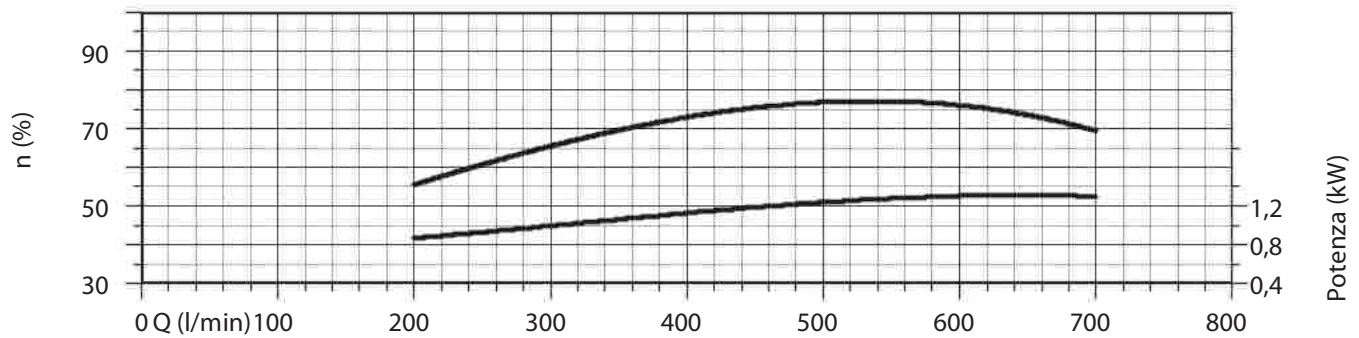
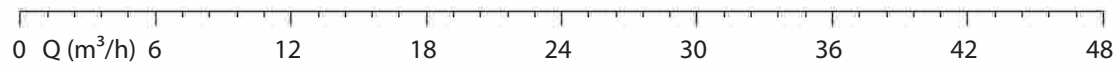
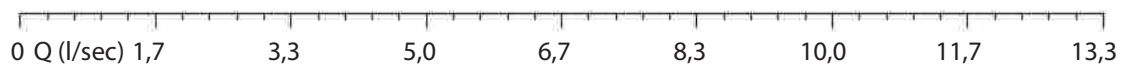
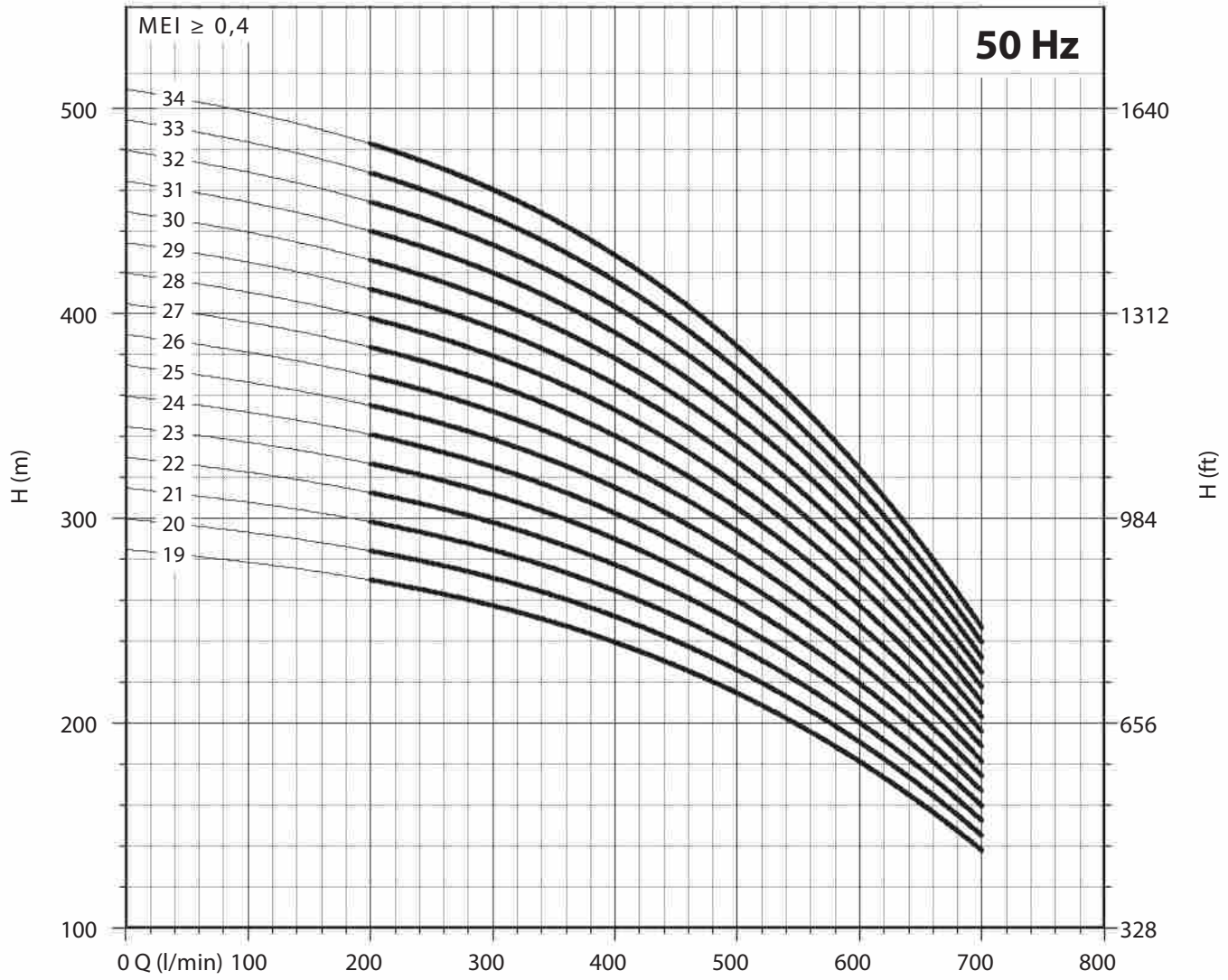

NPSH (m)	25%	50%	75%	100%
140 RSX 30	3,4	3,4	3,9	7,5

acciaio inox microfuso - elevato rendimento - casted stainless steel - high efficiency

8"

180 RSX32

PANELLI®

CARATTERISTICHE IDRAULICHE - HYDRAULIC PERFORMANCES

Q= Portata - Capacity - Debit

50 Hz n= 2900 min

Tipo Type	Power		H(m)	0	200	300	400	500	600	700	
	kW	HP		l/min	0	3,33	5	6,67	8,33	10	11,67
				l/sec	0	12	18	24	30	36	42
				m ³ /h	0	23	21	20	20	18	17
180 RSX 32/01	3	4	23	21	20	20	18	17	14		
180 RSX 32/02	5,5	7,5	46	42	41	39	37	33	28		
180 RSX 32/03	7,5	10	69	64	61	59	55	50	41		
180 RSX 32/04	11	15	92	85	82	78	73	66	55		
180 RSX 32/05	13	17,5	115	106	102	98	91	83	69		
180 RSX 32/06	15	20	138	127	123	117	110	99	83		
180 RSX 32/07	18,5	25	161	149	143	137	128	116	97		
180 RSX 32/08	22	30	184	170	163	156	146	132	110		
180 RSX 32/09	22	30	207	191	184	176	165	149	124		
180 RSX 32/10	26	35	230	212	204	195	183	165	138		
180 RSX 32/11	26	35	253	233	225	215	201	182	152		
180 RSX 32/12	30	40	276	255	245	234	219	198	165		
180 RSX 32/13	37	50	299	276	266	254	238	215	179		
180 RSX 32/14	37	50	322	297	286	273	256	231	193		

DIMENSIONI D'INGOMBRO E PESI - OVERALL DIMENSIONS AND WEIGHTS

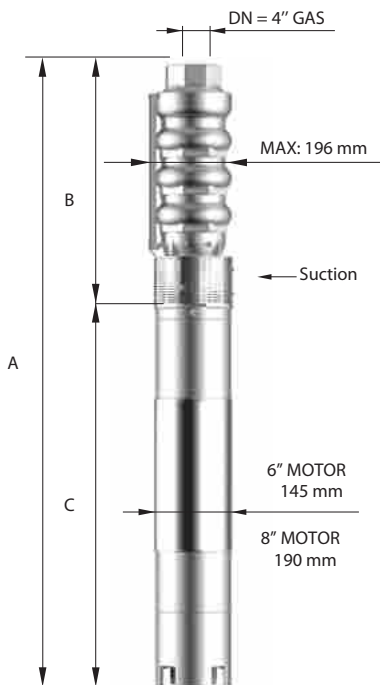

Type	A mm Tri V 400	B mm	C mm Tri	M Kg Tri	P Kg
180 RSX 32/01	947	390	557	19	16
180 RSX 32/02	1168	470	698	27	22
180 RSX 32/03	1251	550	701	55	28
180 RSX 32/04	1441	630	811	65	34
180 RSX 32/05	1551	710	841	70	40
180 RSX 32/06	1721	790	931	75	46
180 RSX 32/07	1861	870	991	83	52
180 RSX 32/08	2021	950	1071	92	58
180 RSX 32/09	2101	1030	1071	92	64
180 RSX 32/10	2291	1110	1181	100	71
180 RSX 32/11	2371	1190	1181	100	77
180 RSX 32/12	2521	1270	1251	108	83
180 RSX 32/13	2691	1350	1341	118	89
180 RSX 32/14	2771	1430	1341	118	95

n% = Rendimento della pompa
 n% = Rendement de la pompe
 n% = Pump efficiency
 n% = Rendimiento de la bomba

**Max
73,5%**

kW/st = Assorbimento per stadio
 kW/st = Absorption par étage
 kW/st = Stage absorption
 kW/st = Potencia absorbida por etapa

**Max
2,4**

Tolleranza alla sabbia 100 g/m³ - Sand tolerance 100 g/m³ - Compatibilità con acqua potabile DM 174 Drinking water compatibility according to DM 174
 Tolleranze secondo UNI ISO 9906 livello 3B - Tolerances according to UNI ISO 9906 grade 3B

acciaio inox microfuso - elevato rendimento - casted stainless steel - high efficiency

PANELLI®

8"

180 RSX32

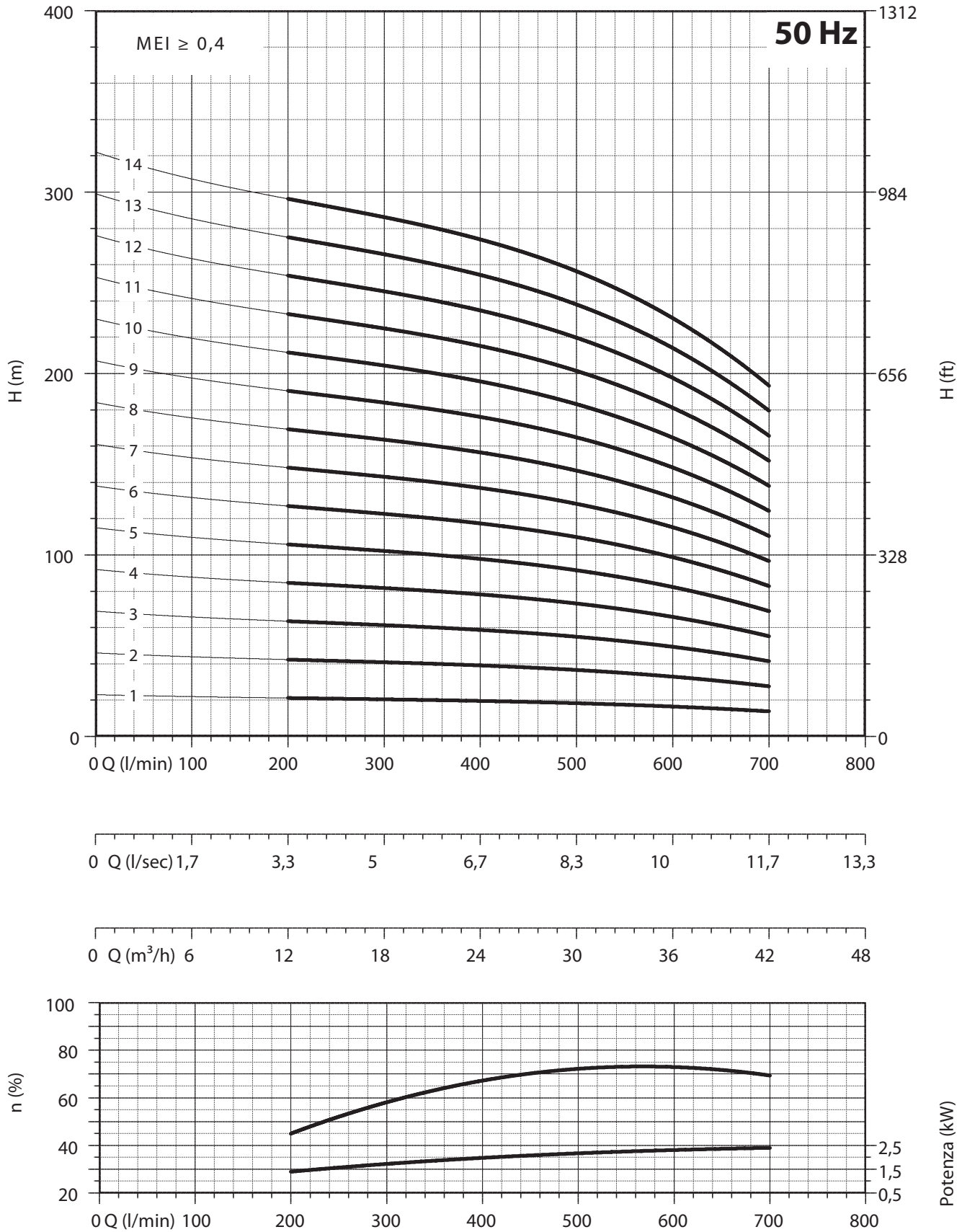

NPSH (m)	25%	50%	75%	100%
180 RSX 32	3,3	3,3	4,5	6,7

acciaio inox microfuso - elevato rendimento - casted stainless steel - high efficiency

8"

180 RSX32

PANELLI®

CARATTERISTICHE IDRAULICHE - HYDRAULIC PERFORMANCES

Q= Portata - Capacity - Debit

50 Hz n= 2900 min

Tipo Type	Power		H(m)	0	200	300	400	500	600	700			
	kW	HP		l/min	l/sec	m ³ /h	0	3,33	5	6,67	8,33	10	11,67
				0	12	18	24	30	36	42			
180 RSX 32/15	37	50		345	318	306	293	274	248	207			
180 RSX 32/16	44	60		368	339	327	312	293	264	221			
180 RSX 32/17	44	60		391	361	347	332	311	281	234			
180 RSX 32/18	44	60		414	382	368	351	329	297	248			
180 RSX 32/19	44	60		437	403	388	371	347	314	262			
180 RSX 32/20	55	75		460	424	409	390	366	330	276			
180 RSX 32/21	55	75		483	446	429	410	384	347	290			
180 RSX 32/22	55	75		506	467	449	429	402	363	303			
180 RSX 32/23	55	75		529	488	470	449	421	380	317			
180 RSX 32/24	66	90		552	509	490	468	439	396	331			
180 RSX 32/25	66	90		575	530	511	488	457	413	345			
180 RSX 32/26	66	90		598	552	531	507	475	429	358			
180 RSX 32/27	66	90		621	573	552	527	494	446	372			

DIMENSIONI D'INGOMBRO E PESI - OVERALL DIMENSIONS AND WEIGHTS

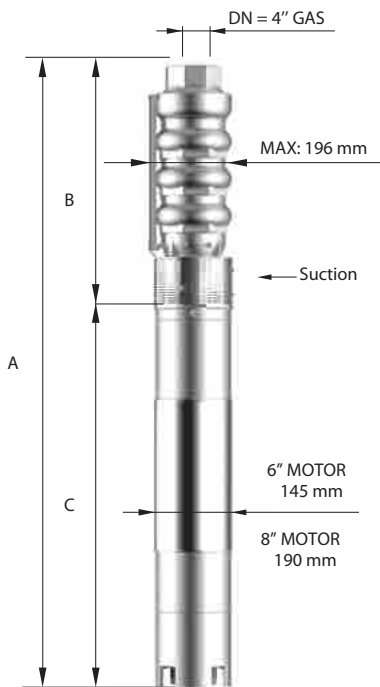

Type	A mm Tri V 400	B mm	C mm Tri	M Kg Tri	P Kg
180 RSX 32/15	2851	1510	1341	118	101
180 RSX 32/16	2713	1590	1123	178	107
180 RSX 32/17	2793	1670	1123	178	113
180 RSX 32/18	2873	1750	1123	178	119
180 RSX 32/19	2953	1830	1123	178	125
180 RSX 32/20	3143	1910	1233	200	132
180 RSX 32/21	3223	1990	1233	200	138
180 RSX 32/22	3303	2070	1233	200	144
180 RSX 32/23	3383	2150	1233	200	150
180 RSX 32/24	3533	2230	1303	214	156
180 RSX 32/25	3613	2310	1303	214	162
180 RSX 32/26	3693	2390	1303	214	168
180 RSX 32/27	3773	2470	1303	214	174

n% = Rendimento della pompa
 n% = Rendement de la pompe
 n% = Pump efficiency
 n% = Rendimiento de la bomba

**Max
73,5%**

kW/st = Assorbimento per stadio
 kW/st = Absorption par étage
 kW/st = Stage absorption
 kW/st = Potencia absorbida por etapa

**Max
2,4**

Tolleranza alla sabbia 100 g/m³ - Sand tolerance 100 g/m³ - Compatibilità con acqua potabile DM 174 Drinking water compatibility according to DM 174
 Tolleranze secondo UNI ISO 9906 livello 3B - Tolerances according to UNI ISO 9906 grade 3B

acciaio inox microfuso - elevato rendimento - casted stainless steel - high efficiency

PANELLI®

8"

180 RSX32

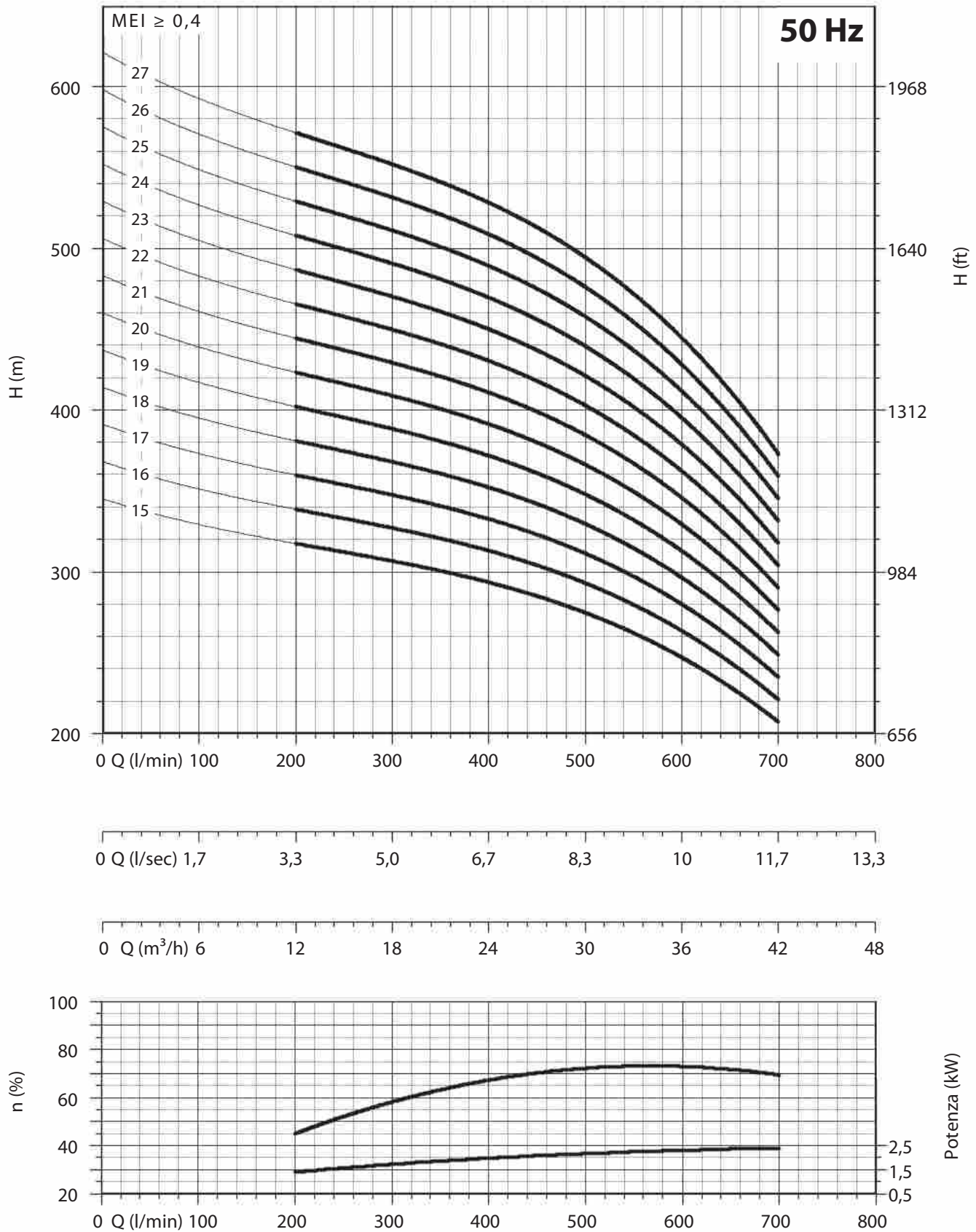

NPSH (m)	25%	50%	75%	100%
180 RSX 32	3	3	4,5	6,7

6" - 8" RSX - 25

acciaio inox microfuso - elevato rendimento - casted stainless steel - high efficiency

8"

180 RSX40

PANELLI®

CARATTERISTICHE IDRAULICHE - HYDRAULIC PERFORMANCES

Q= Portata - Capacity - Debit **50 Hz n= 2900 min**

Tipo Type	Power		H(m)	0	300	400	500	600	700	800	900	
	kW	HP		l/min	l/sec	m ³ /h	l/min	l/sec	m ³ /h	l/min	l/sec	m ³ /h
				0	5	6,67	8,33	10	11,67	13,33	15	
180 RSX 40/01	3	4		0	18	24	30	36	42	48	54	
180 RSX 40/02	5,5	7,5		24	22	21	20	18	16	14	11	
180 RSX 40/03	9,2	12,5		48	43	42	39	36	32	28	21	
180 RSX 40/04	11	15		72	65	62	59	55	49	41	32	
180 RSX 40/05	15	20		96	86	83	78	73	65	55	42	
180 RSX 40/06	18,5	25		120	108	104	98	91	81	69	53	
180 RSX 40/07	22	30		144	130	125	118	109	97	83	64	
180 RSX 40/08	22	30		168	151	146	137	127	113	97	74	
180 RSX 40/09	26	35		192	173	166	157	146	130	110	85	
180 RSX 40/10	30	40		216	194	187	176	164	146	124	95	
180 RSX 40/11	30	40		240	216	208	196	182	162	138	106	
180 RSX 40/12	37	50		264	238	229	216	200	178	152	117	
180 RSX 40/13	37	50		288	259	250	235	218	194	166	127	
				312	281	270	255	237	211	179	138	

DIMENSIONI D'INGOMBRO E PESI - OVERALL DIMENSIONS AND WEIGHTS

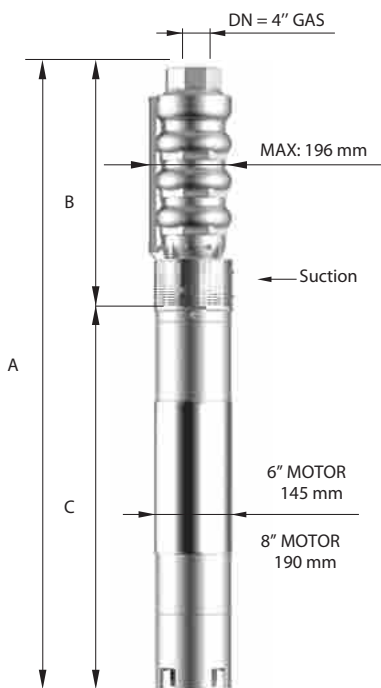

Type	A mm Tri V 400	B mm	C mm Tri	M Kg Tri	P Kg
180 RSX 40/01	947	390	557	19	16
180 RSX 40/02	1168	470	698	27	22
180 RSX 40/03	1301	550	751	60	28
180 RSX 40/04	1441	630	811	65	34
180 RSX 40/05	1641	710	931	75	40
180 RSX 40/06	1781	790	991	83	46
180 RSX 40/07	1941	870	1071	92	52
180 RSX 40/08	2021	950	1071	92	58
180 RSX 40/09	2211	1030	1181	100	64
180 RSX 40/10	2361	1110	1251	108	71
180 RSX 40/11	2441	1190	1251	108	77
180 RSX 40/12	2611	1270	1341	118	83
180 RSX 40/13	2691	1350	1341	118	89

n% = Rendimento della pompa
 n% = Rendement de la pompe
 n% = Pump efficiency
 n% = Rendimiento de la bomba

**Max
73%**

kW/st = Assorbimento per stadio
 kW/st = Absorption par étage
 kW/st = Stage absorption
 kW/st = Potencia absorbida por etapa

**Max
2,8**

Tolleranza alla sabbia 100 g/m³ - Sand tolerance 100 g/m³ - Compatibilità con acqua potabile DM 174 Drinking water compatibility according to DM 174
 Tolleranze secondo UNI ISO 9906 livello 3B - Tolerances according to UNI ISO 9906 grade 3B

acciaio inox microfuso - elevato rendimento - casted stainless steel - high efficiency



8"

180 RSX40

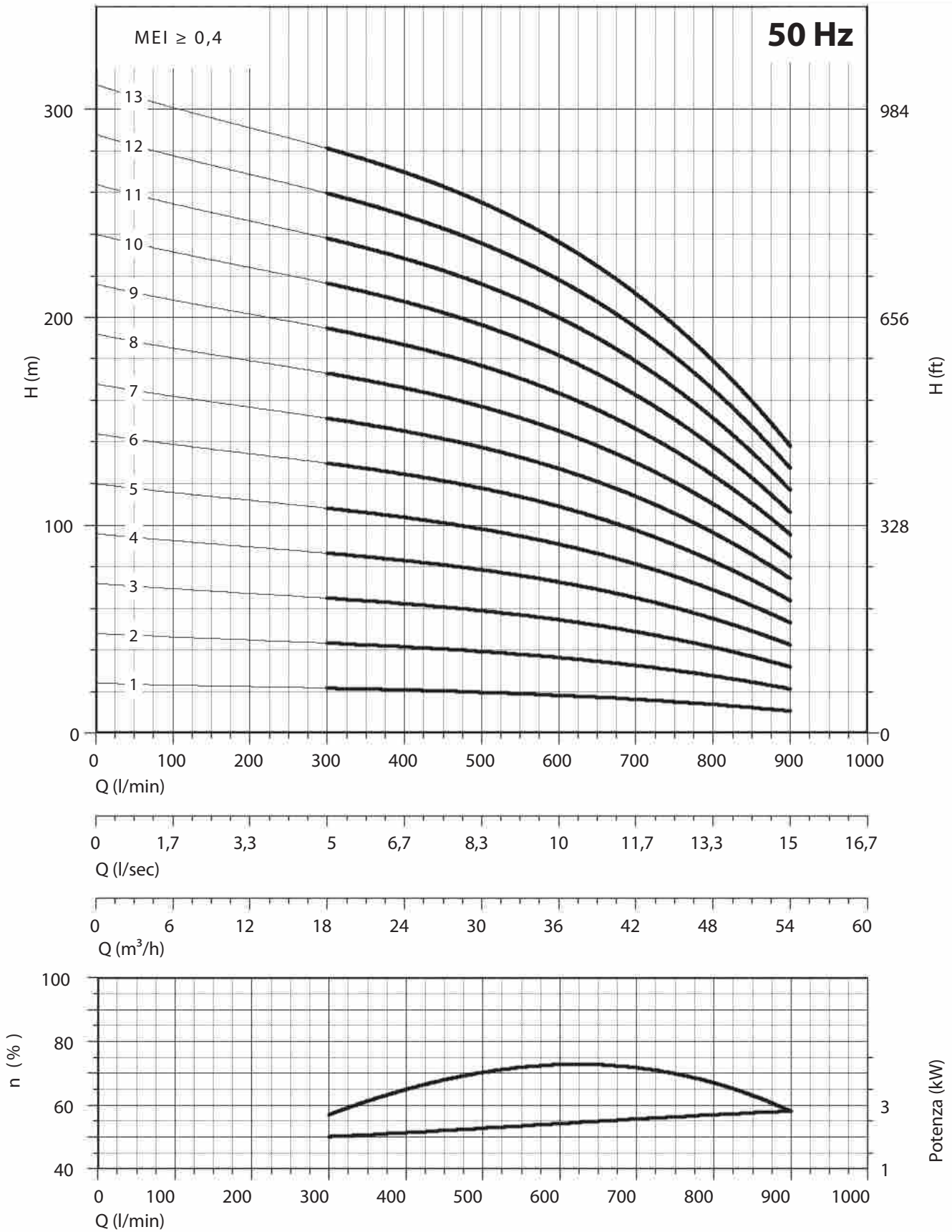

NPSH (m)	25%	50%	75%	100%
180 RSX 40	3,4	3,4	3,8	8

acciaio inox microfuso - elevato rendimento - casted stainless steel - high efficiency

8"

180 RSX40

PANELLI®

CARATTERISTICHE IDRAULICHE - HYDRAULIC PERFORMANCES

Q= Portata - Capacity - Debit **50 Hz n= 2900 min**

Tipo Type	Power		H(m)	0	300	400	500	600	700	800	900	
	kW	HP		l/min	l/sec	m ³ /h	l/min	l/sec	m ³ /h	l/min	l/sec	m ³ /h
				0	5	6,67	8,33	10	11,67	13,33	15	
180 RSX 40/14	44	60		336	302	291	274	255	227	193	148	
180 RSX 40/15	44	60		360	324	312	294	273	243	207	159	
180 RSX 40/16	44	60		384	346	333	314	291	259	221	170	
180 RSX 40/17	55	75		408	367	354	333	309	275	235	180	
180 RSX 40/18	55	75		432	389	374	353	328	292	248	191	
180 RSX 40/19	55	75		456	410	395	372	346	308	262	201	
180 RSX 40/20	55	75		480	432	416	392	364	324	276	212	
180 RSX 40/21	66	90		504	454	437	412	382	340	290	223	
180 RSX 40/22	66	90		528	475	458	431	400	356	304	233	
180 RSX 40/23	66	90		552	497	478	451	419	373	317	244	
180 RSX 40/24	66	90		576	518	499	470	437	389	331	254	
180 RSX 40/25	75	100		600	540	520	490	455	405	345	265	
180 RSX 40/26	75	100		624	562	541	510	473	421	359	276	

DIMENSIONI D'INGOMBRO E PESI - OVERALL DIMENSIONS AND WEIGHTS

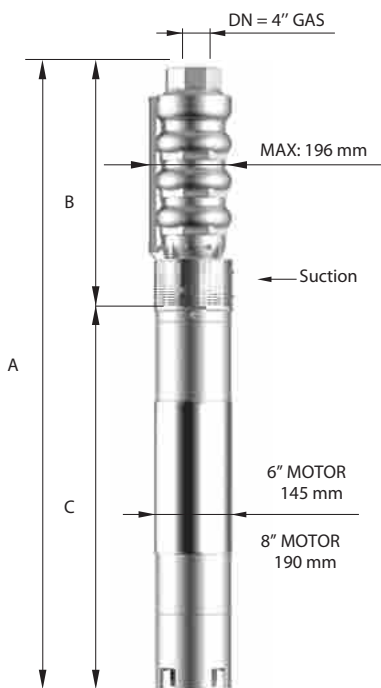

Type	A mm Tri V 400	B mm	C mm Tri	M Kg Tri	P Kg
180 RSX 40/14	2553	1430	1123	178	95
180 RSX 40/15	2633	1510	1123	178	101
180 RSX 40/16	2713	1590	1123	178	107
180 RSX 40/17	2903	1670	1233	200	113
180 RSX 40/18	2983	1750	1233	200	119
180 RSX 40/19	3063	1830	1233	200	125
180 RSX 40/20	3143	1910	1233	200	132
180 RSX 40/21	3293	1990	1303	214	138
180 RSX 40/22	3373	2070	1303	214	144
180 RSX 40/23	3453	2150	1303	214	150
180 RSX 40/24	3533	2230	1303	214	156
180 RSX 40/25	3693	2310	1383	230	162
180 RSX 40/26	3773	2390	1383	230	168

n% = Rendimento della pompa
n% = Rendement de la pompe
n% = Pump efficiency
n% = Rendimiento de la bomba

**Max
73%**

kW/st = Assorbimento per stadio
kW/st = Absorption par étage
kW/st = Stage absorption
kW/st = Potencia absorbida por etapa

**Max
2,8**

Tolleranza alla sabbia 100 g/m³ - Sand tolerance 100 g/m³ - Compatibilità con acqua potabile DM 174 Drinking water compatibility according to DM 174
Tolleranze secondo UNI ISO 9906 livello 3B - Tolerances according to UNI ISO 9906 grade 3B

acciaio inox microfuso - elevato rendimento - casted stainless steel - high efficiency



8"

180 RSX40

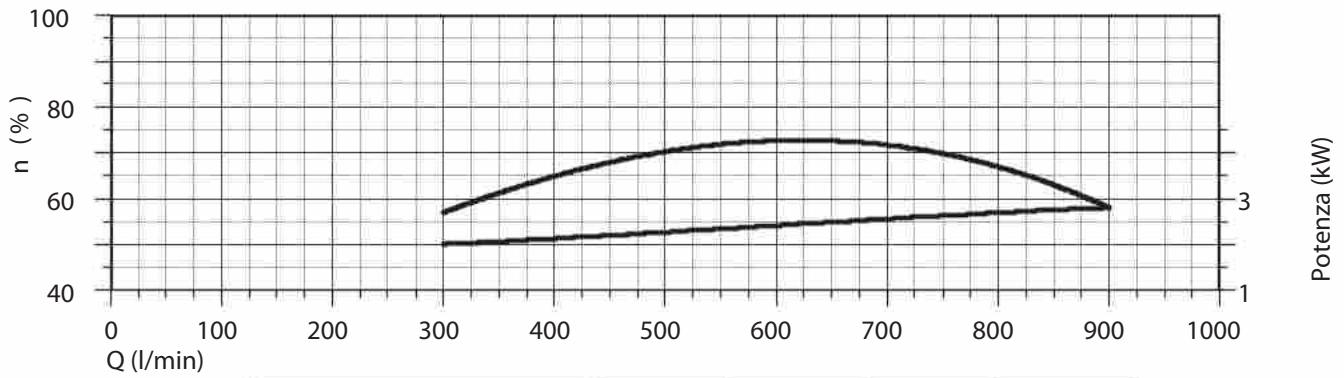
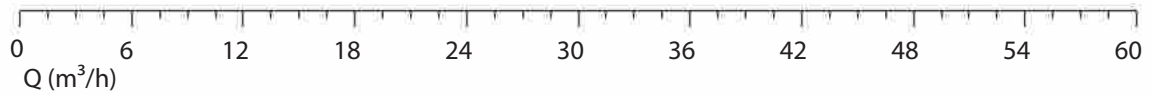
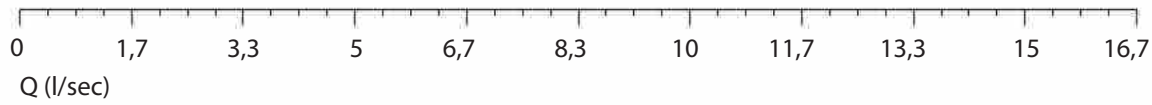
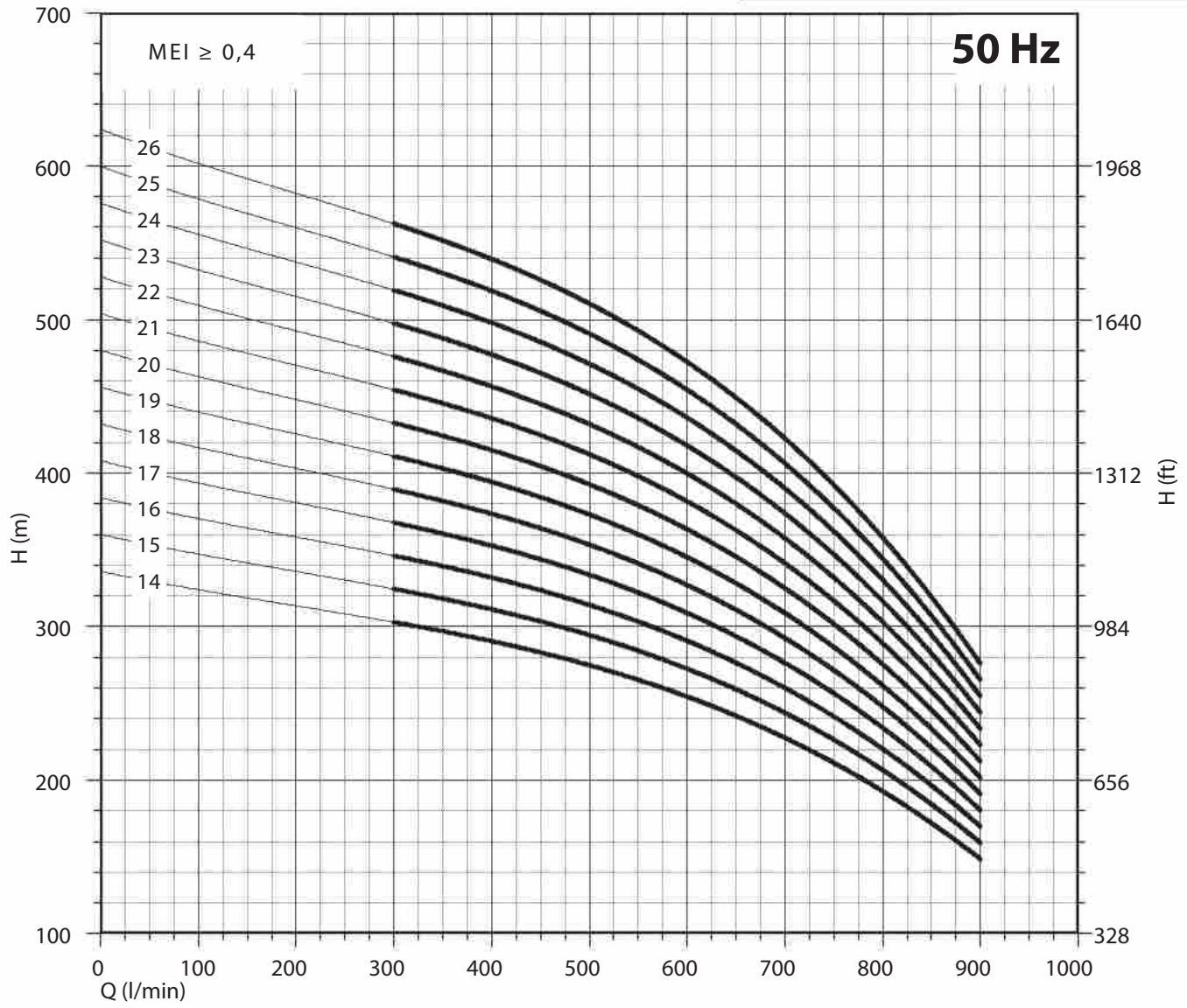

NPSH (m)	25%	50%	75%	100%
180 RSX 40	3,4	3,4	3,8	8

acciaio inox microfuso - elevato rendimento - casted stainless steel - high efficiency

8"

180 RSX50

PANELLI®

CARATTERISTICHE IDRAULICHE - HYDRAULIC PERFORMANCES

Q= Portata - Capacity - Debit **50 Hz n= 2900 min**

Tipo Type	Power		l/min	0	500	600	700	800	900	1000	1100	
	kW	HP		l/sec	0	8,33	10	11,67	13,33	15	16,67	18,33
				m ³ /h	0	30	36	42	48	54	60	66
180 RSX 50/01	4	5,5	H(m)	24	22	20	19	18	16	15	13	
180 RSX 50/02	7,5	10		48	43	41	39	36	33	29	26	
180 RSX 50/03	11	15		72	65	61	58	53	49	44	38	
180 RSX 50/04	15	20		96	86	81	77	71	65	58	51	
180 RSX 50/05	18,5	25		120	108	101	96	89	81	73	64	
180 RSX 50/06	22	30		144	129	122	116	107	98	87	77	
180 RSX 50/07	26	35		168	151	142	135	124	114	102	89	
180 RSX 50/08	30	40		192	172	162	154	142	130	116	102	
180 RSX 50/09	30	40		216	194	182	173	160	146	131	115	
180 RSX 50/10	37	50		240	215	203	193	178	163	145	128	
180 RSX 50/11	37	50		264	237	223	212	195	179	160	140	
180 RSX 50/12	44	60		288	258	243	231	213	195	174	153	
180 RSX 50/13	44	60		312	280	263	250	231	211	189	166	

DIMENSIONI D'INGOMBRO E PESI - OVERALL DIMENSIONS AND WEIGHTS

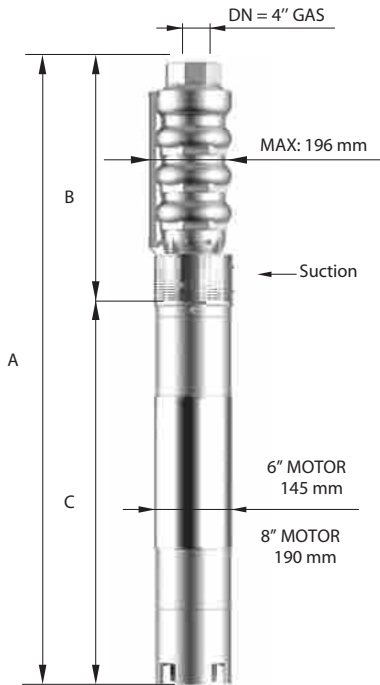

Type	A mm Tri V 400	B mm	C mm Tri	M Kg Tri	P Kg
180 RSX 50/01	1044	398	646	40	16
180 RSX 50/02	1187	486	701	55	23
180 RSX 50/03	1385	574	811	65	29
180 RSX 50/04	1593	662	931	75	36
180 RSX 50/05	1741	750	991	83	42
180 RSX 50/06	1909	838	1071	92	49
180 RSX 50/07	2107	926	1181	100	55
180 RSX 50/08	2265	1014	1251	108	62
180 RSX 50/09	2353	1102	1251	108	68
180 RSX 50/10	2531	1190	1341	118	75
180 RSX 50/11	2619	1278	1341	118	81
180 RSX 50/12	2489	1366	1123	178	88
180 RSX 50/13	2577	1454	1123	178	94

n% = Rendimento della pompa
 n% = Rendement de la pompe
 n% = Pump efficiency
 n% = Rendimiento de la bomba

**Max
73%**

kW/st = Assorbimento per stadio
 kW/st = Absorption par étage
 kW/st = Stage absorption
 kW/st = Potencia absorbida por etapa

**Max
3,4**

Tolleranza alla sabbia 100 g/m³ - Sand tolerance 100 g/m³ - Compatibilità con acqua potabile DM 174 Drinking water compatibility according to DM 174
 Tolleranze secondo UNI ISO 9906 livello 3B - Tolerances according to UNI ISO 9906 grade 3B

acciaio inox microfuso - elevato rendimento - casted stainless steel - high efficiency

PANELLI®

8"

180 RSX50

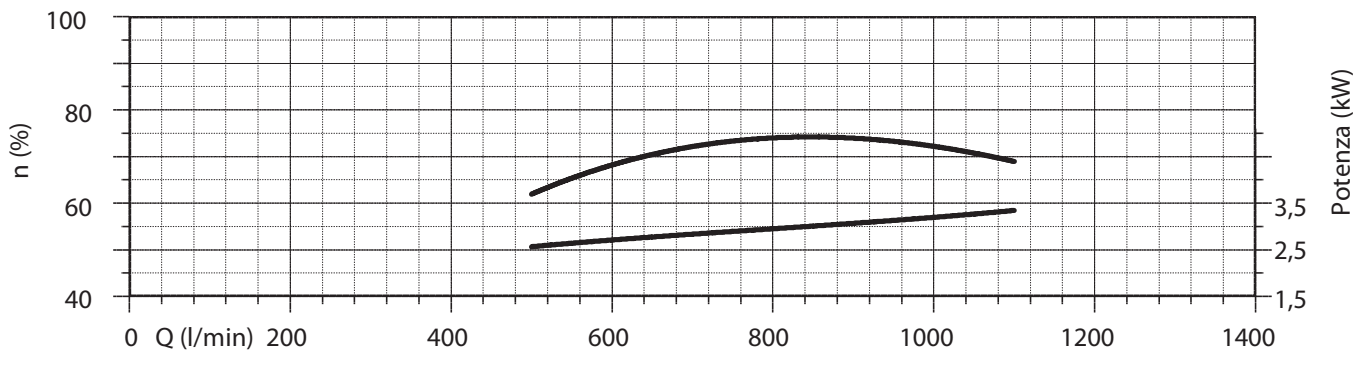
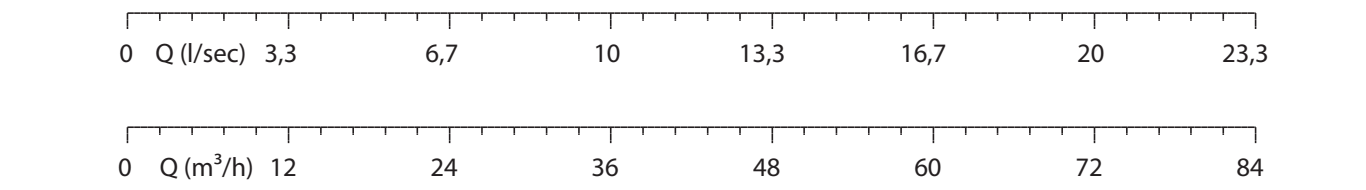
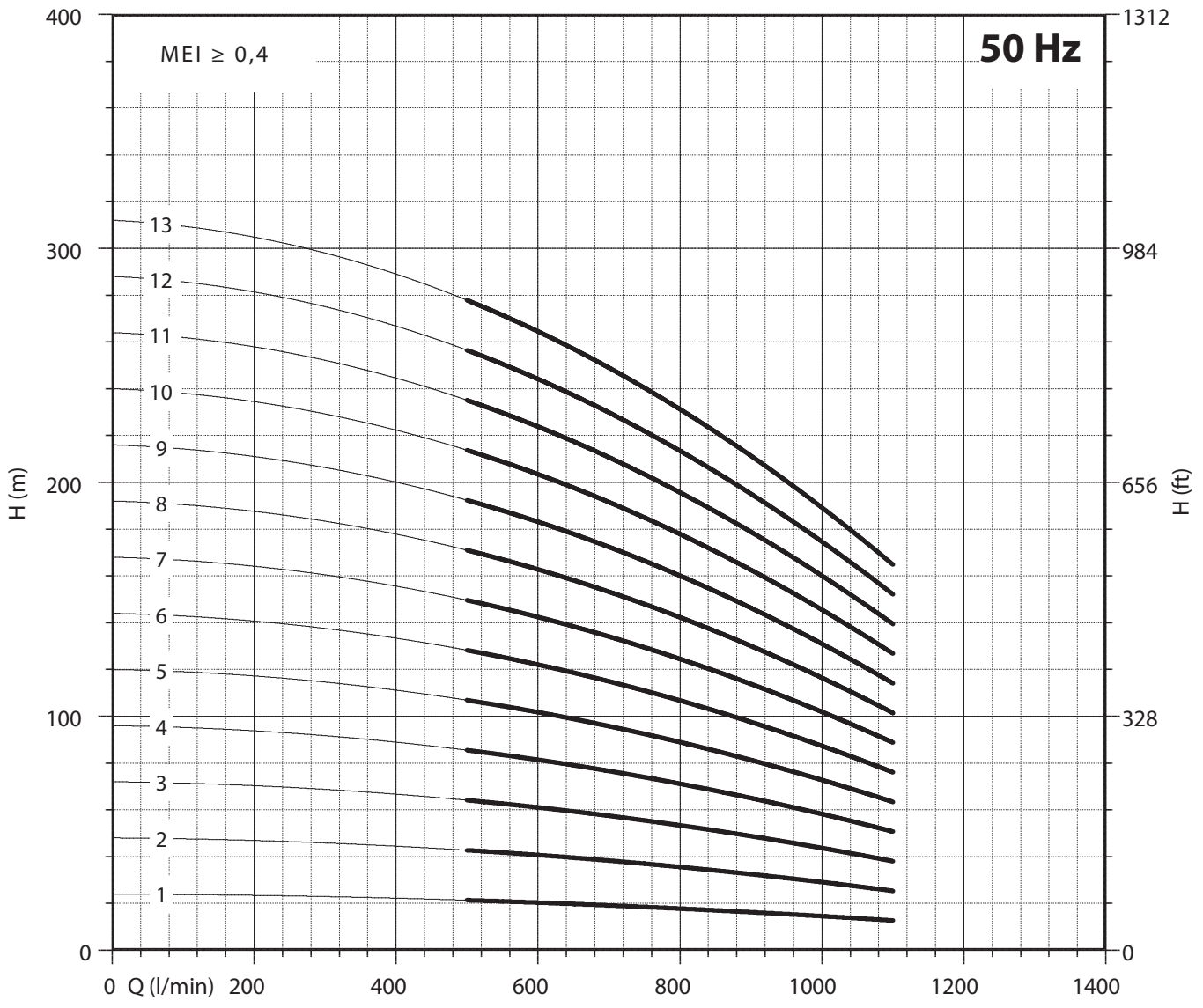

NPSH (m)	25%	50%	75%	100%
180 RSX 50	3,5	3,5	6	8

acciaio inox microfuso - elevato rendimento - casted stainless steel - high efficiency

8"

180 RSX50

PANELLI®

CARATTERISTICHE IDRAULICHE - HYDRAULIC PERFORMANCES

Q= Portata - Capacity - Debit **50 Hz n= 2900 min**

Tipo Type	Power		l/min	0	500	600	700	800	900	1000	1100	
	kW	HP		l/sec	0	8,33	10	11,67	13,33	15	16,67	18,33
				m³/h	0	30	36	42	48	54	60	66
180 RSX 50/14	55	75	H(m)	336	301	284	270	249	228	203	179	
180 RSX 50/15	55	75		360	323	304	289	266	244	218	191	
180 RSX 50/16	55	75		384	344	324	308	284	260	232	204	
180 RSX 50/17	66	90		408	366	344	327	302	276	247	217	
180 RSX 50/18	66	90		432	387	365	347	320	293	261	230	
180 RSX 50/19	66	90		456	409	385	366	337	309	276	242	
180 RSX 50/20	66	90		480	430	405	385	355	325	290	255	
180 RSX 50/21	75	100		504	452	425	404	373	341	305	268	
180 RSX 50/22	75	100		528	473	446	424	391	358	319	281	
180 RSX 50/23	92	125		552	495	466	443	408	374	334	293	
180 RSX 50/24	92	125		576	516	486	462	426	390	348	306	
180 RSX 50/25	92	125		600	538	506	481	444	406	363	319	
180 RSX 50/26	92	125		624	559	527	501	462	423	377	332	

DIMENSIONI D'INGOMBRO E PESI - OVERALL DIMENSIONS AND WEIGHTS

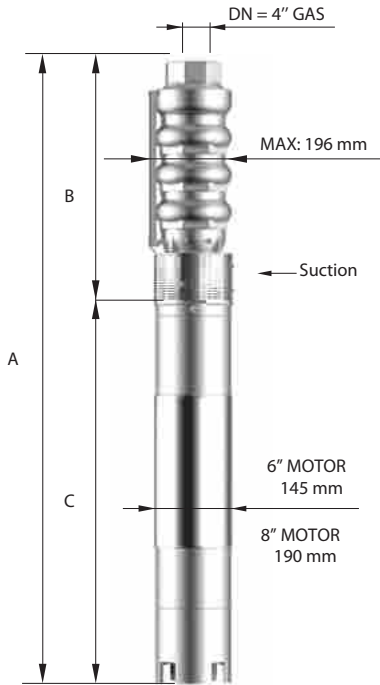

Type	A mm Tri V 400	B mm	C mm Tri	M Kg Tri	P Kg
180 RSX 50/14	2775	1542	1233	200	101
180 RSX 50/15	2863	1630	1233	200	107
180 RSX 50/16	2951	1718	1233	200	114
180 RSX 50/17	3109	1806	1303	214	120
180 RSX 50/18	3197	1894	1303	214	127
180 RSX 50/19	3285	1982	1303	214	133
180 RSX 50/20	3373	2070	1303	214	140
180 RSX 50/21	3541	2158	1383	230	146
180 RSX 50/22	3629	2246	1383	230	153
180 RSX 50/23	3917	2334	1583	270	159
180 RSX 50/24	4005	2422	1583	270	166
180 RSX 50/25	4093	2510	1583	270	172
180 RSX 50/26	4181	2598	1583	270	179

n% = Rendimento della pompa
 n% = Rendement de la pompe
 n% = Pump efficiency
 n% = Rendimiento de la bomba

**Max
73%**

kW/st = Assorbimento per stadio
 kW/st = Absorption par étage
 kW/st = Stage absorption
 kW/st = Potencia absorbida por etapa

**Max
3,4**

Tolleranza alla sabbia 100 g/m³ - Sand tolerance 100 g/m³ - Compatibilità con acqua potabile DM 174 Drinking water compatibility according to DM 174
 Tolleranze secondo UNI ISO 9906 livello 3B - Tolerances according to UNI ISO 9906 grade 3B

acciaio inox microfuso - elevato rendimento - casted stainless steel - high efficiency

PANELLI®

8"

180 RSX50

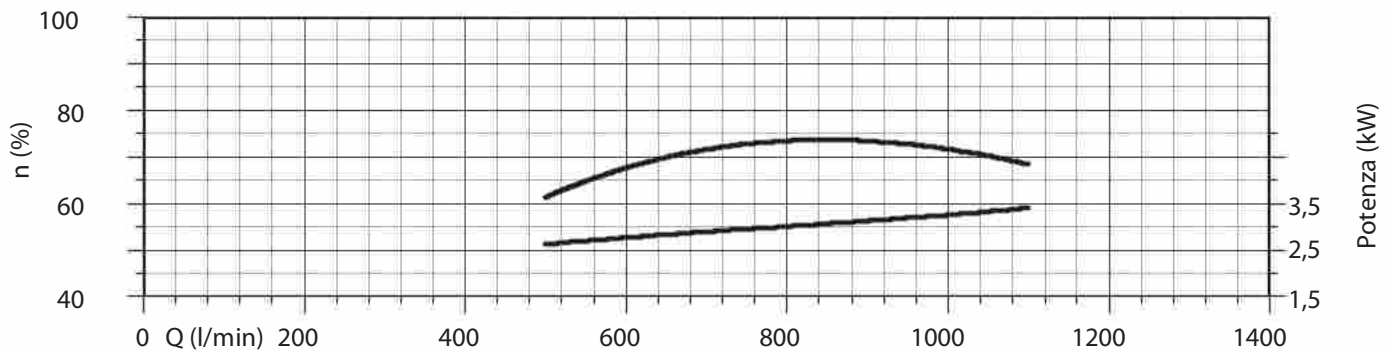
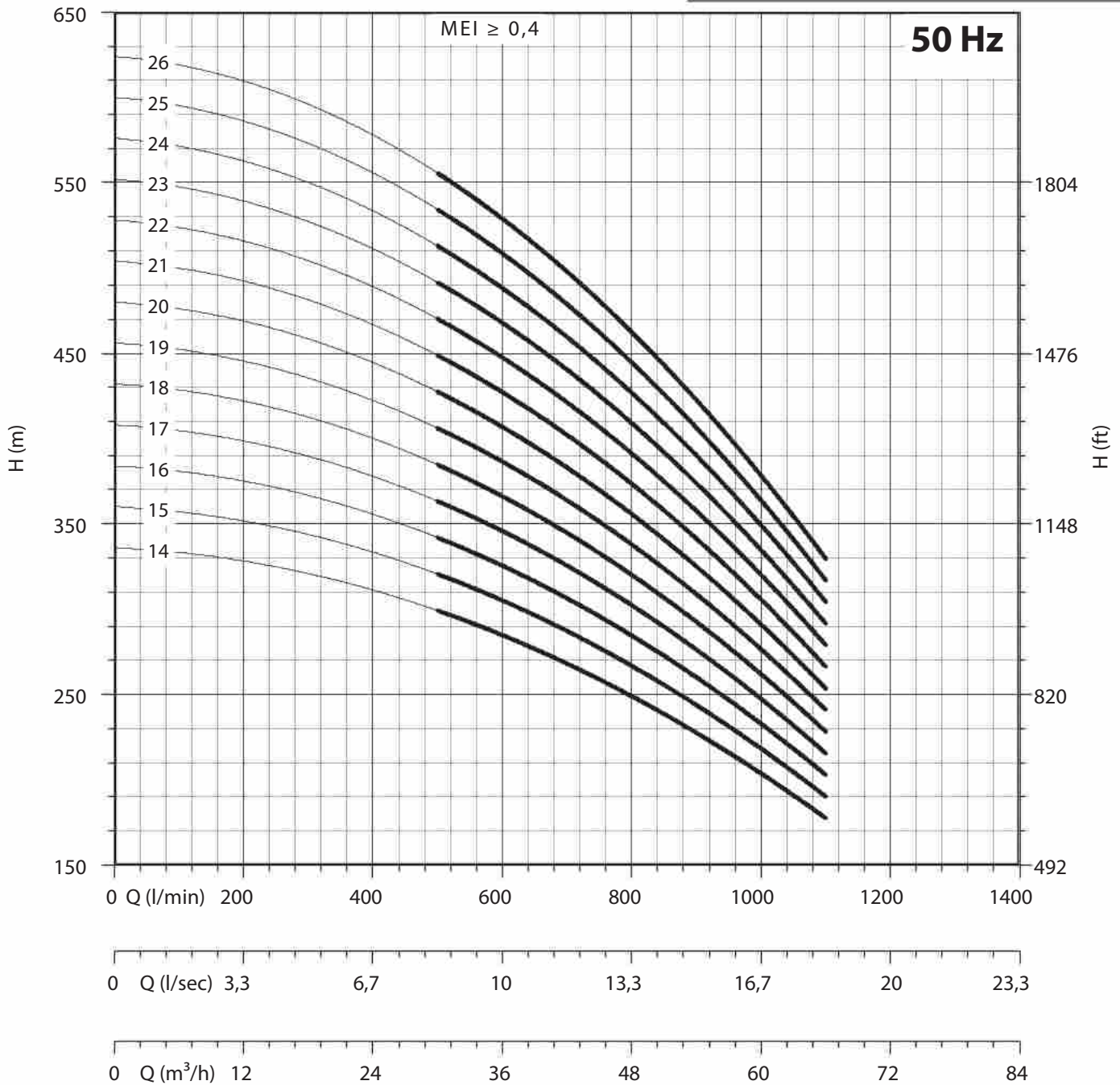

NPSH (m)	25%	50%	75%	100%
180 RSX 50	3,5	3,5	6	8

6" - 8" RSX - 33

acciaio inox microfuso - elevato rendimento - casted stainless steel - high efficiency

8"

180 RSX60

PANELLI®

CARATTERISTICHE IDRAULICHE - HYDRAULIC PERFORMANCES

Q= Portata - Capacity - Debit **50 Hz n= 2900 min**

Tipo Type	Power		H(m)	0	600	800	900	1000	1100	1200	1300
	kW	HP		l/min	l/sec	m ³ /h					
180 RSX 60/01				4	5,5	23	20	18	17	15	14
180 RSX 60/02	7,5	10		46	40	36	33	30	27	24	21
180 RSX 60/03	11	15	69	60	54	50	45	41	36	32	
180 RSX 60/04	15	20	92	80	72	66	60	54	48	42	
180 RSX 60/05	18,5	25	115	100	90	83	75	68	60	53	
180 RSX 60/06	22	30	138	120	108	99	90	81	72	63	
180 RSX 60/07	26	35	161	140	126	116	105	95	84	74	
180 RSX 60/08	30	40	184	160	144	132	120	108	96	84	
180 RSX 60/09	37	50	207	180	162	149	135	122	108	95	
180 RSX 60/10	37	50	230	200	180	165	150	135	120	105	
180 RSX 60/11	44	60	253	220	198	182	165	149	132	116	
180 RSX 60/12	44	60	276	240	216	198	180	162	144	126	
180 RSX 60/13	55	75	299	260	234	215	195	176	156	137	

DIMENSIONI D'INGOMBRO E PESI - OVERALL DIMENSIONS AND WEIGHTS

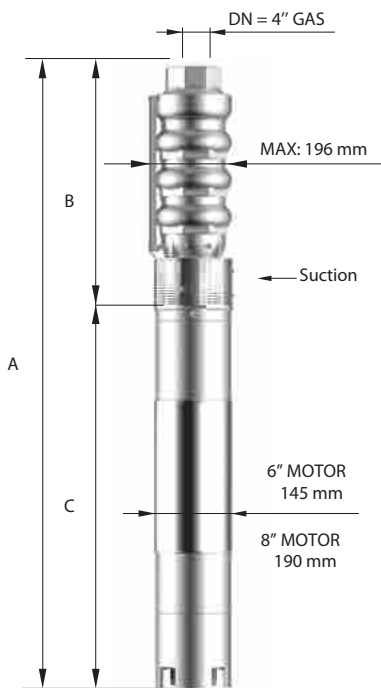

Type	A mm Tri V 400	B mm	C mm Tri	M Kg Tri	P Kg
180 RSX 60/01	1044	398	646	40	16
180 RSX 60/02	1187	486	701	55	23
180 RSX 60/03	1385	574	811	65	29
180 RSX 60/04	1593	662	931	75	36
180 RSX 60/05	1741	750	991	83	42
180 RSX 60/06	1909	838	1071	92	49
180 RSX 60/07	2107	926	1181	100	55
180 RSX 60/08	2265	1014	1251	108	62
180 RSX 60/09	2443	1102	1341	118	68
180 RSX 60/10	2531	1190	1341	118	75
180 RSX 60/11	2401	1278	1123	178	81
180 RSX 60/12	2489	1366	1123	178	88
180 RSX 60/13	2687	1454	1233	200	94

n% = Rendimento della pompa
 n% = Rendement de la pompe
 n% = Pump efficiency
 n% = Rendimiento de la bomba

**Max
74,5%**

kW/st = Assorbimento per stadio
 kW/st = Absorption par étage
 kW/st = Stage absorption
 kW/st = Potencia absorbida por etapa

**Max
3,8**

Tolleranza alla sabbia 100 g/m³ - Sand tolerance 100 g/m³ - Compatibilità con acqua potabile DM 174 Drinking water compatibility according to DM 174
 Tolleranze secondo UNI ISO 9906 livello 3B - Tolerances according to UNI ISO 9906 grade 3B

acciaio inox microfuso - elevato rendimento - casted stainless steel - high efficiency

PANELLI®

8"

180 RSX60

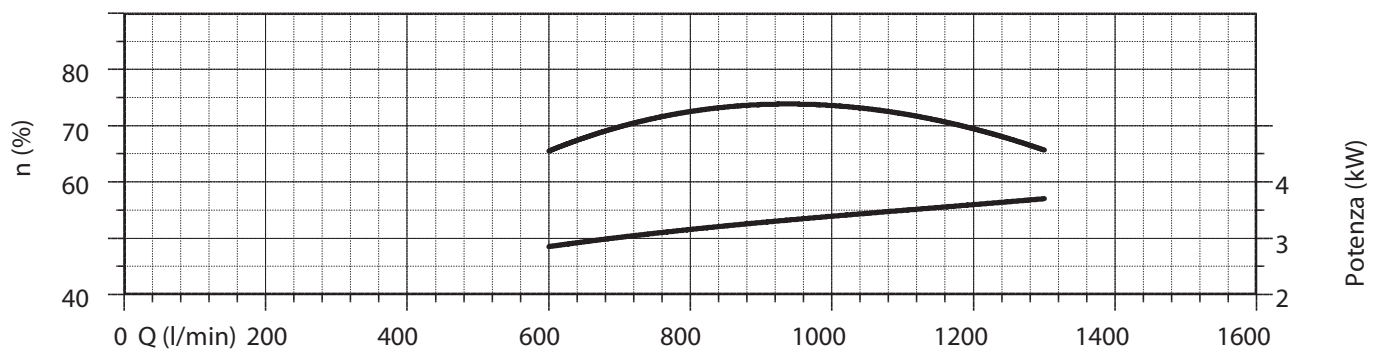
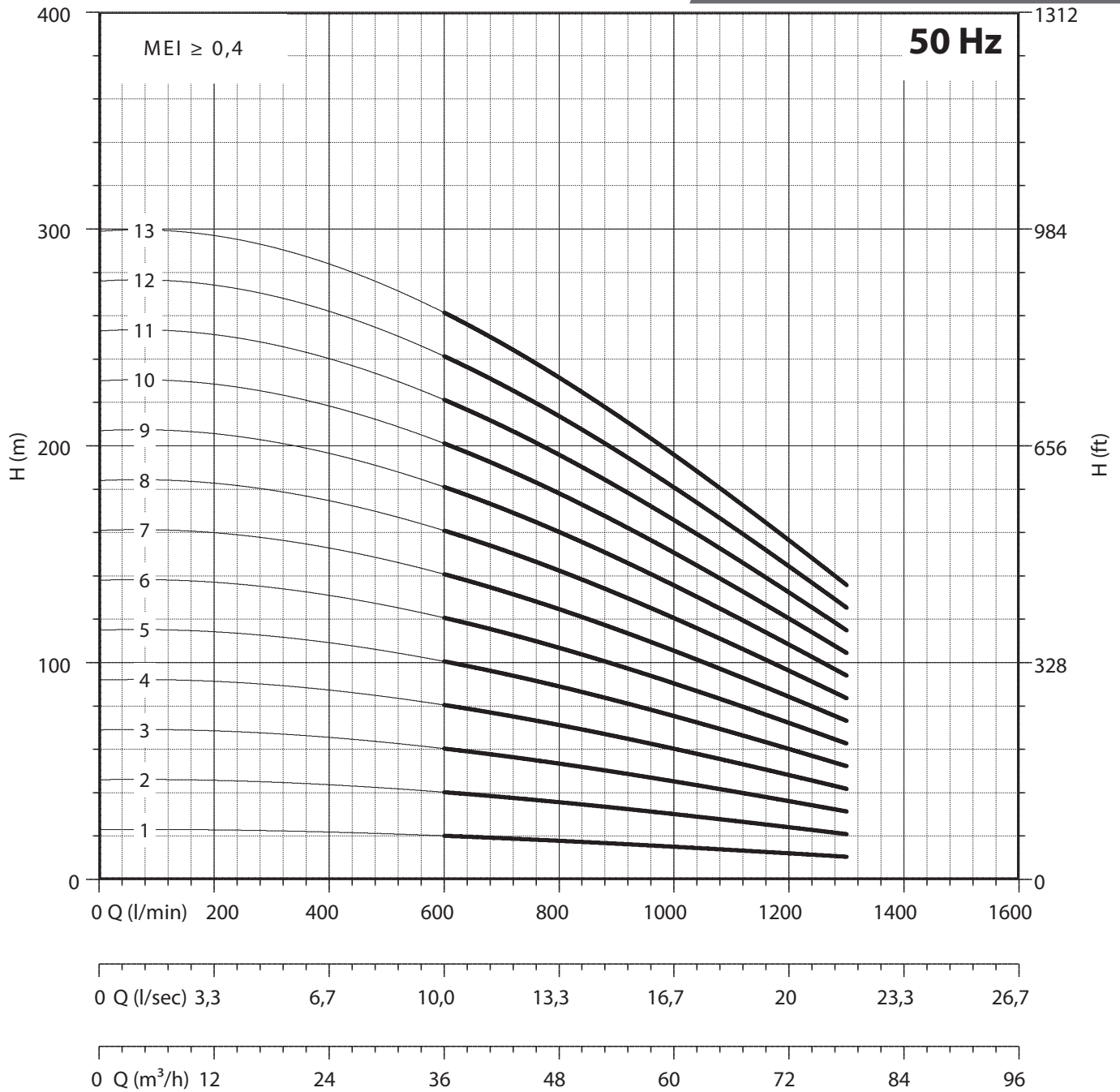

NPSH (m)	25%	50%	75%	100%
180 RSX 60	3,4	3,4	6	8

acciaio inox microfuso - elevato rendimento - casted stainless steel - high efficiency

8"

180 RSX60

PANELLI®

CARATTERISTICHE IDRAULICHE - HYDRAULIC PERFORMANCES

Q= Portata - Capacity - Debit **50 Hz n= 2900 min**

Tipo Type	Power		H(m)	0	600	800	900	1000	1100	1200	1300	
	kW	HP		l/min	l/sec	m ³ /h	l/min	l/sec	m ³ /h	l/min	l/sec	m ³ /h
				0	10	13,33	15	16,67	18,33	20	21,67	
180 RSX 60/14	55	75	322	280	252	232	210	190	168	148		
180 RSX 60/15	66	90	345	300	270	248	225	203	180	158		
180 RSX 60/16	66	90	368	320	288	265	240	217	192	169		
180 RSX 60/17	66	90	391	340	306	281	255	230	204	179		
180 RSX 60/18	75	100	414	360	324	298	270	244	216	190		
180 RSX 60/19	75	100	437	380	342	314	285	257	228	200		
180 RSX 60/20	75	100	460	400	360	331	300	271	240	211		
180 RSX 60/21	92	125	483	420	378	347	315	284	252	221		
180 RSX 60/22	92	125	506	440	396	364	330	298	264	232		
180 RSX 60/23	92	125	529	460	414	380	345	311	276	242		
180 RSX 60/24	92	125	552	480	432	397	360	325	288	253		
180 RSX 60/25	92	125	575	500	450	413	375	338	300	263		

DIMENSIONI D'INGOMBRO E PESI - OVERALL DIMENSIONS AND WEIGHTS

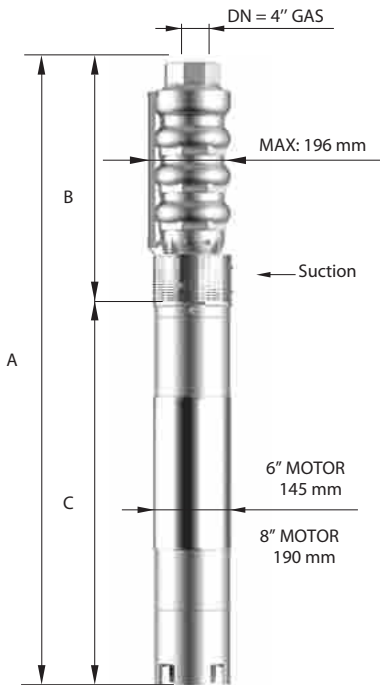

Type	A mm Tri V 400	B mm	C mm Tri	M Kg Tri	P Kg
180 RSX 60/14	2775	1542	1233	200	101
180 RSX 60/15	2933	1630	1303	214	107
180 RSX 60/16	3021	1718	1303	214	114
180 RSX 60/17	3109	1806	1303	214	120
180 RSX 60/18	3277	1894	1383	230	127
180 RSX 60/19	3365	1982	1383	230	133
180 RSX 60/20	3453	2070	1383	230	140
180 RSX 60/21	3741	2158	1583	270	146
180 RSX 60/22	3829	2246	1583	270	153
180 RSX 60/23	3917	2334	1583	270	159
180 RSX 60/24	4005	2422	1583	270	166
180 RSX 60/25	4093	2510	1583	270	172

n% = Rendimento della pompa
n% = Rendement de la pompe
n% = Pump efficiency
n% = Rendimiento de la bomba

**Max
74,5%**

kW/st = Assorbimento per stadio
kW/st = Absorption par étage
kW/st = Stage absorption
kW/st = Potencia absorbida por etapa

**Max
3,8**

Tolleranza alla sabbia 100 g/m³ - Sand tolerance 100 g/m³ - Compatibilità con acqua potabile DM 174 Drinking water compatibility according to DM 174
Tolleranze secondo UNI ISO 9906 livello 3B - Tolerances according to UNI ISO 9906 grade 3B

acciaio inox microfuso - elevato rendimento - casted stainless steel - high efficiency



8"

180 RSX60

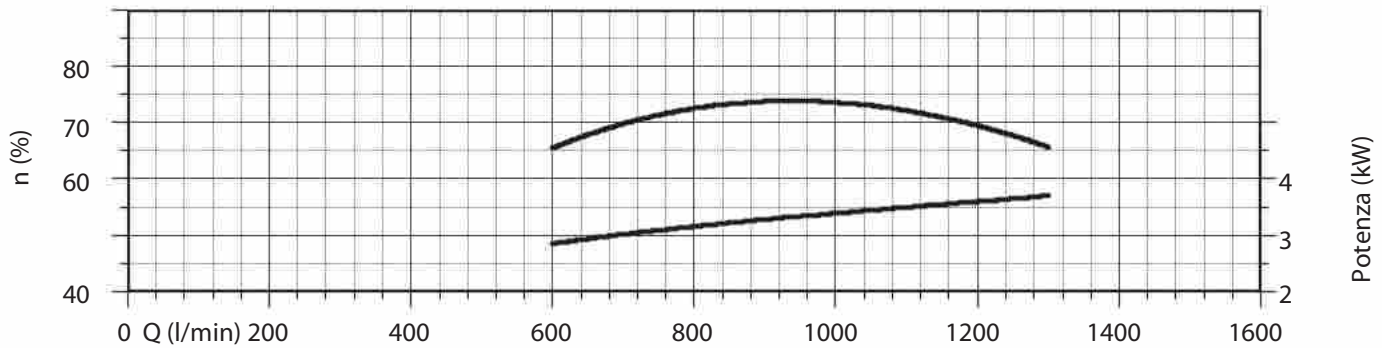
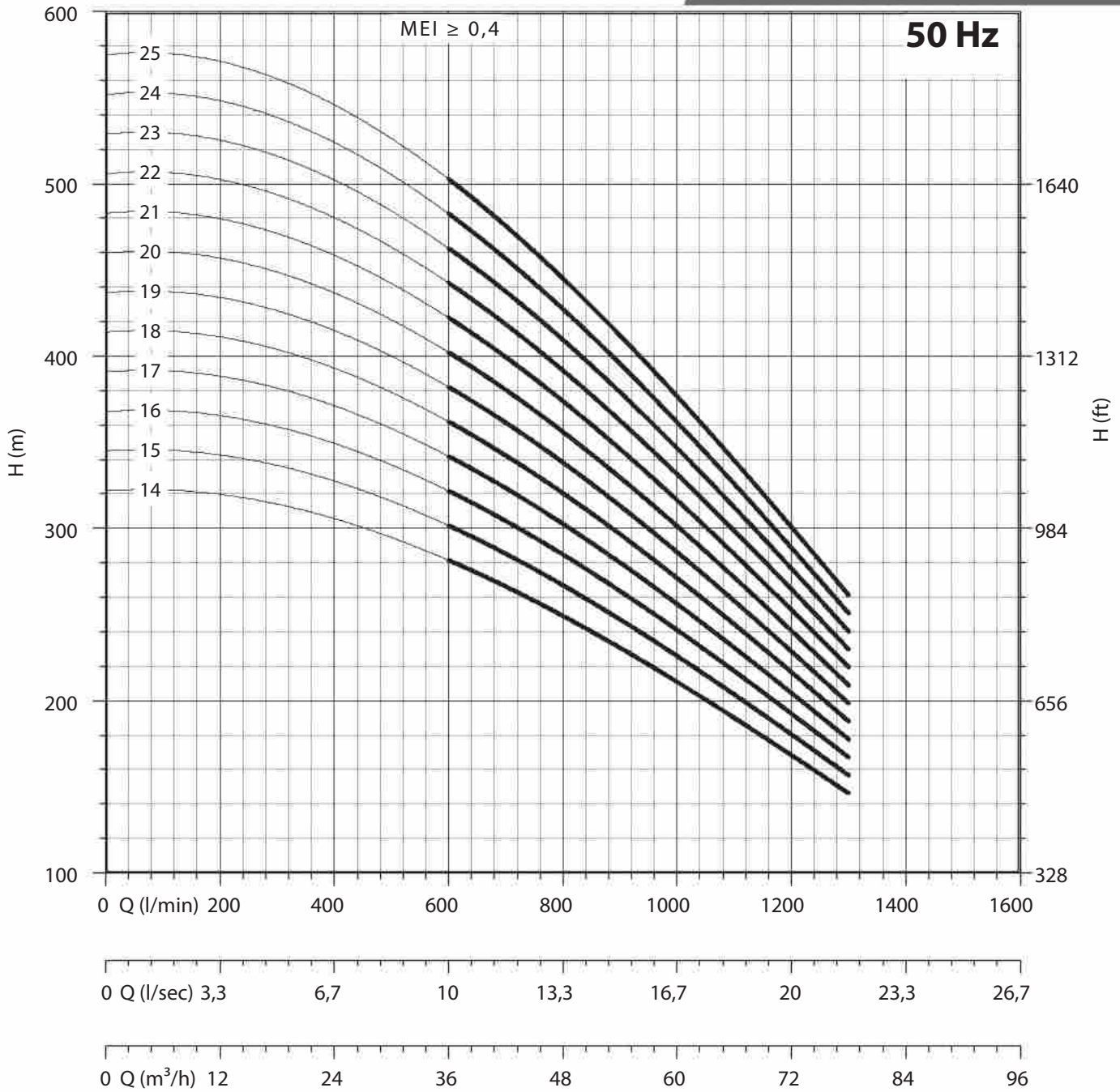

NPSH (m)	25%	50%	75%	100%
180 RSX 60	3,4	3,4	6	8



italian excellence since 1906

Note/notes

A series of horizontal dotted lines for taking notes, spanning the width of the page.



italian excellence since 1906

6" 8" 140 RSX | **50**Hz
180 RSX

POMPA SOMMERSA RADIALE INOX
RADIAL SUBMERSIBLE PUMP - INOX



Casted

RICAMBI
TABELLE MATERIALI

SPARE PARTS
MATERIAL CHARTS

acciaio inox microfuso - elevato rendimento - casted stainless steel - high efficiency

6" - 8"
140 - 180 RSX

PANELLI®

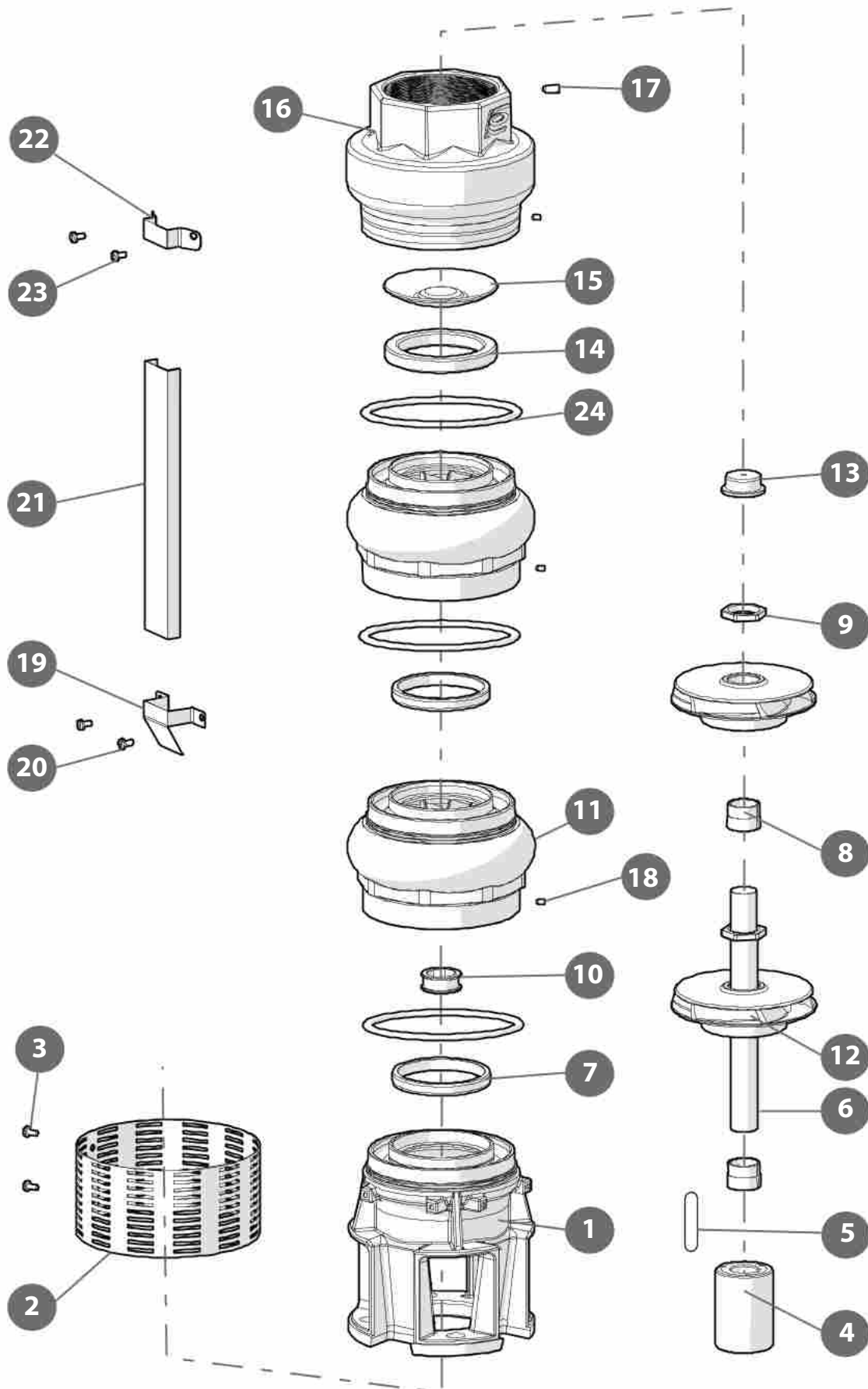



6" - 8"

140 - 180 RSX

140 - 180 RSX

N. CODE	DESCRIZIONE (italiano)	MATERIALE (italiano)	DESCRIZIONE (english)	MATERIAL (english)
1	GABBIA ASPIRAZIONE	ACCIAIO INOX AISI 304	SUCTION CAGE	AISI 304
2	SUCCHERUOLA	ACCIAIO INOX AISI 304	SUCTION STRAINER	AISI 304
3	VITI PER SUCCHERUOLA	ACCIAIO INOX AISI 304	SCREW FOR SUCTION STRAINER	AISI 304
4	GIUNTO DI TRAINO	ACCIAIO INOX AISI 304	JOINT	AISI 304
5	LINGUETTA	ACCIAIO INOX AISI 304	KEY	AISI 304
6	ALBERO POMPA	ACCIAIO INOX AISI 304	PUMP SHAFT	AISI 304
7	ANELLO USURA	GOMMA NBR	USURY RING	NBR
8	CONO	ACCIAIO INOX AISI 304	CONE	AISI 304
9	GHIERA ESAGONALE	ACCIAIO INOX AISI 304	HEXAGONAL RING	AISI 304
10	BRONZINA	GOMMA NBR	BEARING BUSH	NBR
11	DIFFUSORE	ACCIAIO INOX AISI 304	DIFFUSER	AISI 304
12	GIRANTE	ACCIAIO INOX AISI 202	IMPELLER	AISI 202
13	CONTROSOSPENSIONE	PTFE+25% CARBONE	COUNTERTHRUST	PTFE+25% CARBON
14	GUARNIZIONE FARFALLA	GOMMA NBR	GASKET VALVE	NBR
15	FARFALLA	ACCIAIO INOX AISI 304	CAP VALVE	AISI 304
16	MANDATA	ACCIAIO INOX AISI 304	DELIVERY BOWL	AISI 304
17	GRANO ANTISVITAMENTO	ACCIAIO INOX AISI 304	SCREWS FOR LOCKING	AISI 304
18	GRANO BLOCCA DIFFUSORE	ACCIAIO INOX AISI 304	SCREWS FOR LOCKING DIFFUSER	AISI 304
19	STAFFETTA INFERIORE	ACCIAIO INOX AISI 304	LOWER FLANGE	AISI 304
20	VITI PER STAFFETTA INFERIORE	ACCIAIO INOX AISI 304	SCREW FOR LOWER FLANGE	AISI 304
21	COPRICAVO	ACCIAIO INOX AISI 304	COVER CABLE	AISI 304
22	STAFFETTA SUPERIORE	ACCIAIO INOX AISI 304	UPPER FLANGE	AISI 304
23	VITI STAFFETTA SUPERIORE	ACCIAIO INOX AISI 304	SCREW FOR UPPER FLANGE	AISI 304
24	O-RING	GOMMA NBR	O-RING	NBR

N. CODE	DESCRIPTION (Français)	MATÉRIEL (Français)	DESCRIPCIÓN (español)	MATERIAL (español)
1	CAGE D'ASPIRATION	ACIER INOXYDABLE AISI 304	CUERPO DE ASPIRACION	ACERO INOXYDABLE AISI 304
2	CREPINE	ACIER INOXYDABLE AISI 304	REJILLA	ACERO INOXYDABLE AISI 304
3	VIS POUR CREPINE	ACIER INOXYDABLE AISI 304	TORNILLOS REJILLA	ACERO INOXYDABLE AISI 304
4	JOINT	ACIER INOXYDABLE AISI 304	ACOPLAMIENTO	ACERO INOXYDABLE AISI 304
5	KEY	ACIER INOXYDABLE AISI 304	KEY	ACERO INOXYDABLE AISI 304
6	ABRE POMPE	ACIER INOXYDABLE AISI 304	EJE DE BOMBA	ACERO INOXYDABLE AISI 304
7	BAGUE D'USURE	CAOUTCHOUC	ANILLO DE DESGASTE	GOMA
8	CONE	ACIER INOXYDABLE AISI 304	CONO	ACERO INOXYDABLE AISI 304
9	BAGUE HEXAGONE	ACIER INOXYDABLE AISI 304	ANILLO HEXAGONAL	ACERO INOXYDABLE AISI 304
10	COUSSINET	CAOUTCHOUC	COJINETE	GOMA
11	DIFFUSEUR	ACIER INOXYDABLE AISI 304	DIFUSOR	ACERO INOXYDABLE AISI 304
12	ROUE	ACIER INOXYDABLE AISI 202	IMPULSOR	ACERO INOXYDABLE AISI 202
13	CONTRESUSPENSION	PTFE+25% CHARBON	CONTRA-SUSPENSION	PTFE + 25% GRAPHITE
14	GASKET VALVE	CAOUTCHOUC	JUNTA DE VALVULA	GOMA
15	PLAT	ACIER INOXYDABLE AISI 304	VALVULA	ACERO INOXYDABLE AISI 304
16	REFOULEMENT	ACIER INOXYDABLE AISI 304	CUERPO DE IMPULSION	ACERO INOXYDABLE AISI 304
17	VIS DE BLOCAGE	ACIER INOXYDABLE AISI 304	TORNILLO DE BLOQUEO	ACERO INOXYDABLE AISI 304
18	VIS DE BLOCAGE DIFFUSEUR	ACIER INOXYDABLE AISI 304	TORNILLO DE BLOQUEO DIFUSOR	ACERO INOXYDABLE AISI 304
19	BRIDE INFERIEURE	ACIER INOXYDABLE AISI 304	GRAPA INFERIOR	ACERO INOXYDABLE AISI 304
20	VIS POUR BRIDE INFERIEURE	ACIER INOXYDABLE AISI 304	TORNILLO PARA GRAPA INFERIOR	ACERO INOXYDABLE AISI 304
21	PROTECTOR CABLE	ACIER INOXYDABLE AISI 304	PARACABLE	ACERO INOXYDABLE AISI 304
22	BRIDE SUPERIEURE	ACIER INOXYDABLE AISI 304	GRAPA SUPERIOR	ACERO INOXYDABLE AISI 304
23	VIS POUR BRIDE SUPERIEURE	ACIER INOXYDABLE AISI 304	TORNILLO PARA GRAPA SUPERIOR	ACERO INOXYDABLE AISI 304
24	O-RING	CAOUTCHOUC	ANILLO TORICO	GOMA

acciaio inox microfuso - elevato rendimento - casted stainless steel - high efficiency

6" - 8"
140 - 180 RSX

PANELLI®

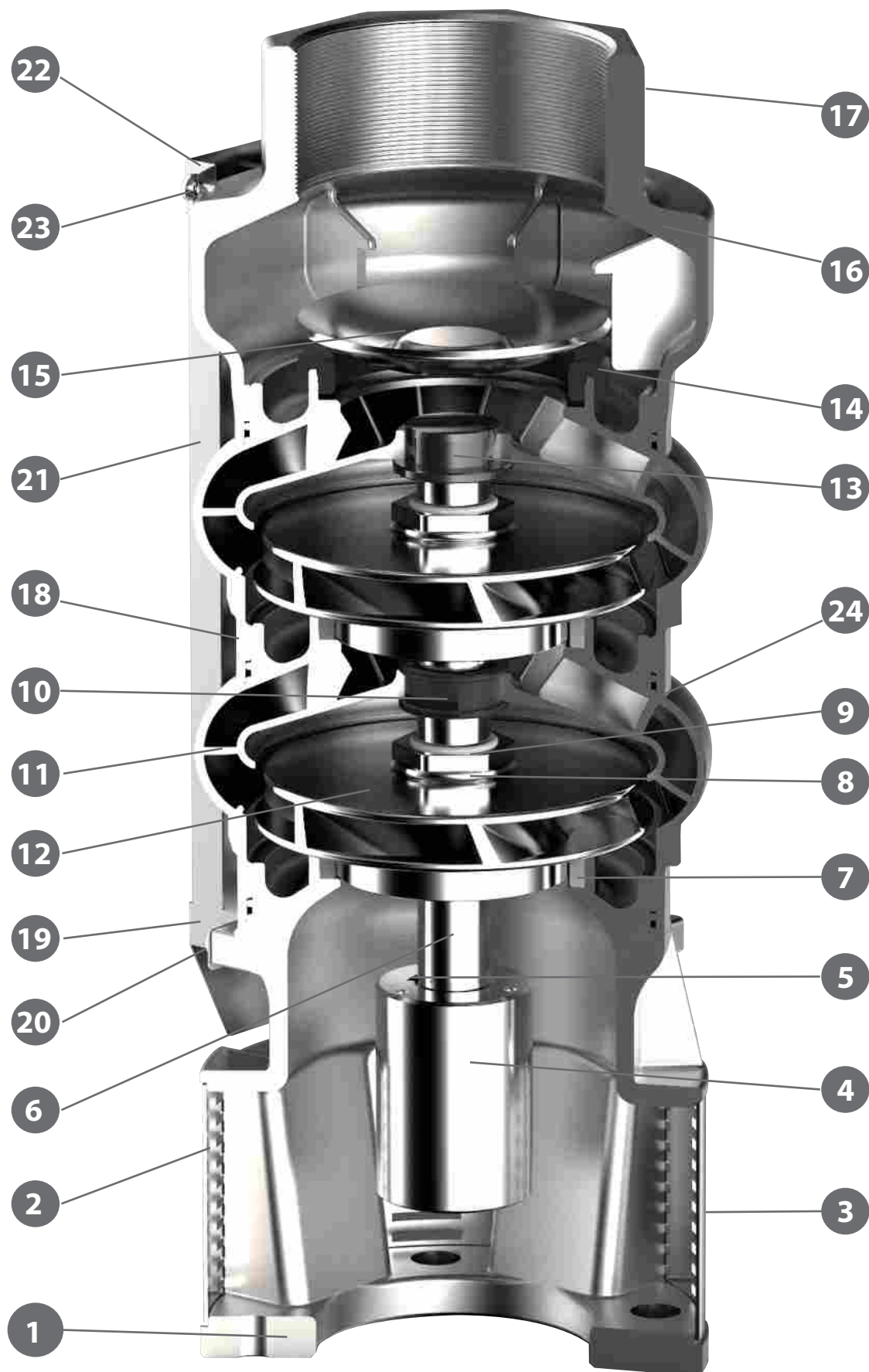



6" - 8"

140 - 180 RSX

140 - 180 RSX

N. CODE	DESCRIZIONE (italiano)	MATERIALE (italiano)	DESCRIZIONE (english)	MATERIAL (english)
1	GABBIA ASPIRAZIONE	ACCIAIO INOX AISI 304	SUCTION CAGE	AISI 304
2	SUCCHERUOLA	ACCIAIO INOX AISI 304	SUCTION STRAINER	AISI 304
3	VITI PER SUCCHERUOLA	ACCIAIO INOX AISI 304	SCREW FOR SUCTION STRAINER	AISI 304
4	GIUNTO DI TRAINO	ACCIAIO INOX AISI 304	JOINT	AISI 304
5	LINGUETTA	ACCIAIO INOX AISI 304	KEY	AISI 304
6	ALBERO POMPA	ACCIAIO INOX AISI 304	PUMP SHAFT	AISI 304
7	ANELLO USURA	GOMMA NBR	USURY RING	NBR
8	CONO	ACCIAIO INOX AISI 304	CONE	AISI 304
9	GHIERA ESAGONALE	ACCIAIO INOX AISI 304	HEXAGONAL RING	AISI 304
10	BRONZINA	GOMMA NBR	BEARING BUSH	NBR
11	DIFFUSORE	ACCIAIO INOX AISI 304	DIFFUSER	AISI 304
12	GIRANTE	ACCIAIO INOX AISI 202	IMPELLER	AISI 202
13	CONTROSOSPENSIONE	PTFE+25% CARBONE	COUNTERTHRUST	PTFE+25% CARBON
14	GUARNIZIONE FARFALLA	GOMMA NBR	GASKET VALVE	NBR
15	FARFALLA	ACCIAIO INOX AISI 304	CAP VALVE	AISI 304
16	MANDATA	ACCIAIO INOX AISI 304	DELIVERY BOWL	AISI 304
17	GRANO ANTISVITAMENTO	ACCIAIO INOX AISI 304	SCREWS FOR LOCKING	AISI 304
18	GRANO BLOCCA DIFFUSORE	ACCIAIO INOX AISI 304	SCREWS FOR LOCKING DIFFUSER	AISI 304
19	STAFFETTA INFERIORE	ACCIAIO INOX AISI 304	LOWER FLANGE	AISI 304
20	VITI PER STAFFETTA INFERIORE	ACCIAIO INOX AISI 304	SCREW FOR LOWER FLANGE	AISI 304
21	COPRICAVO	ACCIAIO INOX AISI 304	COVER CABLE	AISI 304
22	STAFFETTA SUPERIORE	ACCIAIO INOX AISI 304	UPPER FLANGE	AISI 304
23	VITI STAFFETTA SUPERIORE	ACCIAIO INOX AISI 304	SCREW FOR UPPER FLANGE	AISI 304
24	O-RING	GOMMA NBR	O-RING	NBR

N. CODE	DESCRIPTION (Français)	MATÉRIEL (Français)	DESCRIPCIÓN (español)	MATERIAL (español)
1	CAGE D'ASPIRATION	ACIER INOXYDABLE AISI 304	CUERPO DE ASPIRACION	ACERO INOXYDABLE AISI 304
2	CREPINE	ACIER INOXYDABLE AISI 304	REJILLA	ACERO INOXYDABLE AISI 304
3	VIS POUR CREPINE	ACIER INOXYDABLE AISI 304	TORNILLOS REJILLA	ACERO INOXYDABLE AISI 304
4	JOINT	ACIER INOXYDABLE AISI 304	ACOPLAMIENTO	ACERO INOXYDABLE AISI 304
5	KEY	ACIER INOXYDABLE AISI 304	KEY	ACERO INOXYDABLE AISI 304
6	ABRE POMPE	ACIER INOXYDABLE AISI 304	EJE DE BOMBA	ACERO INOXYDABLE AISI 304
7	BAGUE D'USURE	CAOUTCHOUC	ANILLO DE DESGASTE	GOMA
8	CONE	ACIER INOXYDABLE AISI 304	CONO	ACERO INOXYDABLE AISI 304
9	BAGUE HEXAGONE	ACIER INOXYDABLE AISI 304	ANILLO HEXAGONAL	ACERO INOXYDABLE AISI 304
10	COUSSINET	CAOUTCHOUC	COJINETE	GOMA
11	DIFFUSEUR	ACIER INOXYDABLE AISI 304	DIFUSOR	ACERO INOXYDABLE AISI 304
12	ROUE	ACIER INOXYDABLE AISI 202	IMPULSOR	ACERO INOXYDABLE AISI 202
13	CONTRESUSPENSION	PTFE+25% CHARBON	CONTRA-SUSPENSION	PTFE + 25% GRAPHITE
14	GASKET VALVE	CAOUTCHOUC	JUNTA DE VALVULA	GOMA
15	PLAT	ACIER INOXYDABLE AISI 304	VALVULA	ACERO INOXYDABLE AISI 304
16	REFOULEMENT	ACIER INOXYDABLE AISI 304	CUERPO DE IMPULSION	ACERO INOXYDABLE AISI 304
17	VIS DE BLOCAGE	ACIER INOXYDABLE AISI 304	TORNILLO DE BLOQUEO	ACERO INOXYDABLE AISI 304
18	VIS DE BLOCAGE DIFFUSEUR	ACIER INOXYDABLE AISI 304	TORNILLO DE BLOQUEO DIFUSOR	ACERO INOXYDABLE AISI 304
19	BRIDE INFERIEURE	ACIER INOXYDABLE AISI 304	GRAPA INFERIOR	ACERO INOXYDABLE AISI 304
20	VIS POUR BRIDE INFERIEURE	ACIER INOXYDABLE AISI 304	TORNILLO PARA GRAPA INFERIOR	ACERO INOXYDABLE AISI 304
21	PROTECTOR CABLE	ACIER INOXYDABLE AISI 304	PARACABLE	ACERO INOXYDABLE AISI 304
22	BRIDE SUPERIEURE	ACIER INOXYDABLE AISI 304	GRAPA SUPERIOR	ACERO INOXYDABLE AISI 304
23	VIS POUR BRIDE SUPERIEURE	ACIER INOXYDABLE AISI 304	TORNILLO PARA GRAPA SUPERIOR	ACERO INOXYDABLE AISI 304
24	O-RING	CAOUTCHOUC	ANILLO TORICO	GOMA

PANELLI®

italian excellence since 1906

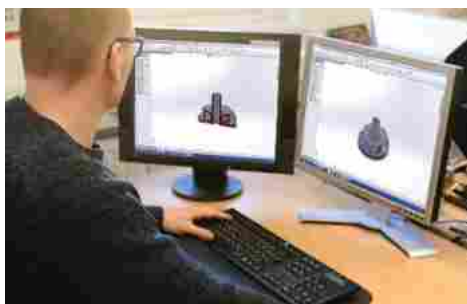

Panelli s.r.l.

Sede legale: 37047 San Bonifacio (VR) ITALY - Via E. Fermi, 7

Unità produttiva: 15122 (Alessandria) ITALY

Via Rana , 63/65 – Z.I D5 - Spinetta Marengo

Phone : + 39 0131 619506 - Fax : + 39 0131 619017

Email : info@panellipumps.it - www.panellipumps.it

Società soggetta a direzione e coordinamento di

PEDROLLO GROUP s.r.l.

